

BREAKFAST TOP

ISTRUZIONI DI MONTAGGIO ASSEMBLY INSTRUCTIONS

MODELLI:
MODELS:

- 411/78.1252.22 Breakfast top 1200 mm, apertura 900 mm
Breakfast top 1200 mm, opening 900 mm
- 411/78.1253.22 Breakfast top 1800 mm, apertura 1200 mm
Breakfast top 1800 mm, opening 1200 mm
- 411/78.1254.22 Breakfast top 2400 mm, apertura 1500 mm
Breakfast top 2400 mm, opening 1500 mm
- 411/78.1255.22 Breakfast top 3000 mm, apertura 1500 mm
Breakfast top 3000 mm, opening 1500 mm

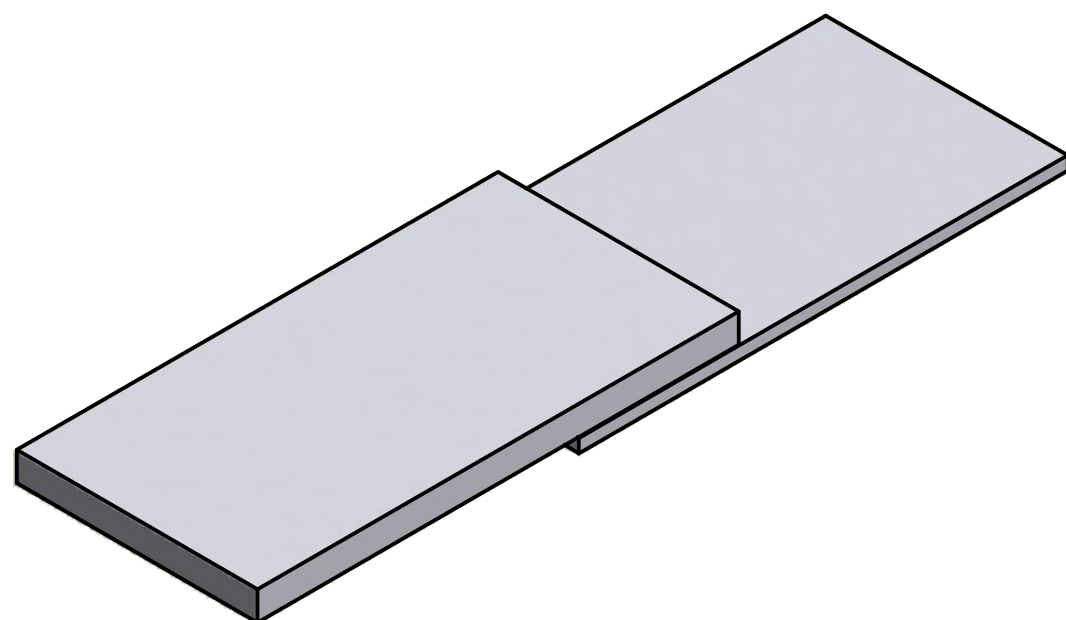

CONTENUTO DELLA CONFEZIONE INCLUDED IN THE PACKAGING

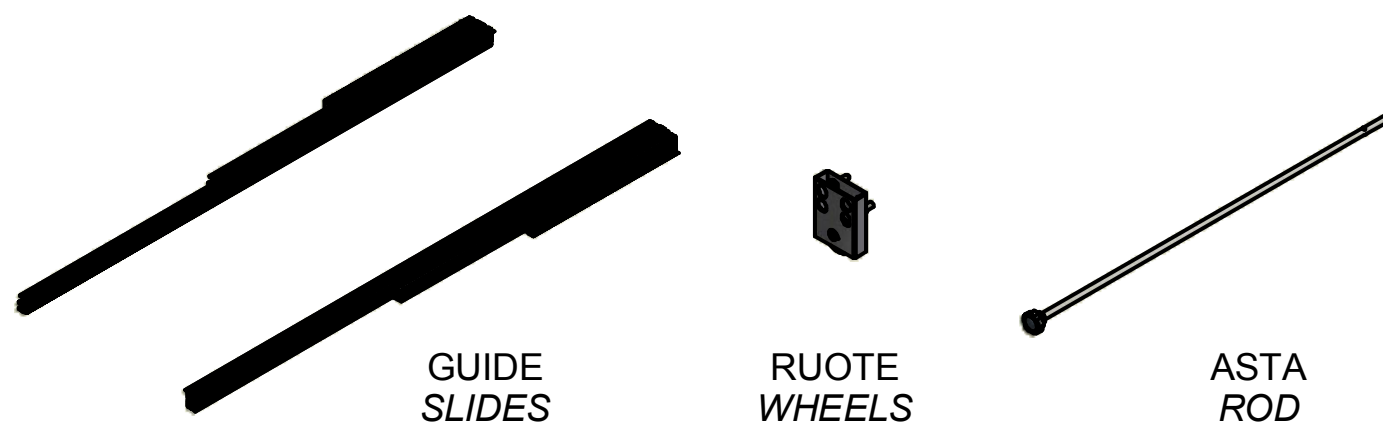















GUIDE
SLIDES

RUOTE
WHEELS

ASTA
ROD

SACCHETTO ACCESSORI - ACCESSORIES

-  A. Chiave esa. n.5 - *n.5 Allen key*
-  B. Chiave esa. n.4 - *n.4 Allen key*
-  C. Chiave esa. n.3 - *n.3 Allen key*
-  D. Rondella Ø12x1.35 - *Washer Ø12x1.35 (x4)*
-  E. Vite truciolare 3.5x23 - *3.5x23 chipboard screw (x2)*
-  F. Vite TPS M5x16 - *M5x16 tapered screw (x1)*
-  G. Vite TCCE M6x16 - *Socketed head cap screw M6x16 (x8)*
-  H. Vite TCBCE M6x22 ISO 7380 - *M6x22 ISO 7380 screw (x4)*
-  I. Vite TPS M6x60 - *M6x60 tapered screw (x16)*
-  J. Bussola M6 12x8 mm - *Bush M6 12x8 mm (x16)*
-  K. Blocco - *Block (x1)*
-  L. Perno Ø10x23 - *Pin Ø10x23 (x1)*
-  M. Rondella Ø16 - *Washer Ø16 (x2)*
-  N. Dado M8 - *Nut M8 (x1)*

DIMENSIONI DI MASSIMA

GENERAL DIMENSIONS

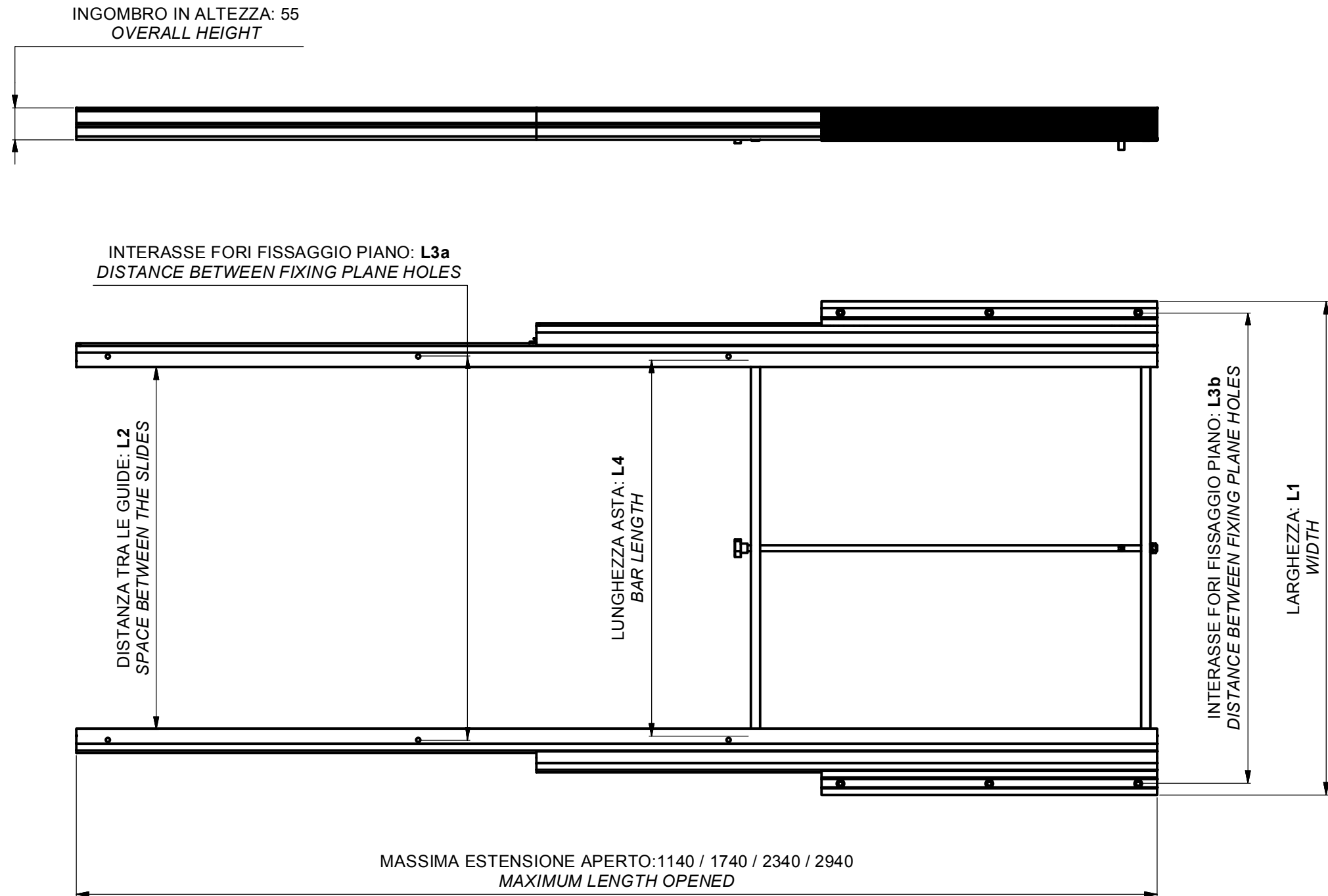

MODELLO - MODEL	MODULO - MODULE	L1 (mm)	L2 (mm)	L3a (mm)	L3b (mm)	L4 (mm)
411/78.1252.22	1200	794.5	518.5	555	758	540.5
411/78.1253.22	1800	794.5	582.5	619	758	604.5
411/78.1254.22	2400	794.5	582.5	619	758	604.5
411/78.1255.22	3000	794.5	582.5	619	758	604.5

DIMENSIONI GENERALI MOBILE GENERAL CABINET DIMENSIONS

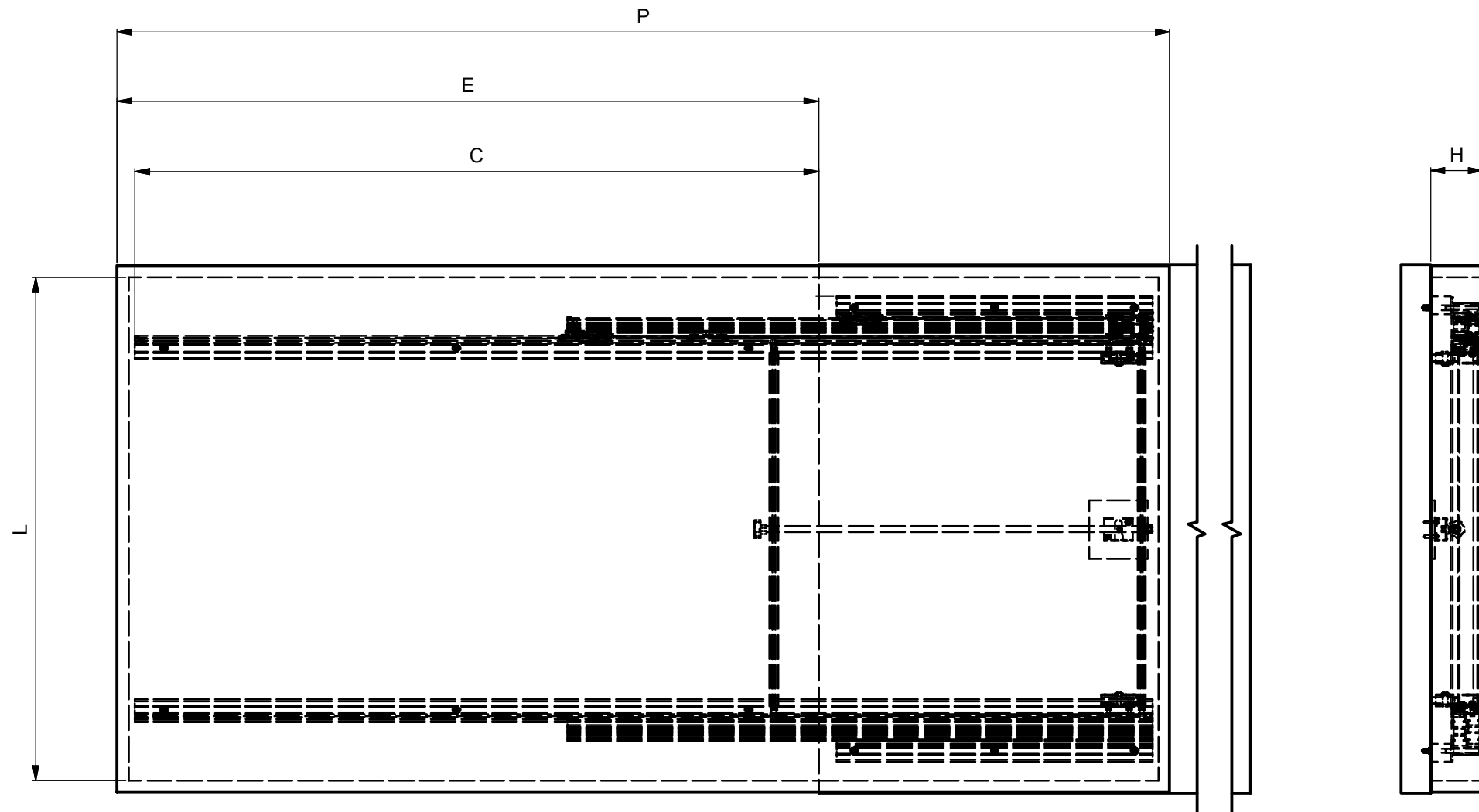

DIMENSIONE - DIMENSION	SIMBOLO - SYMBOL	
LUCE VERTICALE - VERTICAL FREE SPACE	H	MIN: 65 mm
LUNGHEZZA - LENGTH	P	MIN: 900 mm
LARGHEZZA INTERNA MODULO - CABINET INTERNAL WIDTH	L	MIN: 800 mm
APERTURA PIANI - OPENING PLANE	E	MIN: 900 mm MAX: 1500 mm
APERTURA MECCANISMO - OPENING MECHANISM	C	MIN: 900

POSIZIONE FORI FISSAGGIO MECCANISMO HOLES FOR MECHANISM POSITION

FORI - HOLES: $\varnothing 8 \nabla 13$

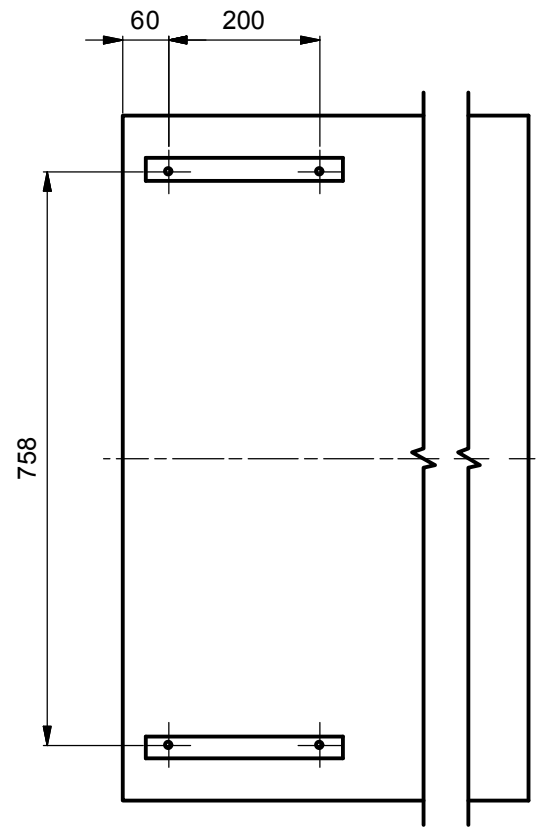

411/78.1252.22

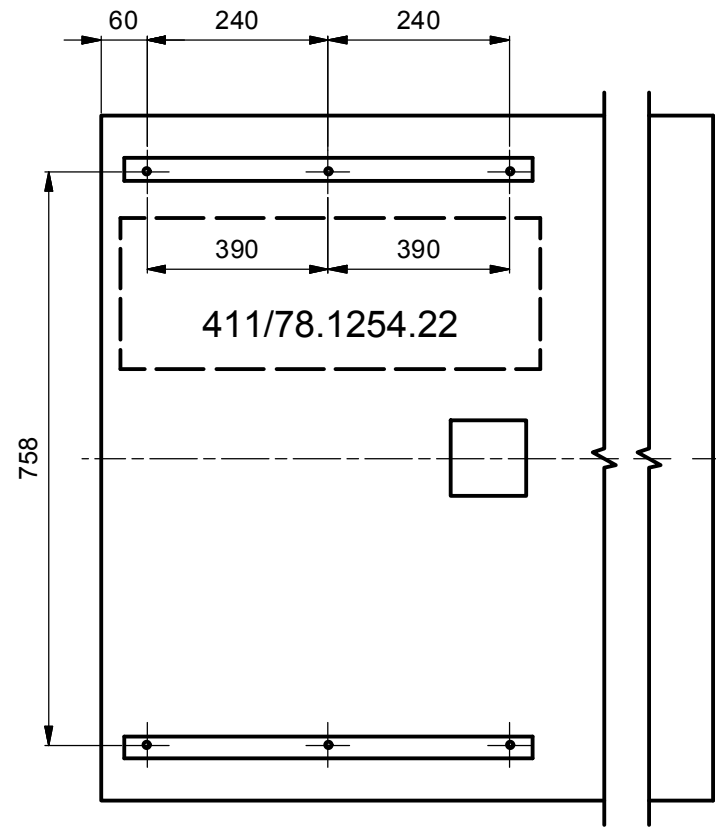

411/78.1253.22

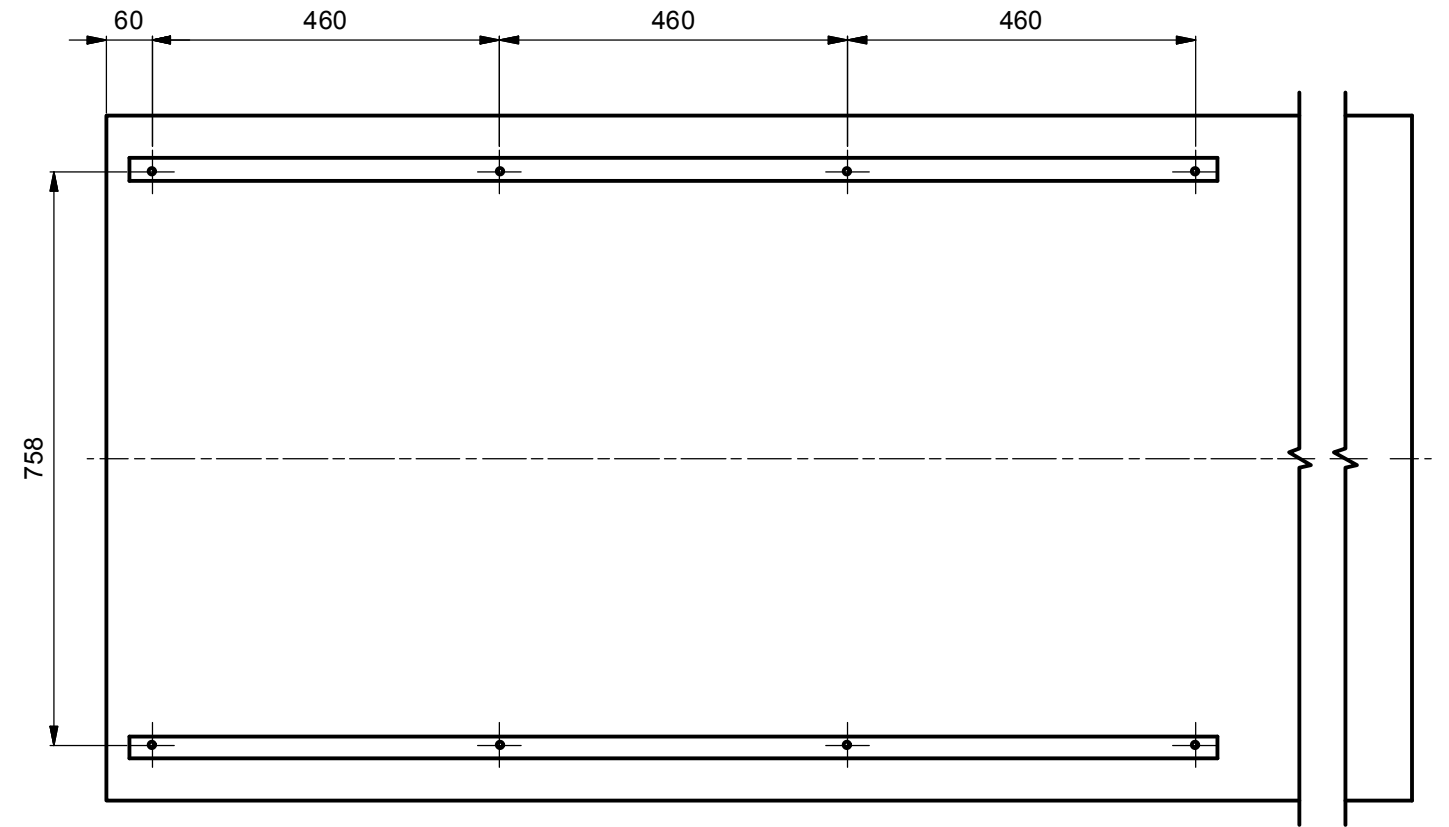

411/78.1255.22

SACCHETTO ACCESSORI - ACCESSORIES



J. Bussola in ottone M6 12x8 mm - M6 12x8 mm brass bush

DIMENSIONE PIANO

PLANE SIZE

FORI - HOLES: Ø8 ∇13

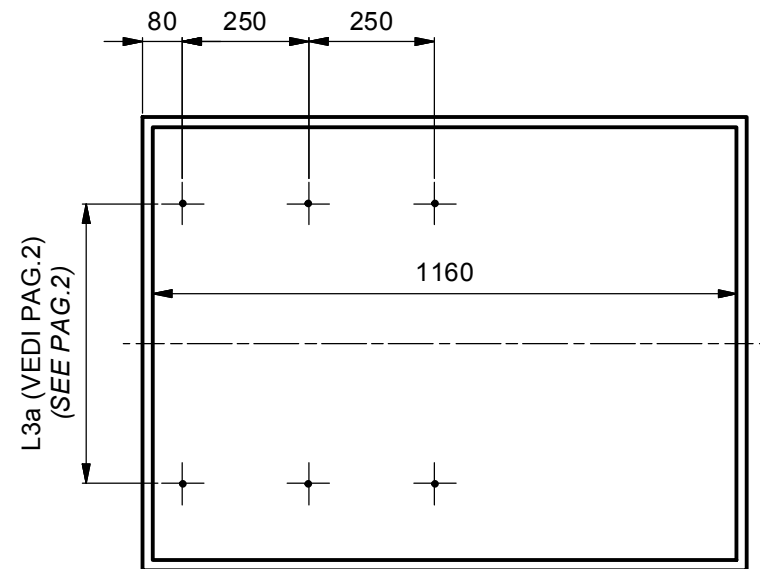

411/78.1252.22

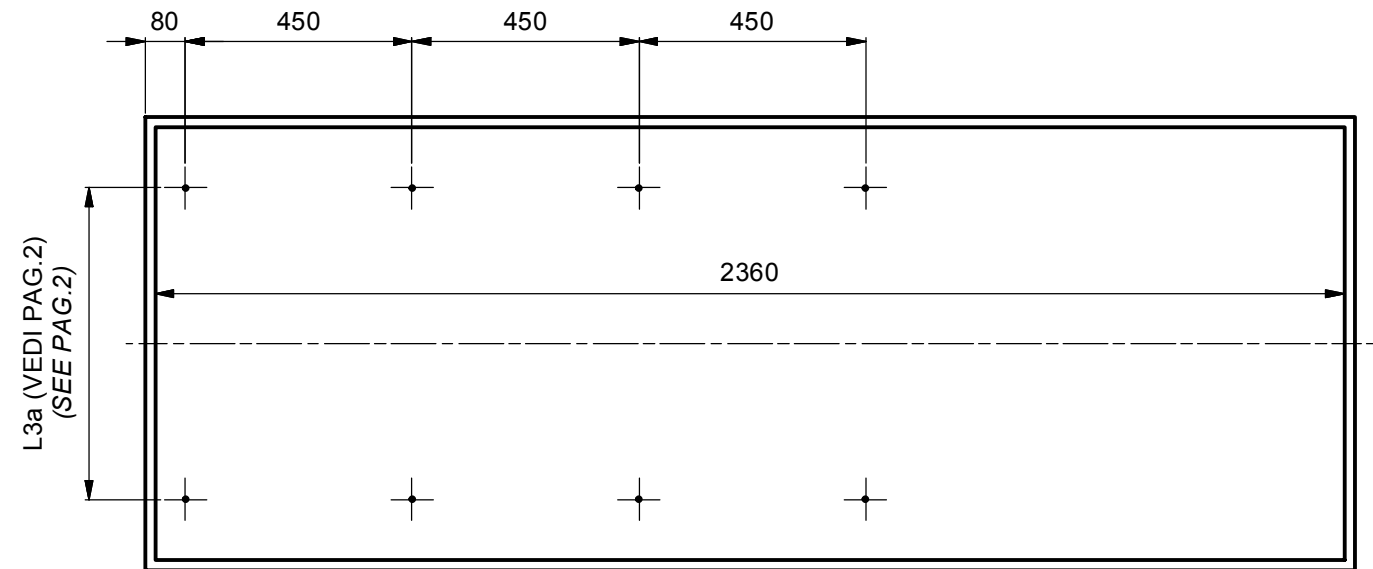

411/78.1253.22

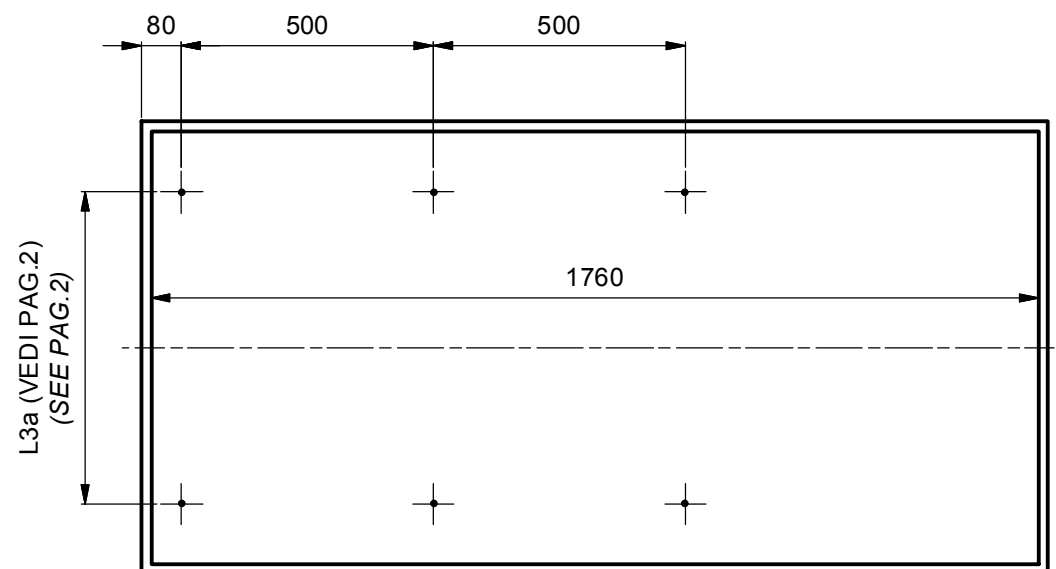

411/78.1254.22

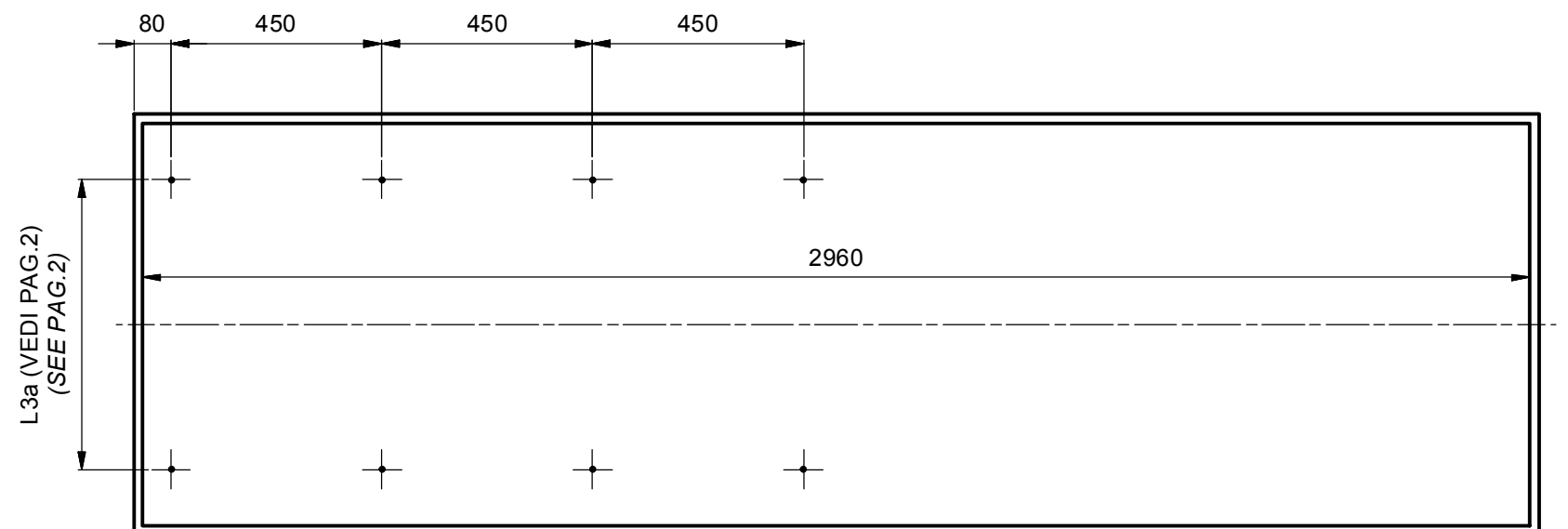

411/78.1255.22

SACCHETTO ACCESSORI - ACCESSORIES





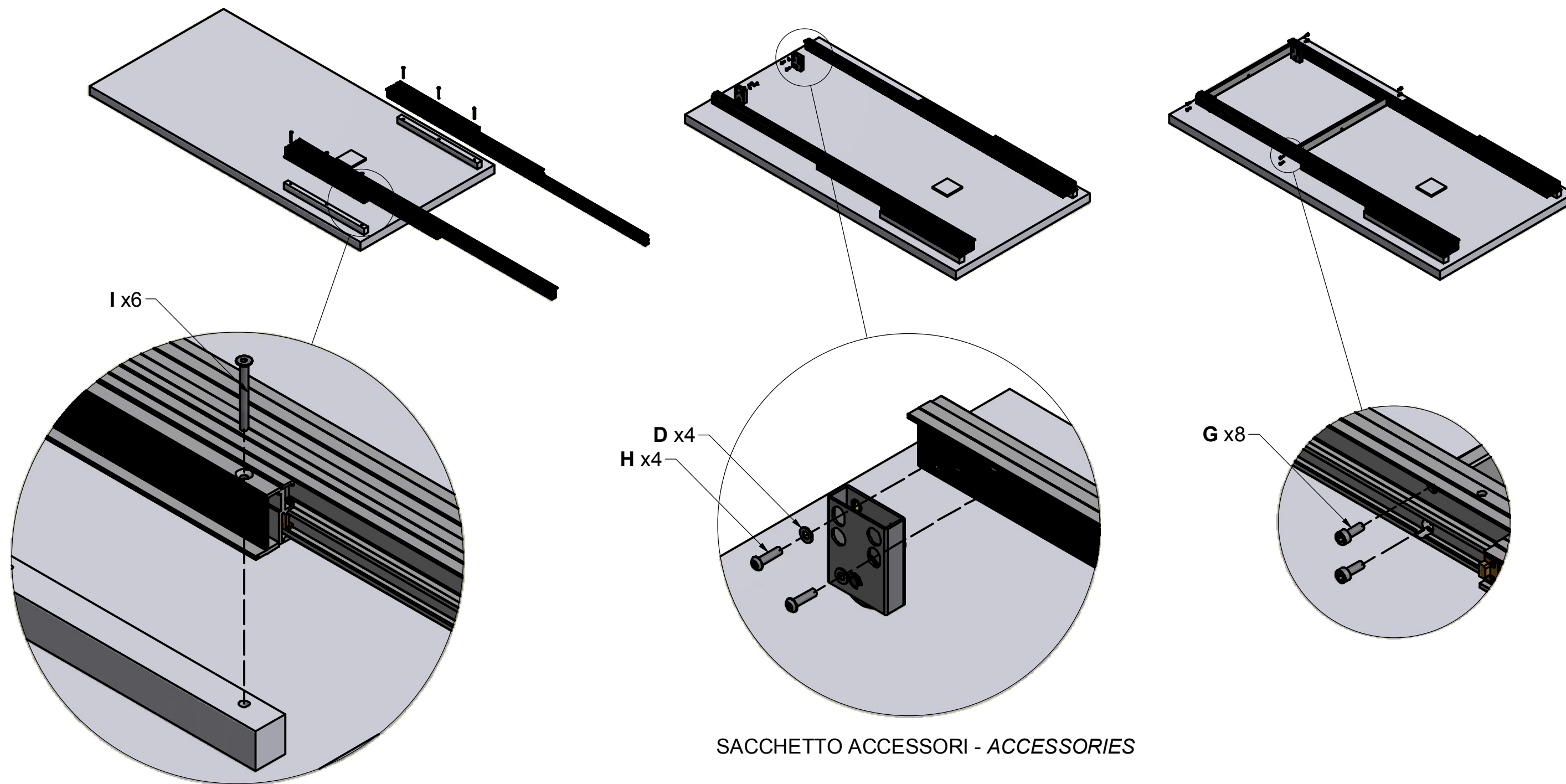

J. Bussola in ottone M6 12x8 mm - M6 12x8 mm brass bush

MONTAGGIO DEL MECCANISMO SUL MOBILE MOUNTING OF THE MECHANISM ON THE CABINET



SACCHETTO ACCESSORI - ACCESSORIES

-  D. Rondella Ø12x1.35 - Washer Ø12x1.35 (x4)
-  G. Vite TCCE M6x16 - Socked head cap screw M6x16 (x8)
-  H. Vite TCBCE M6x22 ISO 7380 - M6x22 ISO 7380 screw (x4)
-  I. Vite TPS M6x60 - M6x60 tapered screw (x6)

MONTAGGIO DEL MECCANISMO SUL MOBILE

MOUNTING OF THE MECHANISM ON THE CABINET

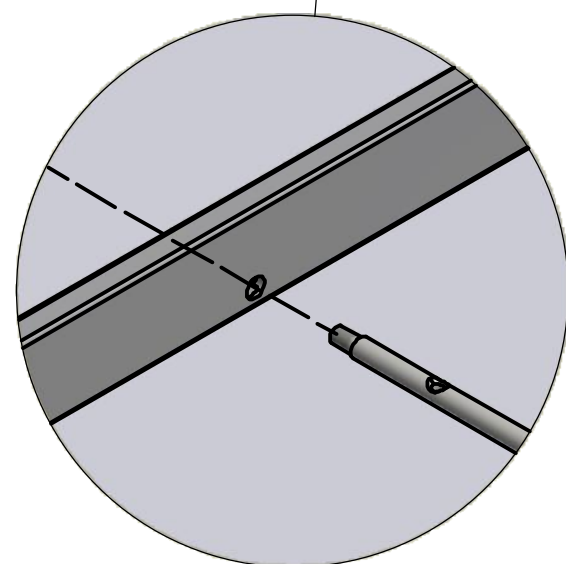
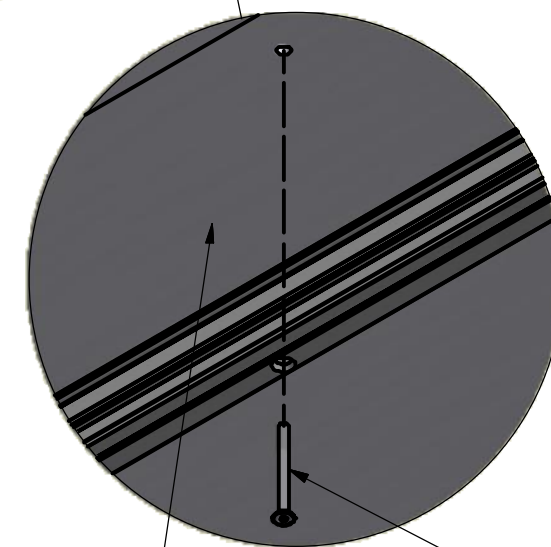
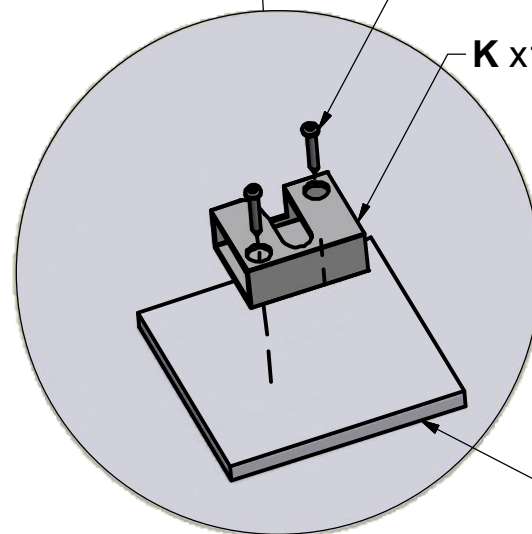
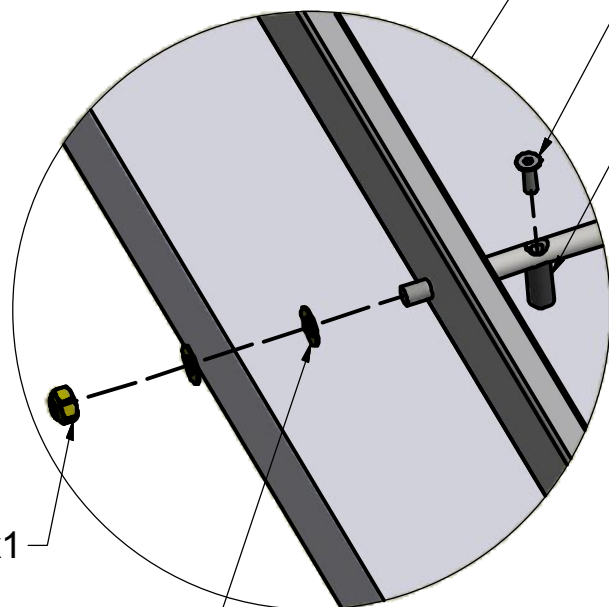
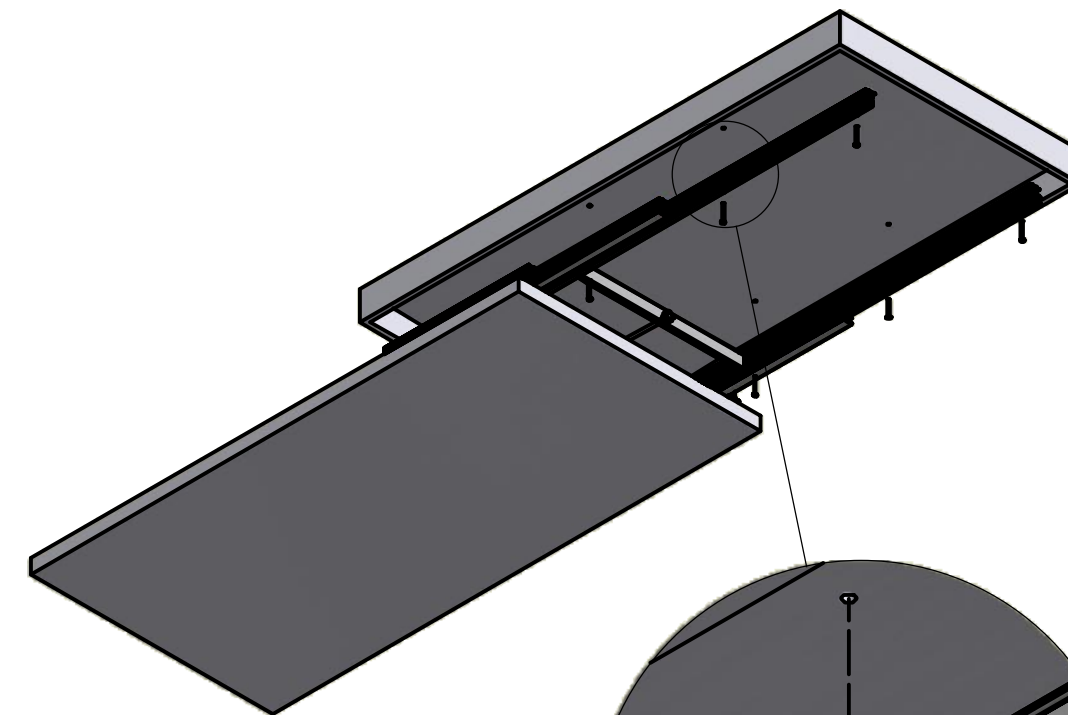
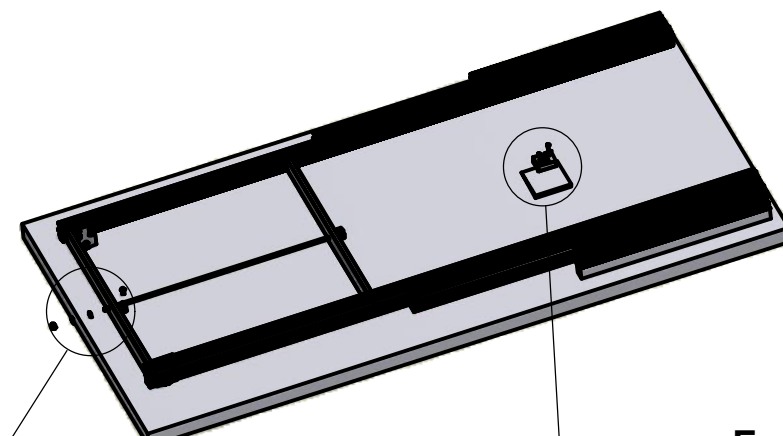
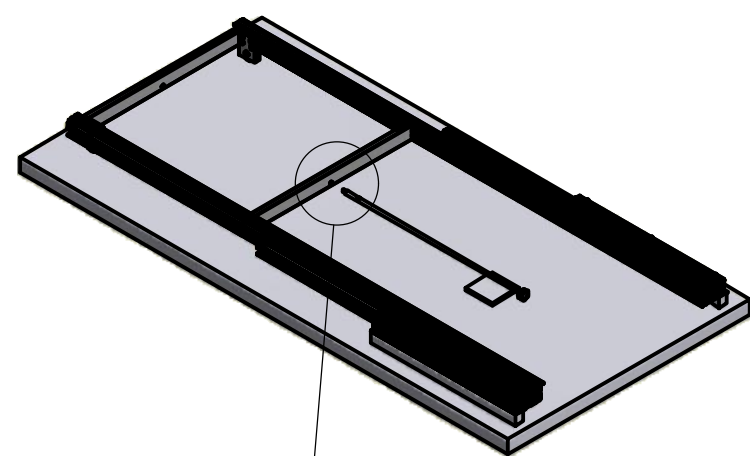

F x1

L x1

E x2

K x1

N x1

M x2

I x6

SACCHETTO ACCESSORI - ACCESSORIES

SPESSORE BLOCCO:
BLOCK THICKNESS:
MAX: 8 mm
MIN: 5 mm

SPESSORE PIANO:
PLANE THICKNESS:
2 mm



E. Vite truciolare 3.5x23 - 3.5x23 chipboard screw (x2)



F. Vite TPS M5x16 - M5x16 tapered screw (x1)



I. Vite TPS M6x60 - M6x60 tapered screw (x16)



K. Blocco - Block (x1)



L. Perno Ø10x23 - Pin Ø10x23 (x1)



M. Rondella Ø16 - Washer Ø16 (x2)



N. Dado M8 - Nut M8 (x1)