

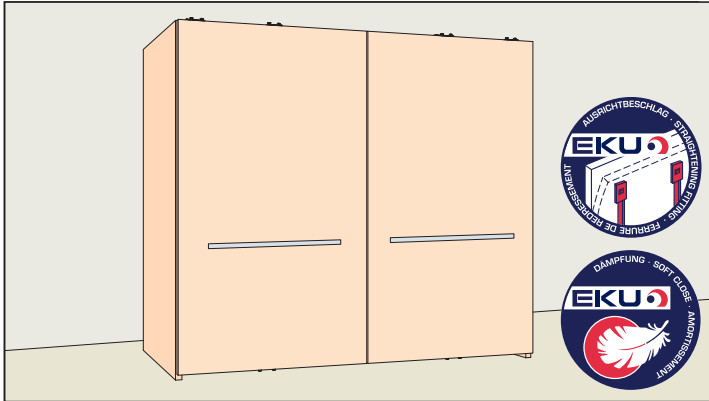

Video



Swiss Quality - tested in accordance with EN 15706



Set

| | | | | | |
|-----------------------------------|--|--|--|----|--|
| 2 Türen Doors Portes | | Typ M = KAM 1800-2199 mm No. 053.3320.072 | | | |
| | | | | 1x | |
| | | | | 1x | |
| | | | | 1x | |
| | | | | 1x | |
| | | | | 1x | |
| | | | | 1x | |
| | | | | 1x | |
| | | | | 1x | |
| | | | | 1x | |
| | | | | 1x | |
| | | | | 1x | |
| | | | | 1x | |
| | | | | 1x | |
| | | | | 1x | |
| | | | | 1x | |
| | | | | 1x | |
| | | | | 1x | |
| | | | | 1x | |
| | | | | 1x | |
| | | | | 1x | |
| | | | | 1x | |
| | | | | 1x | |
| | | | | 1x | |
| | | | | 1x | |
| | | | | 1x | |
| | | | | 1x | |
| | | | | 1x | |
| | | | | 1x | |
| | | | | 1x | |
| | | | | 1x | |
| | | | | 1x | |
| | | | | 1x | |
| | | | | 1x | |
| | | | | 1x | |
| | | | | 1x | |
| | | | | 1x | |
| | | | | 1x | |
| | | | | 1x | |
| | | | | 1x | |
| | | | | 1x | |
| | | | | 1x | |
| | | | | 1x | |
| | | | | 1x | |
| | | | | 1x | |
| | | | | 1x | |
| | | | | 1x | |
| | | | | 1x | |
| | | | | 1x | |
| | | | | 1x | |
| | | | | 1x | |

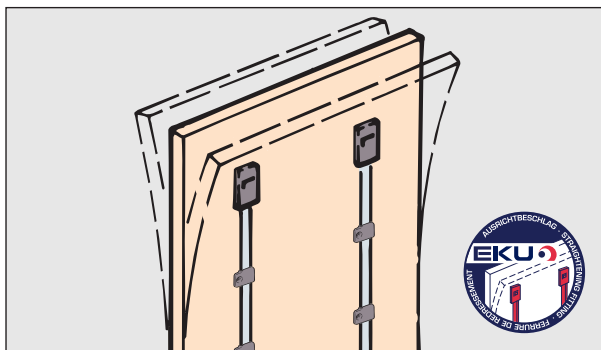

Endereamiento adecuado para estabilizar puertas correderas de hasta 2400 mm de alto. (no apto para madera solida)

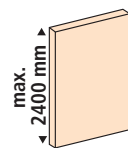
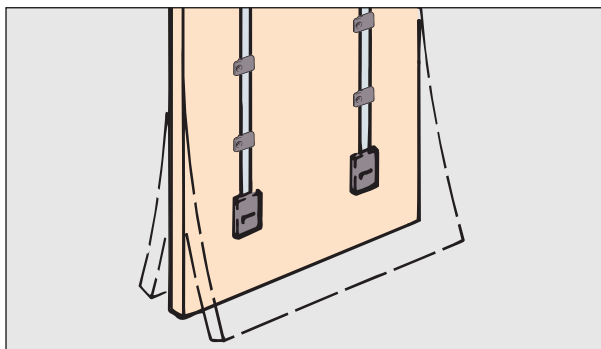

Set

| | | | |
|-------------------------------|-------------------------|-----|--|
| 1 Tür Door Porte | No. 056.3027.084 | | |
| | | 4x | |
| L = 1863 mm | | 10x | |
| | | | |

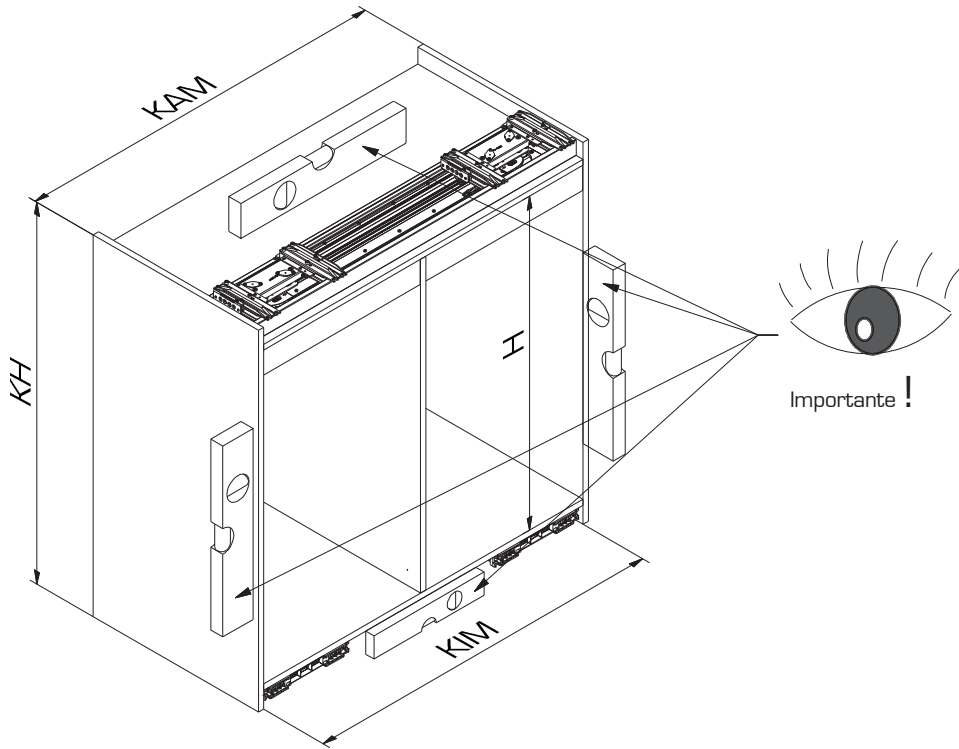

- Herramienta**
- ⊕ PZ: 2
 - ⬡ SW: 3 / 4 / 5
 - ⊗ TX: 25
 - ⊖ No.:
 - ⊗ SW: 8

A Set de rieles
 Typ M: Art.No. 053.3321.220 = 2200mm

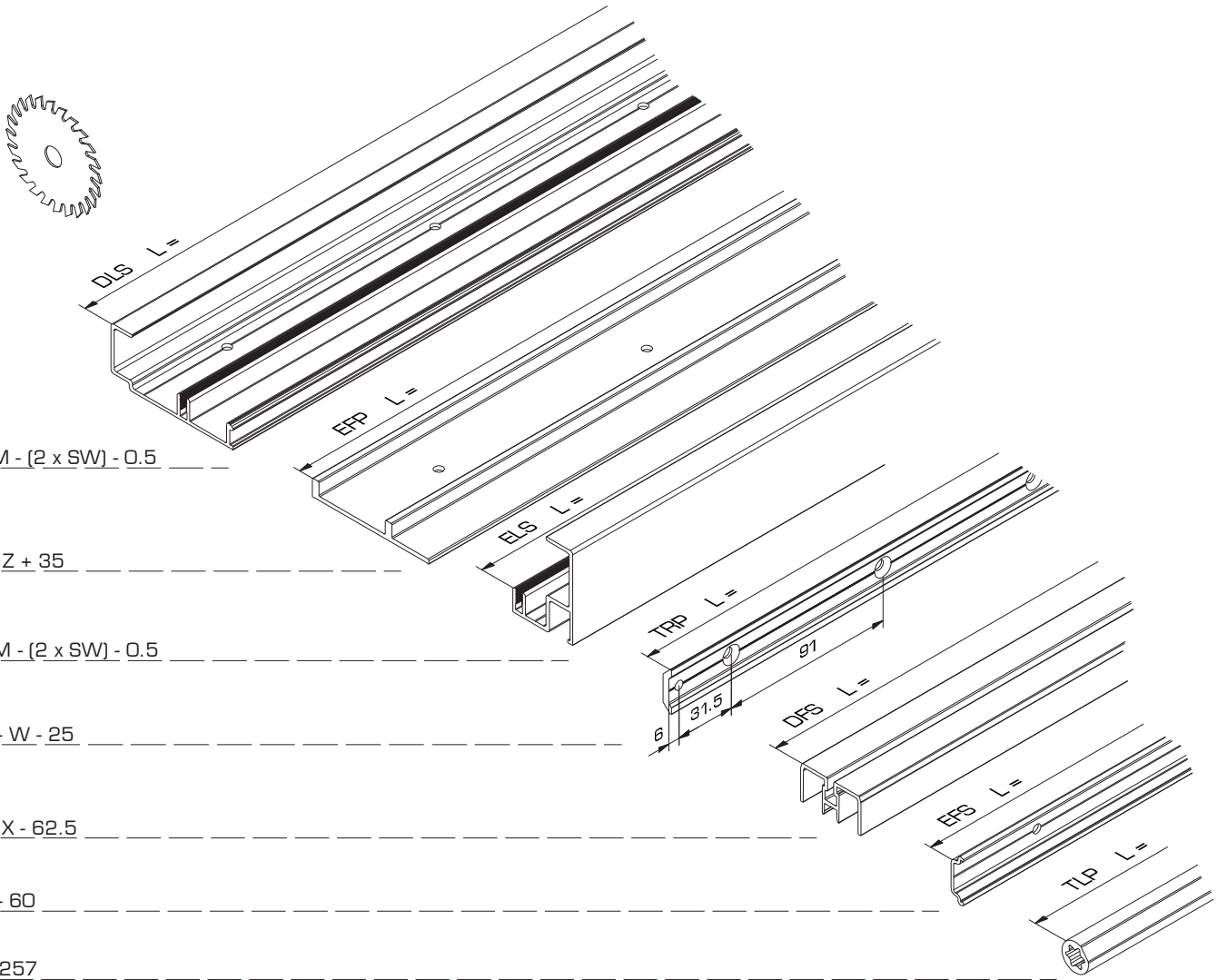

B Inferior

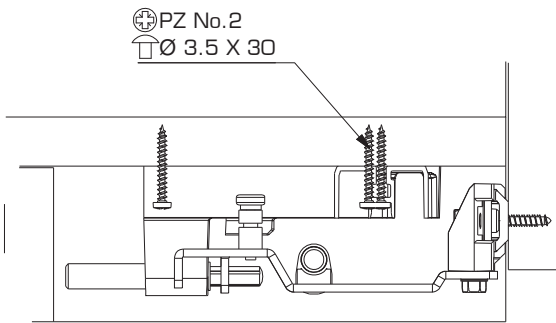
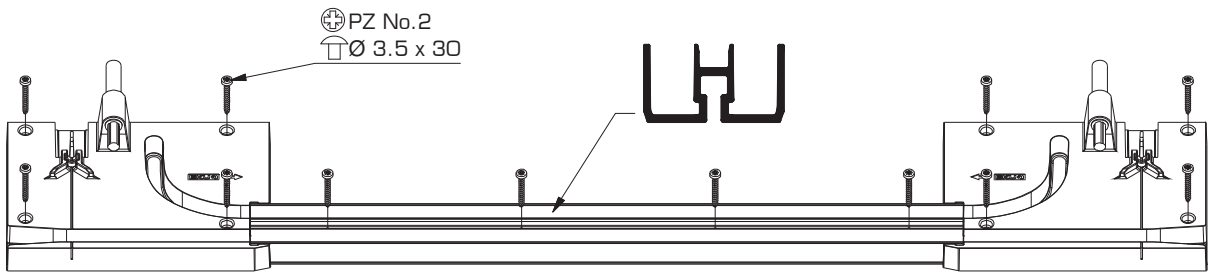
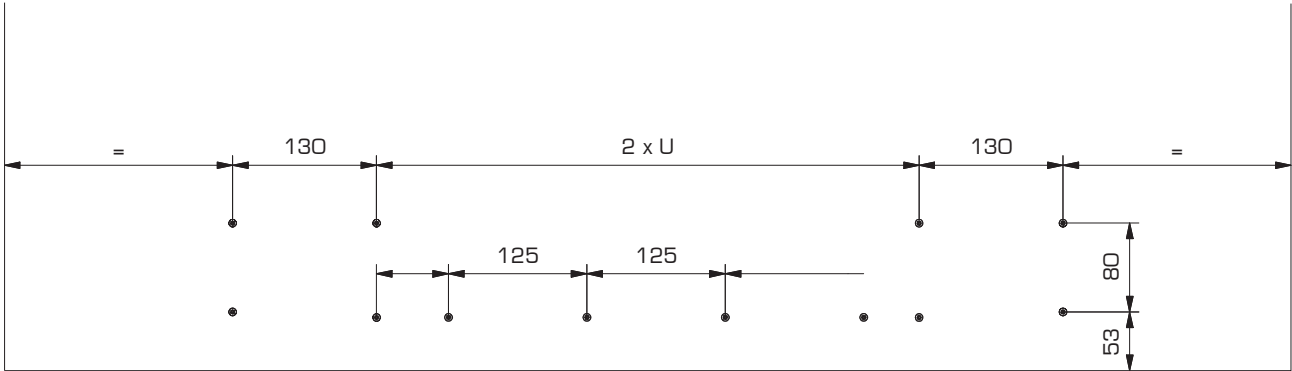

Variante

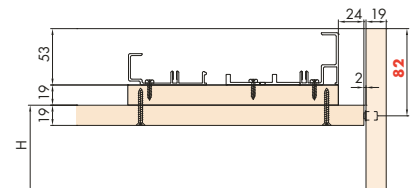

C Cubierta

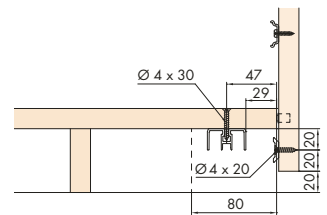
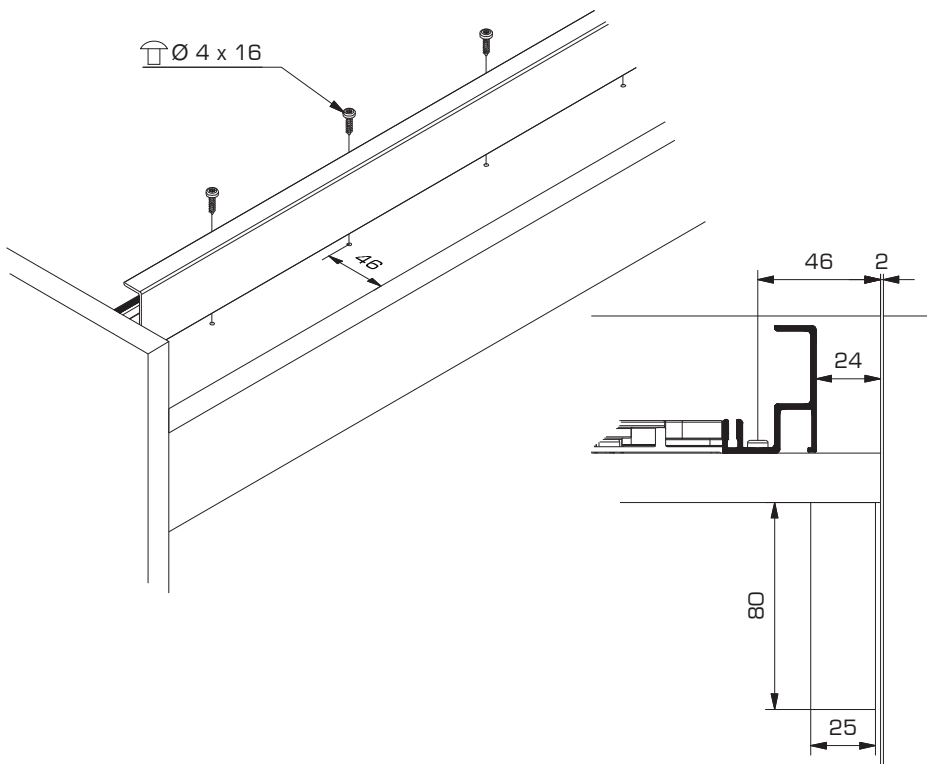

D

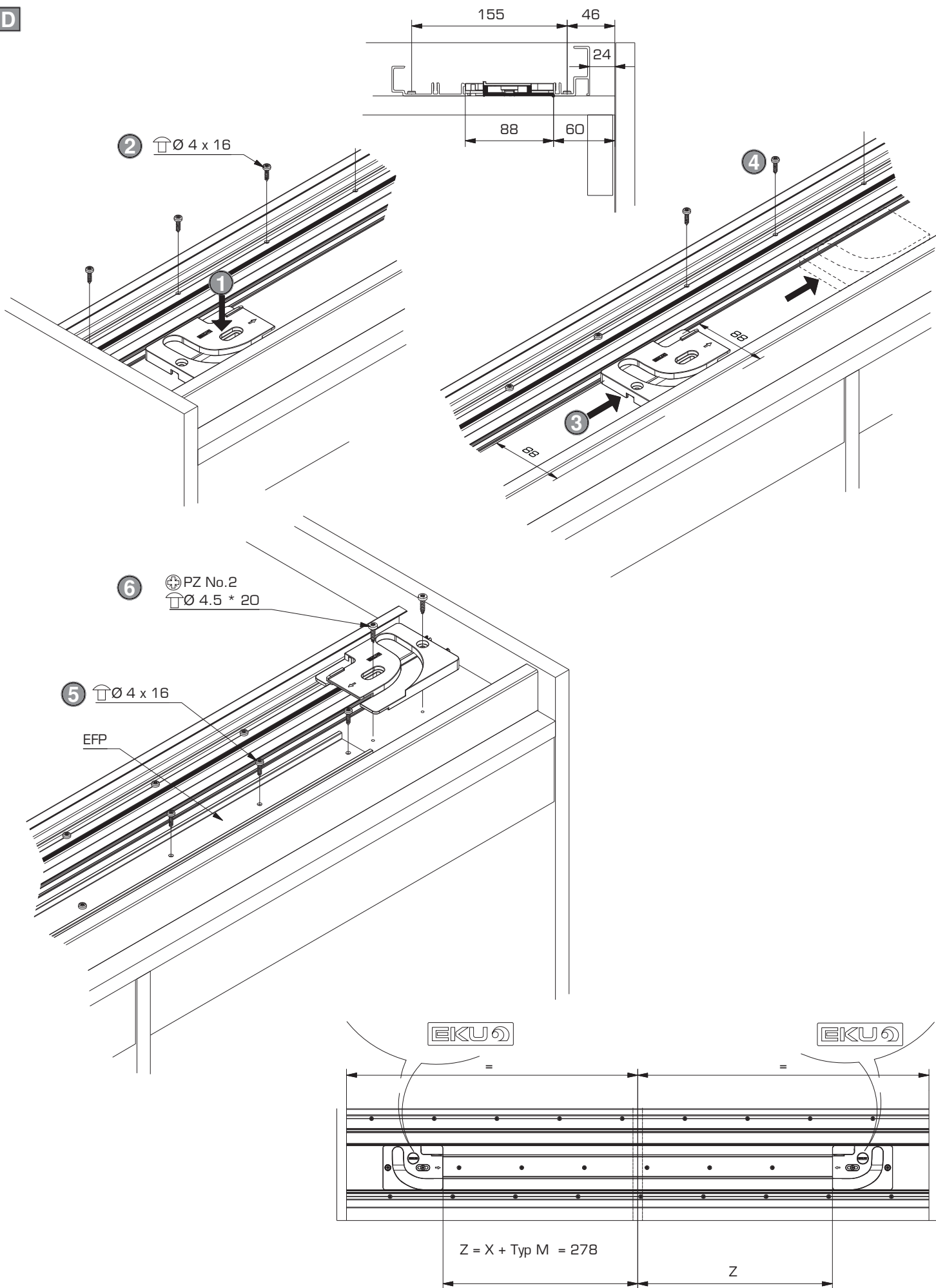

E Limpie los rieles!

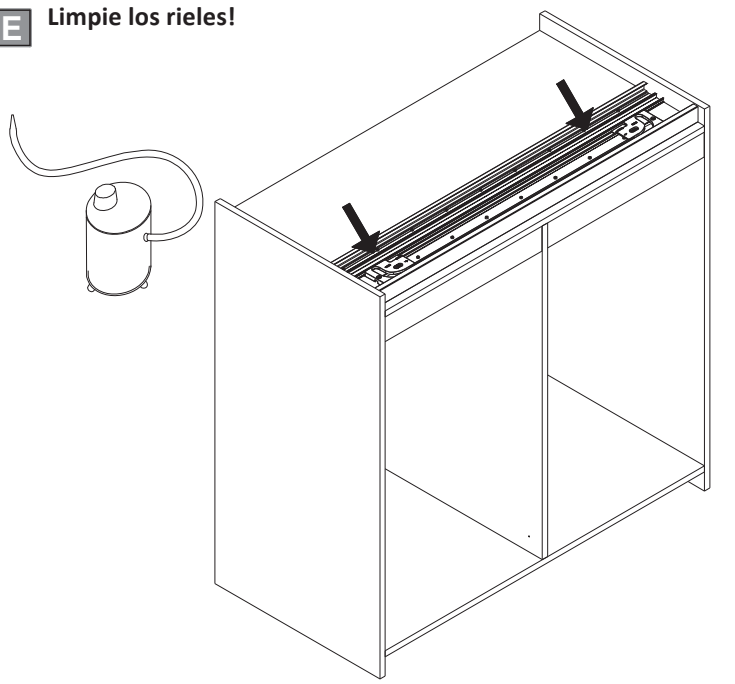

F

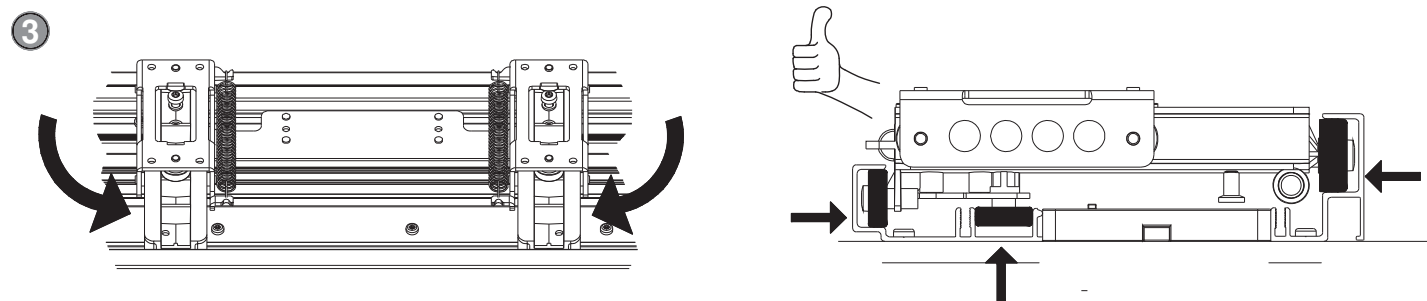
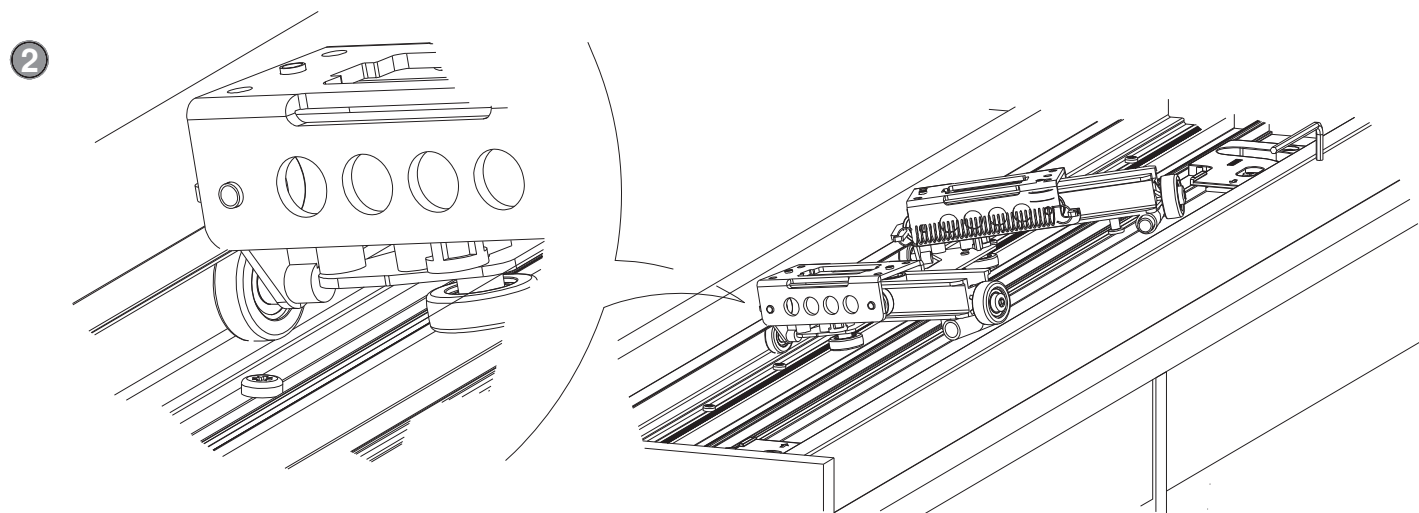
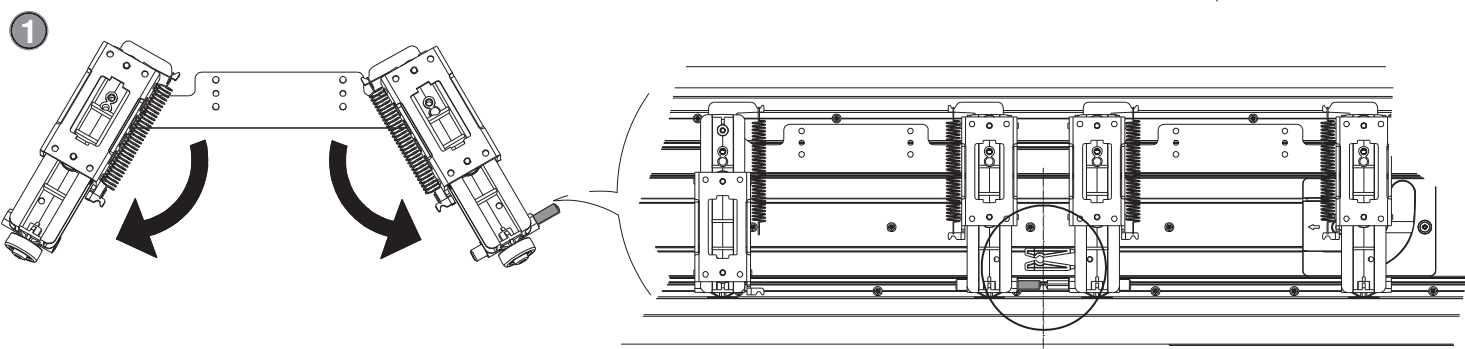
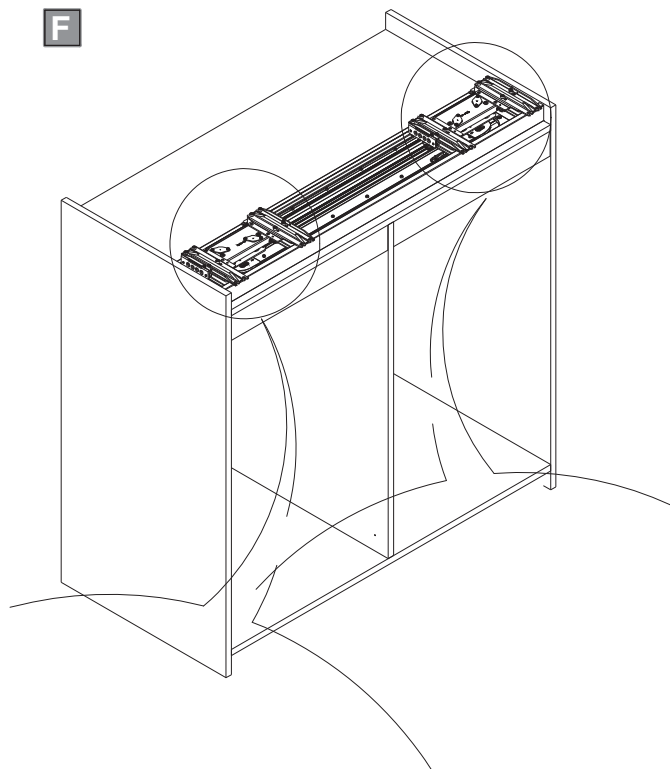

G

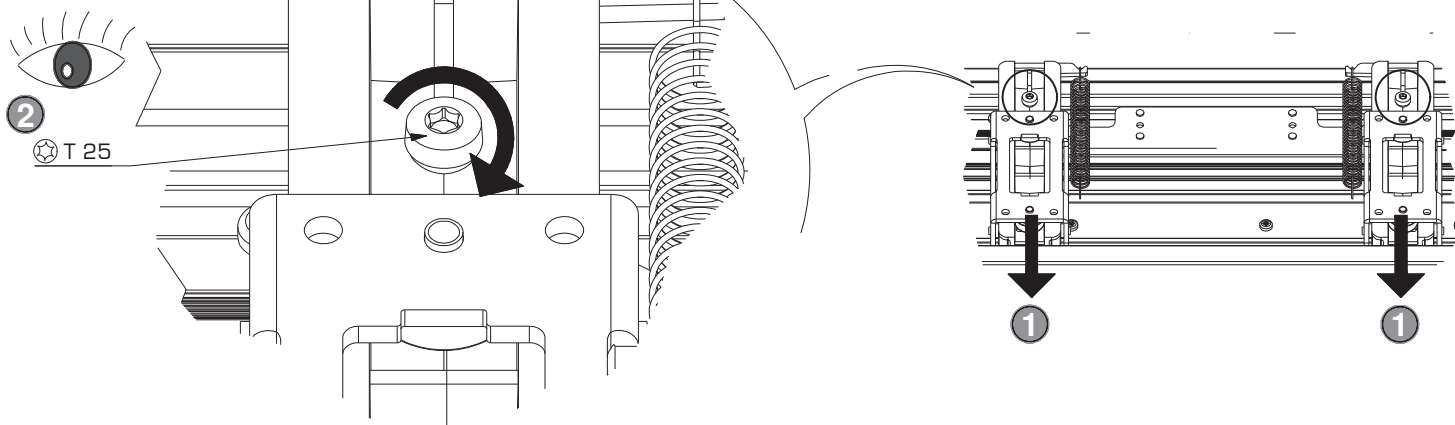

H

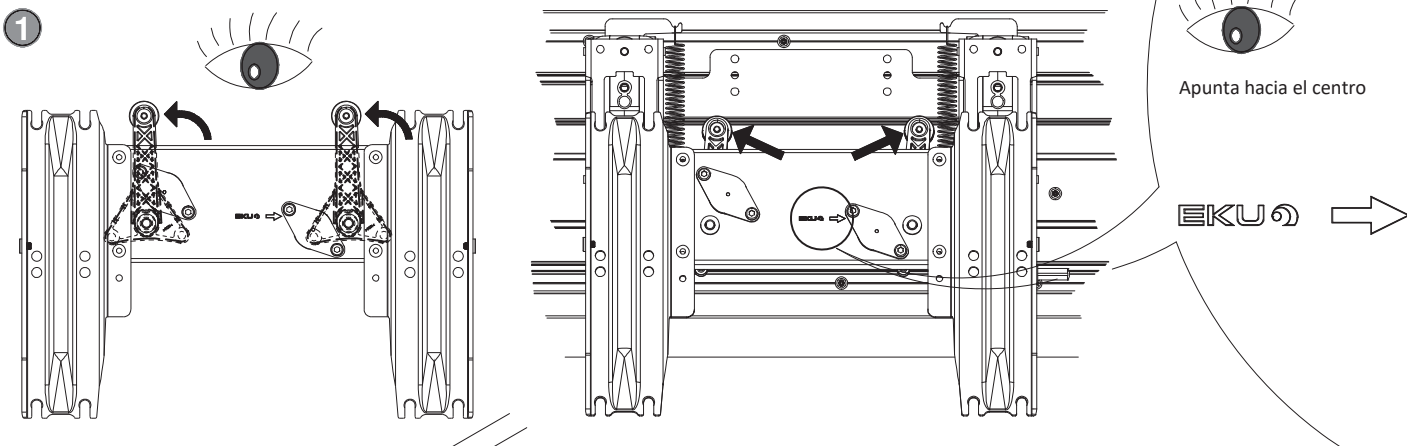

2

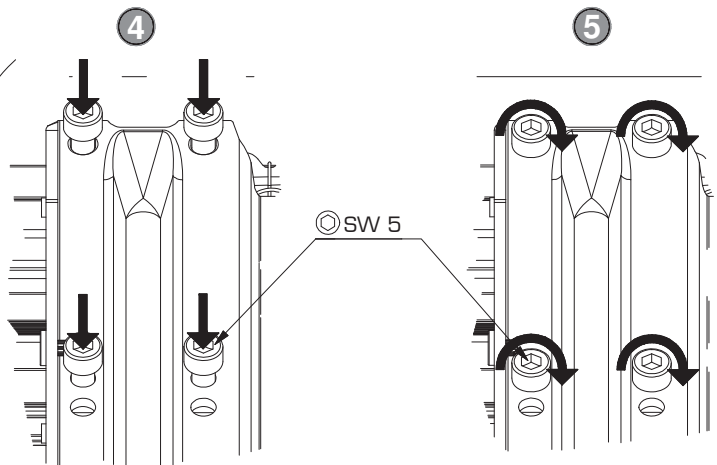
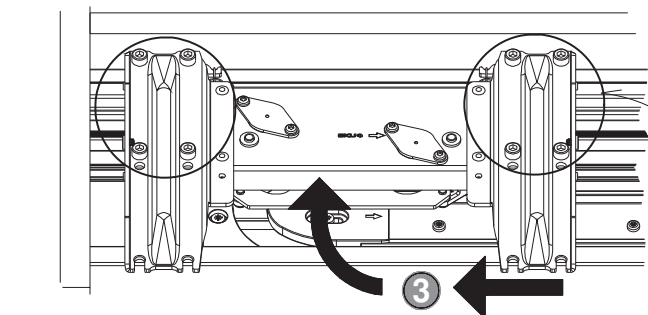
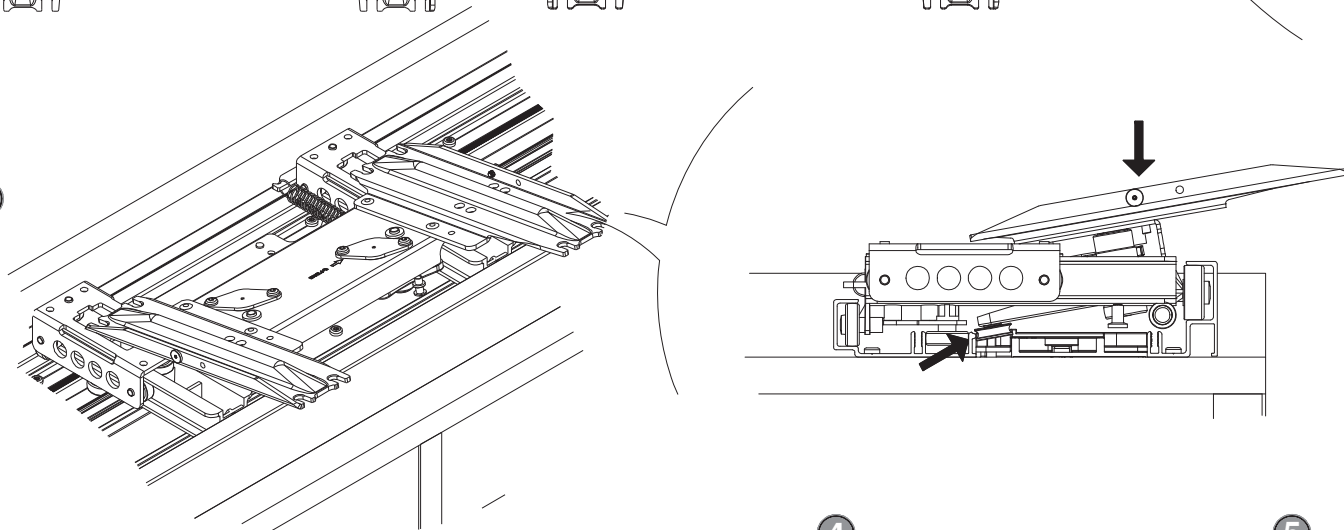

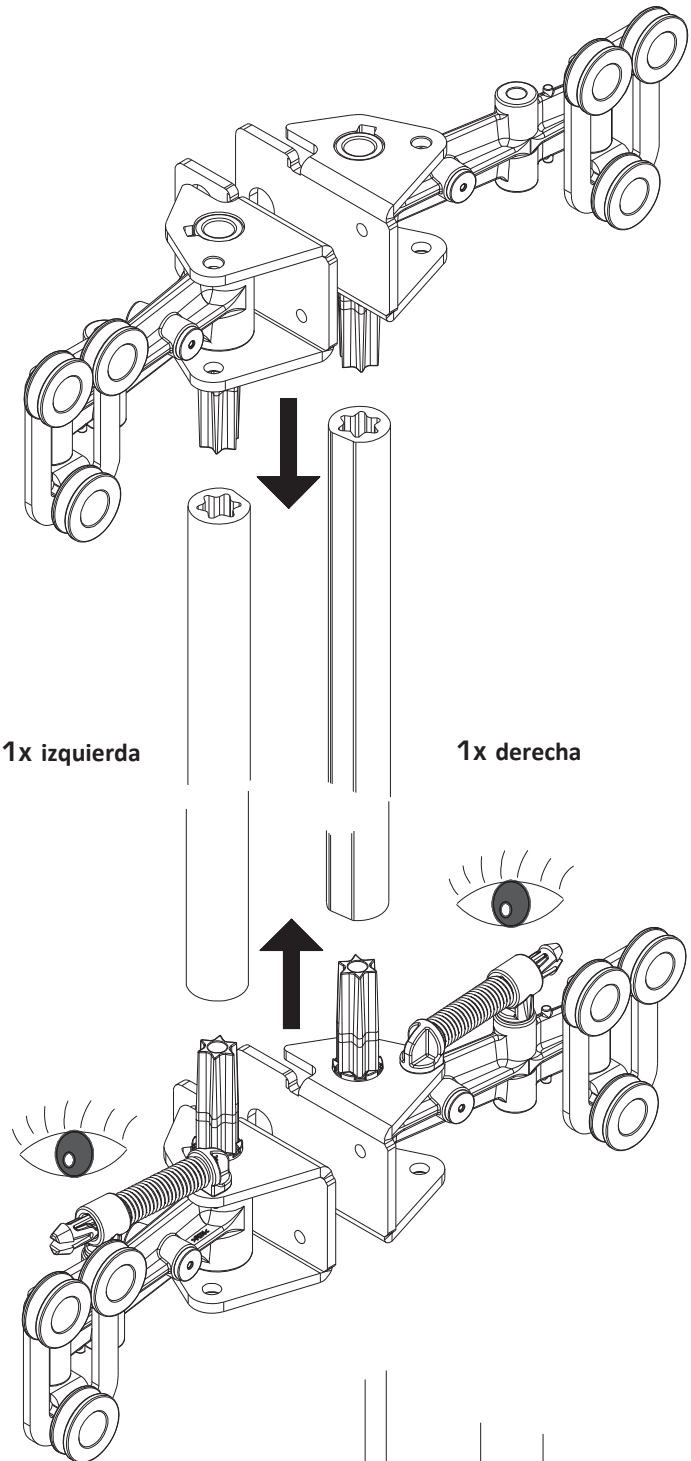

1x izquierda

1x derecha

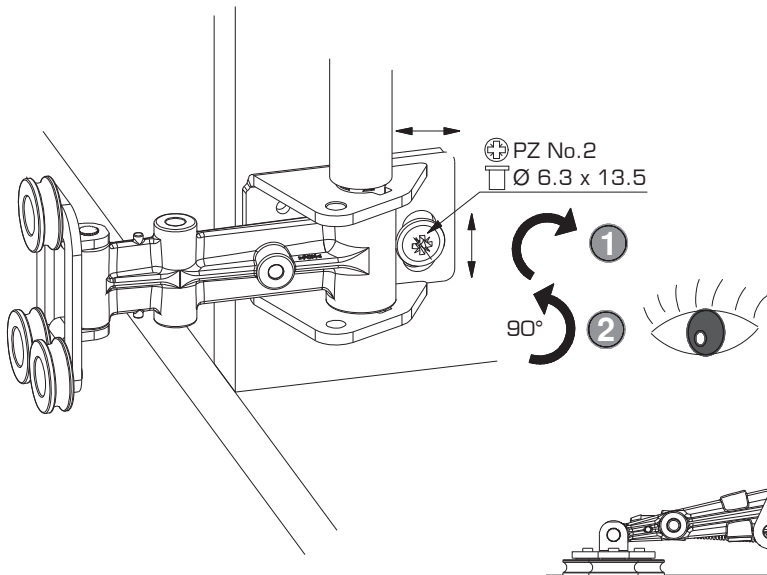
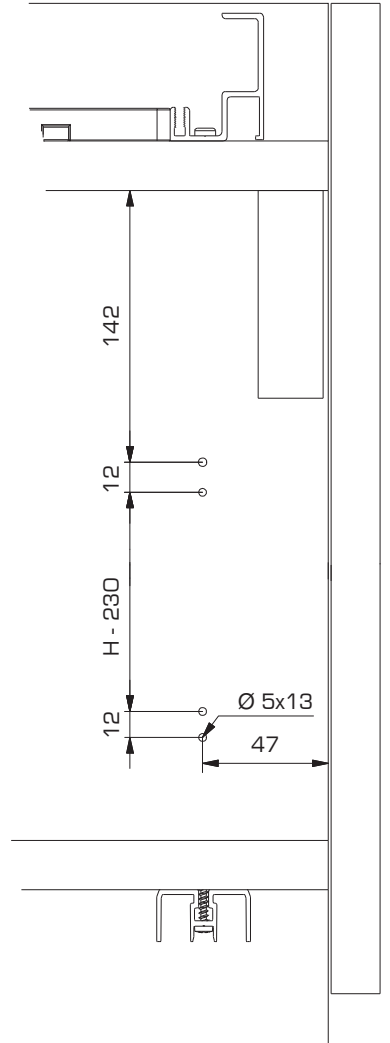

⊕ PZ No.2
 □ Ø 6.3 x 13.5

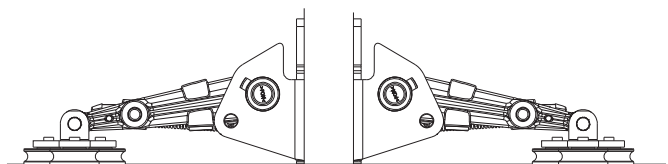
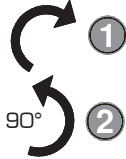

K

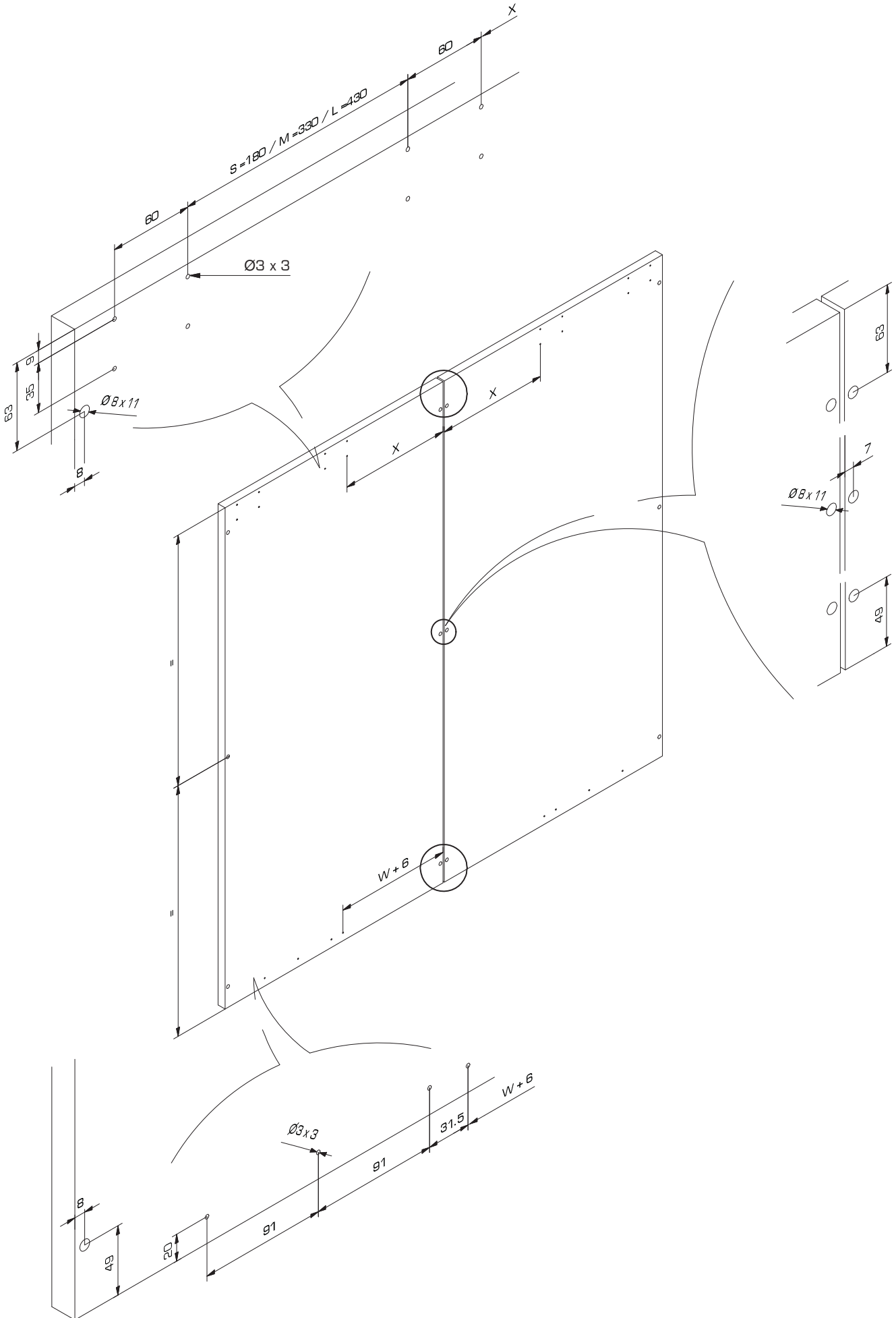

L

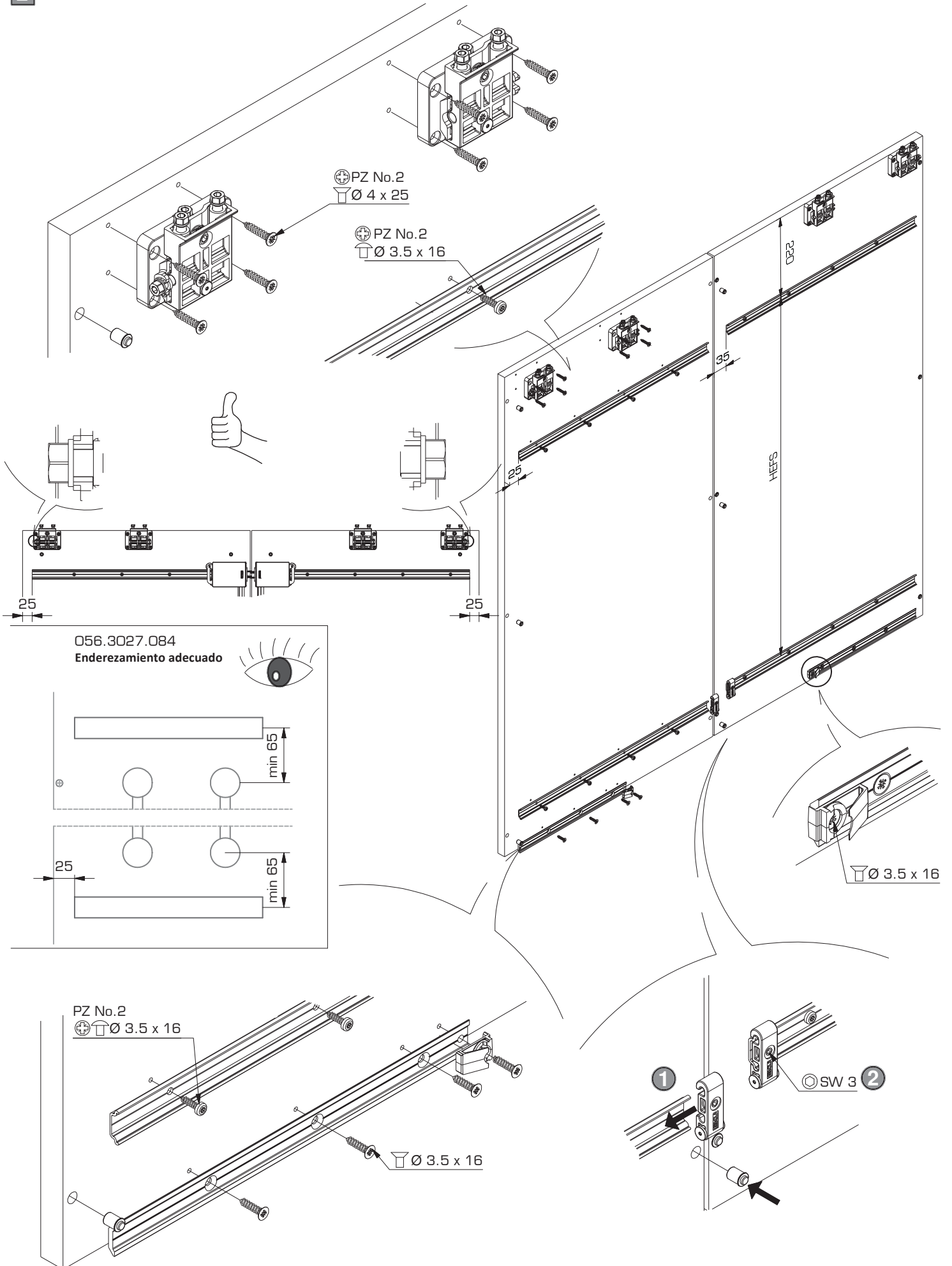

M Puerta

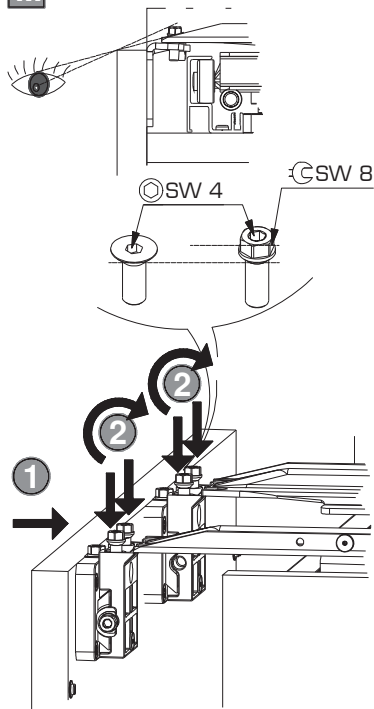

O Ajustes

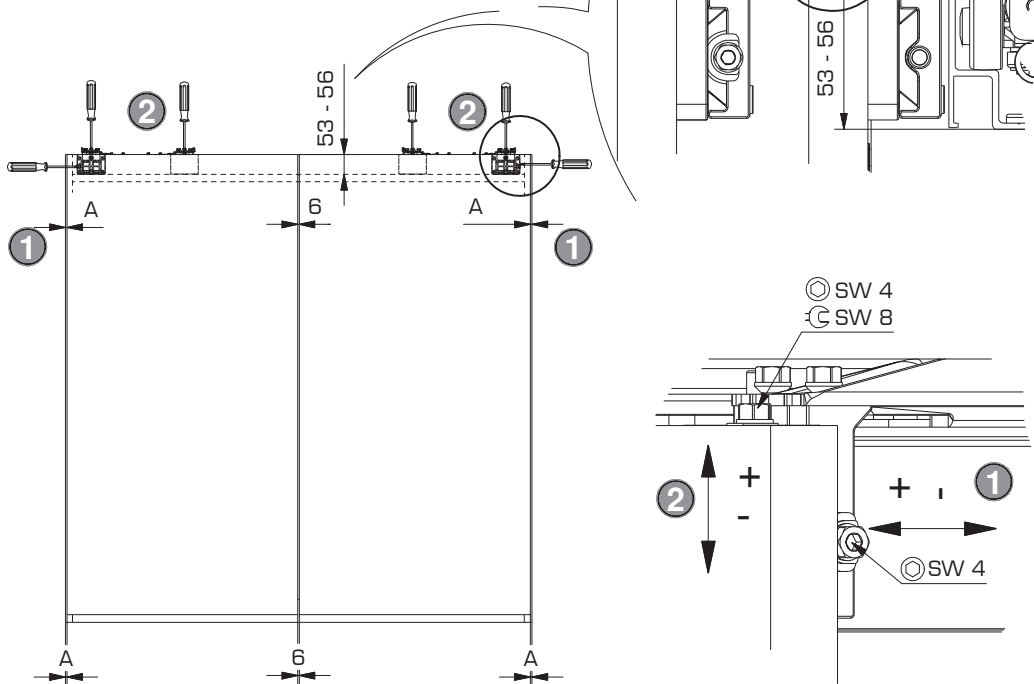

N

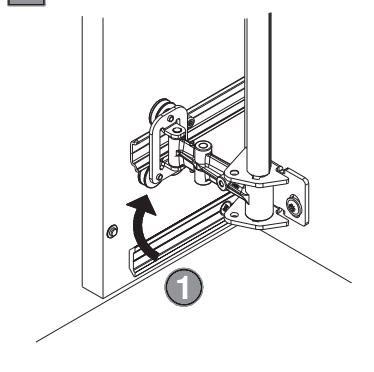

P

P - S

1x izquierda 1x derecha

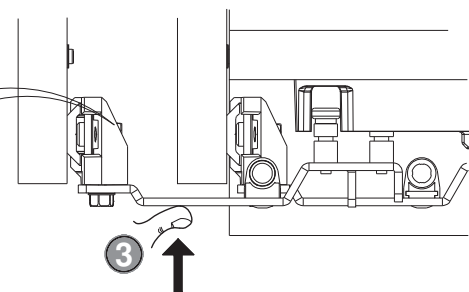
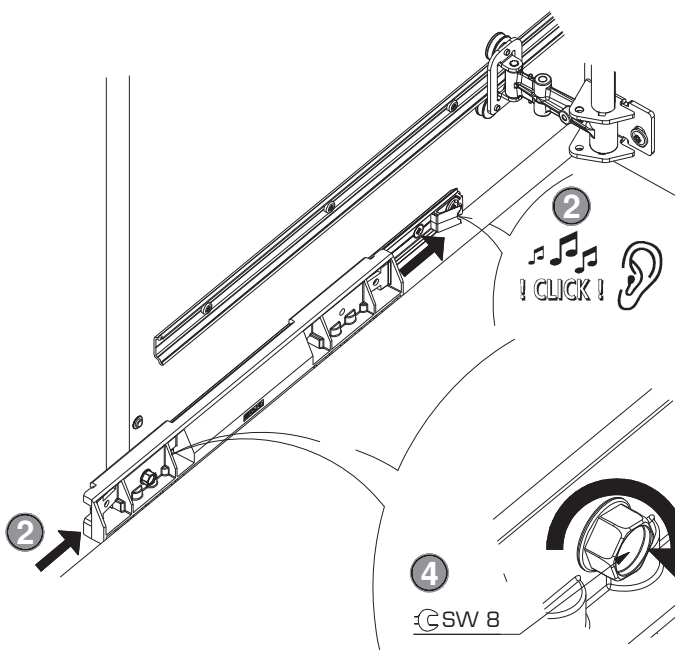
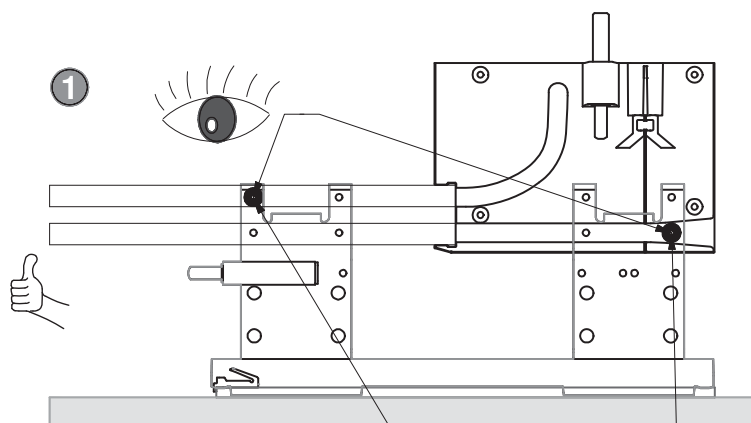

Q Cierre la puerta

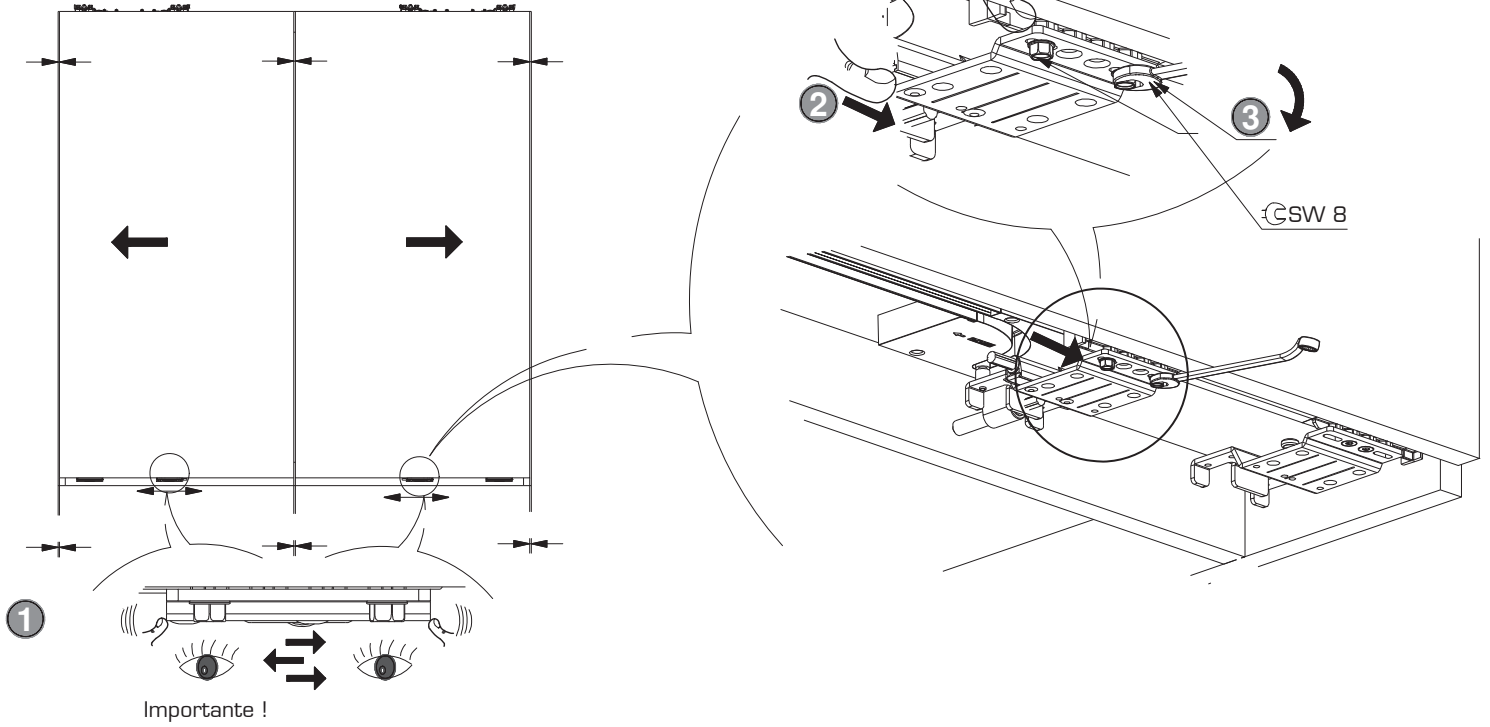

R

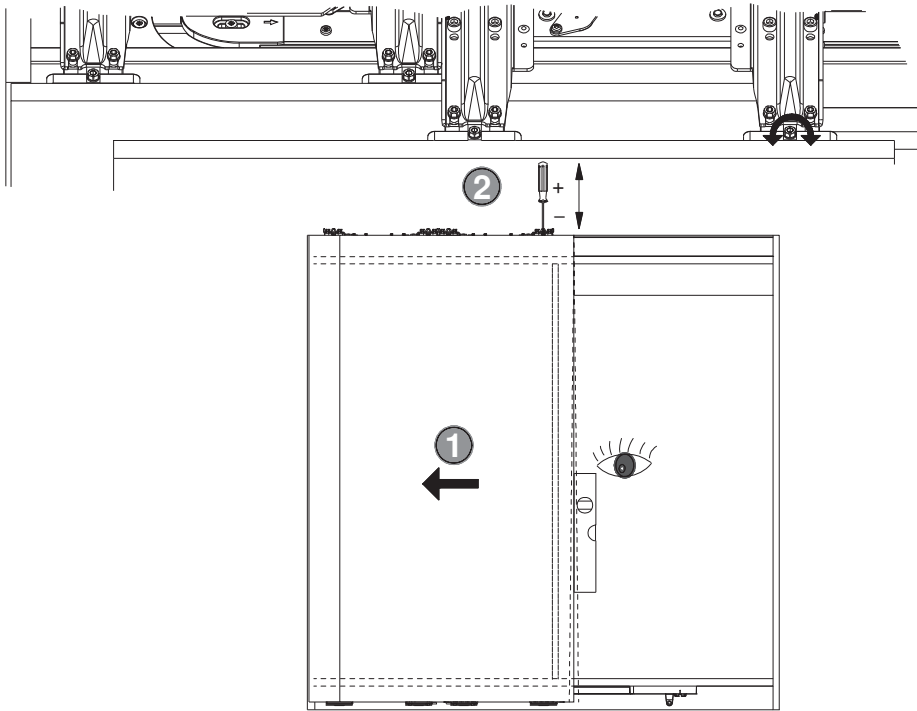

S

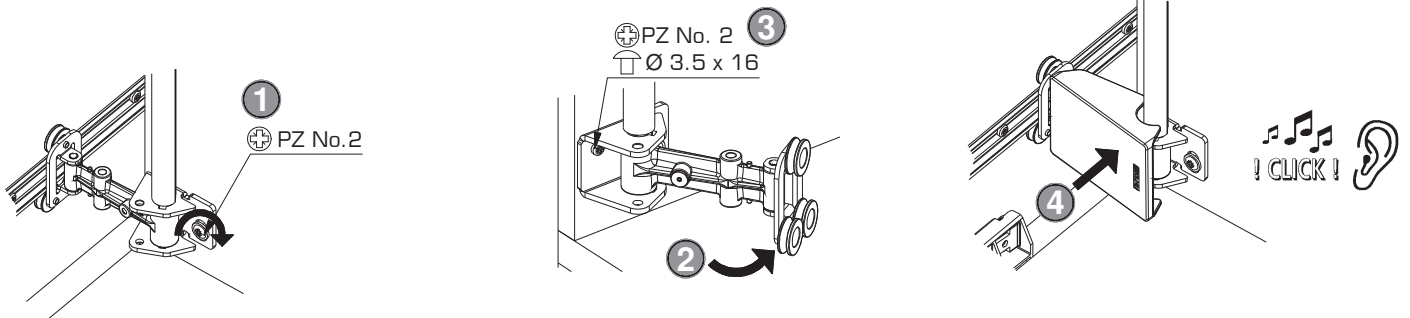

Ejemplos de montaje

