

PERFIL "GOLA"

VERTICAL L & C SHAPE "GOLA" PROFILE

Especificaciones Técnicas...

- Material: Aluminio
- Rendimiento: Extrusión de aluminio con acabados anodizado de alta calidad
- Medio Ambiente: Materiales 100% reciclables

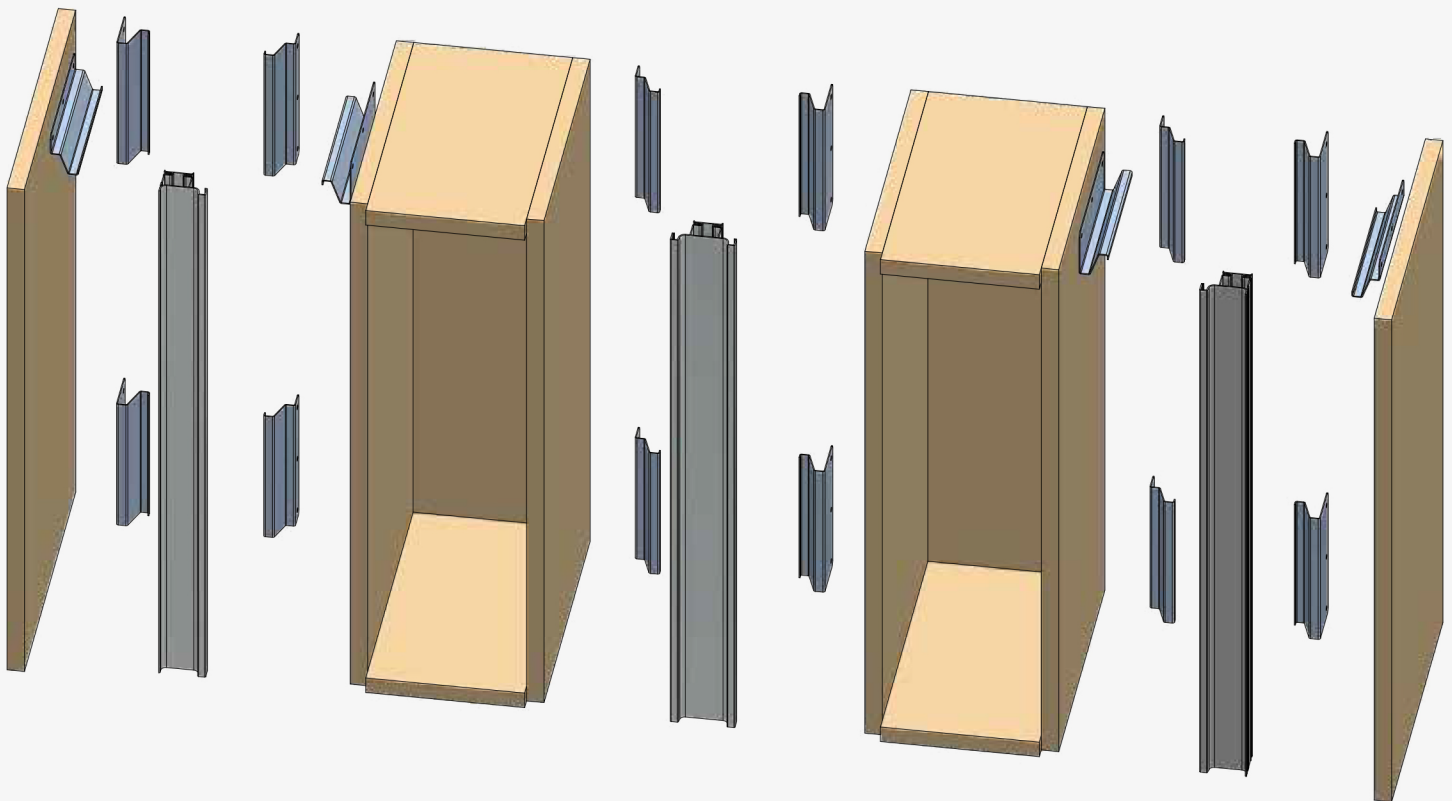

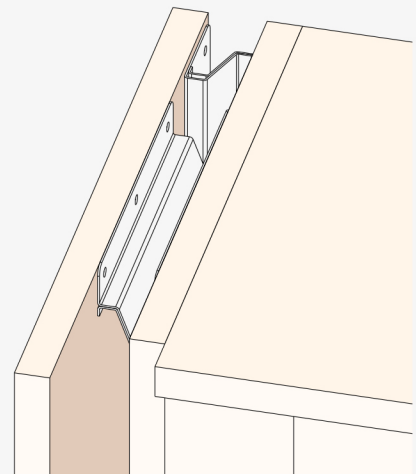
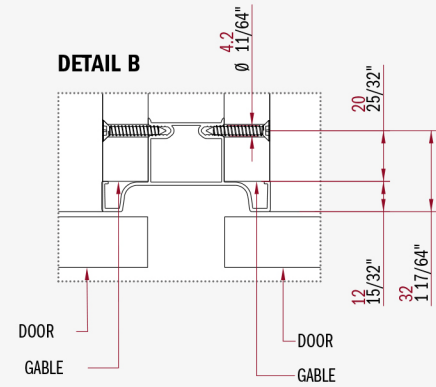
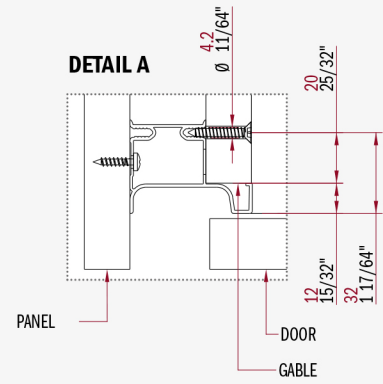
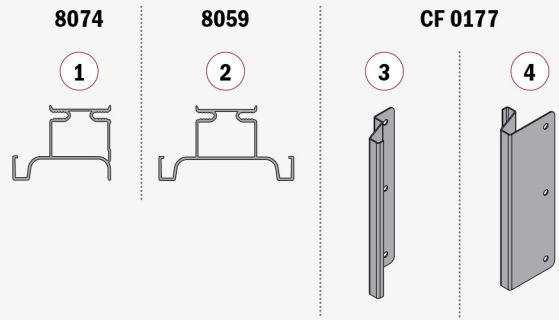
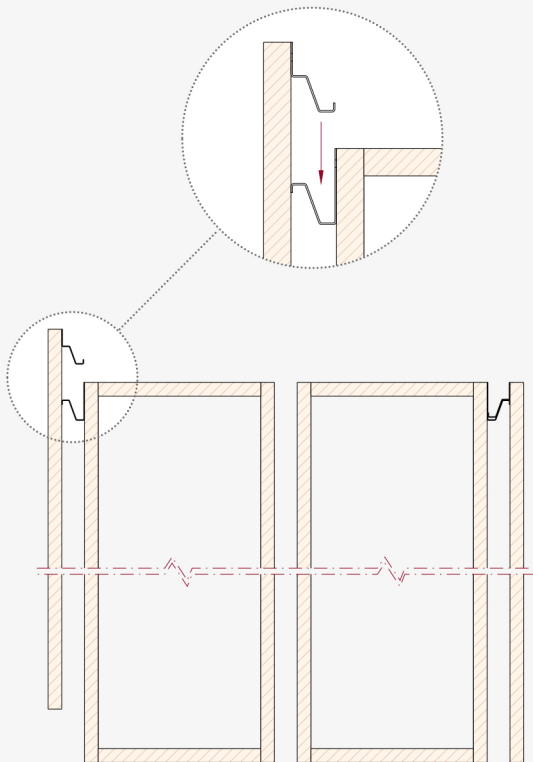
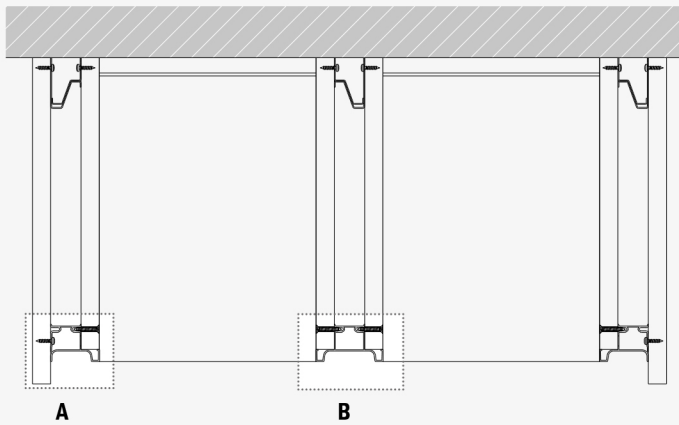
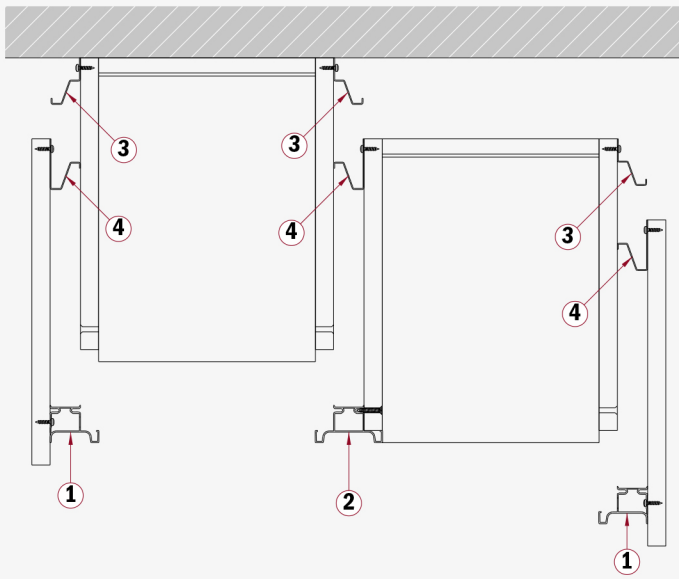

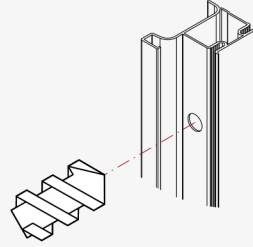
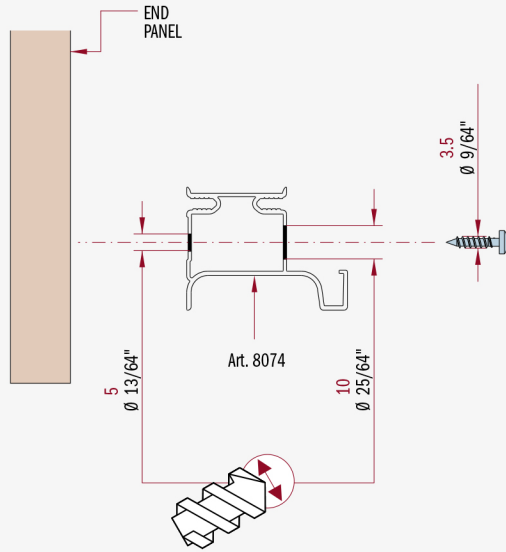

STEP 1

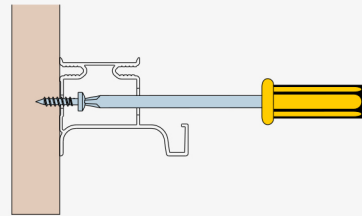

STEP 2

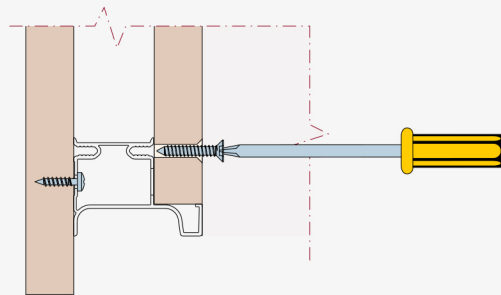
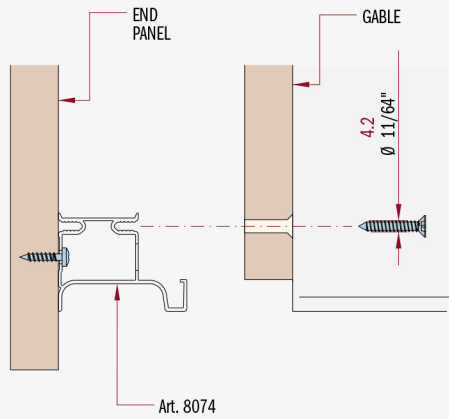

STEP 3

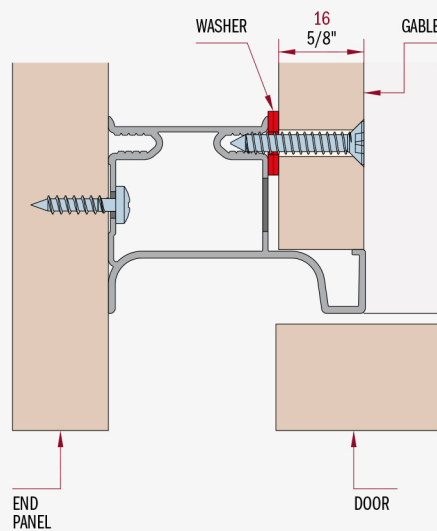
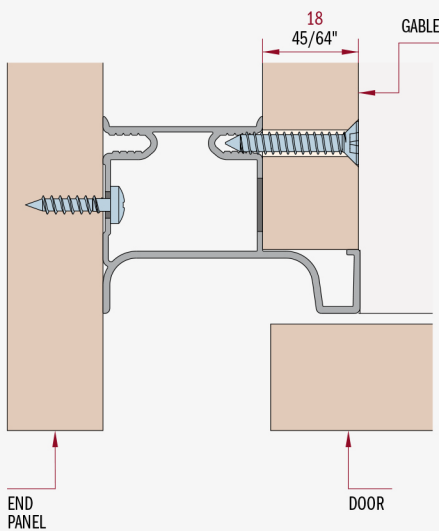

For 16mm - 5/8" gables, use a 2mm - 5/64" spacer between the Gable and the Gola profile

Pour les côtés de 16mm - 5/8", utilisez un espaceur de 2mm - 5/64" entre le côté et le profilé Gola

Para los costados de 16mm - 5/8", use un grosor de 2mm - 5/64" entre el costado y el perfil Gola