

BODY PARTS

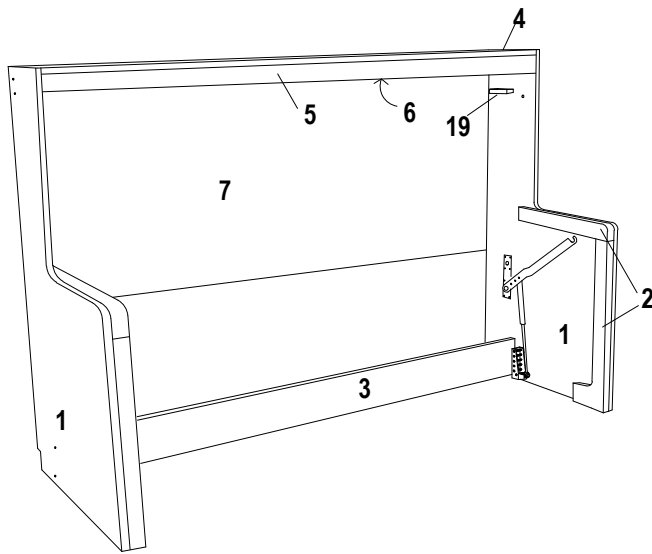

Body Parts List/ Lista de partes

Part N° N° de Parte	Name Nombre	Qty. Cant.	Pg.
1	Body Side L/R	2	1
2	Body Side Concealer	2	2
3	Bottom Stretcher	1	3
4	Body Top	1	4
5	Top Stretcher	1	5
6 (*)	Top Stiffener /Metal	1	6
7	Body Back	1	7
19	Bed Stop	2	19

(*) SEE ITEM #940.84.253

BED PARTS

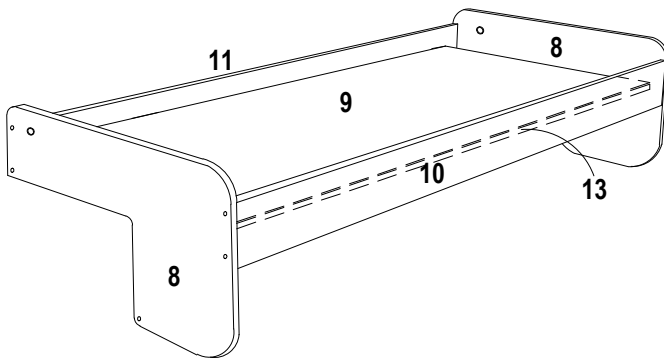

Bed Parts List/ Lista de partes

Part N°	Name	Qty.	Pg.
8	Bed Head L/R	2	8
9	Slats Cover Sheet	1	9
10	Front Bed Rail	1	10
11	Rear Bed Rail	1	11
13	Slats Cleats	2	13

DESK PARTS

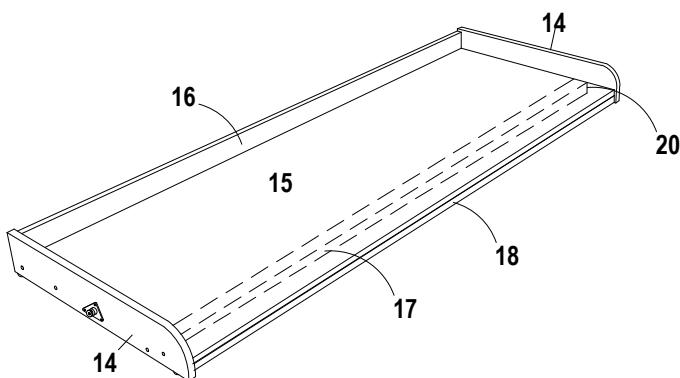

Desk Parts List/ Lista de partes

Part N°	Name	Qty.	Pg.
14	Desk Side L/R	2	14
15	Desk Top	1	15
16	Desk Back	1	16
17(*)	Desk Stiffener /Metal	1	17
18	Tube Cover	1	18
20	WP Plug	2	20

(*) SEE ITEM # 940.84.253

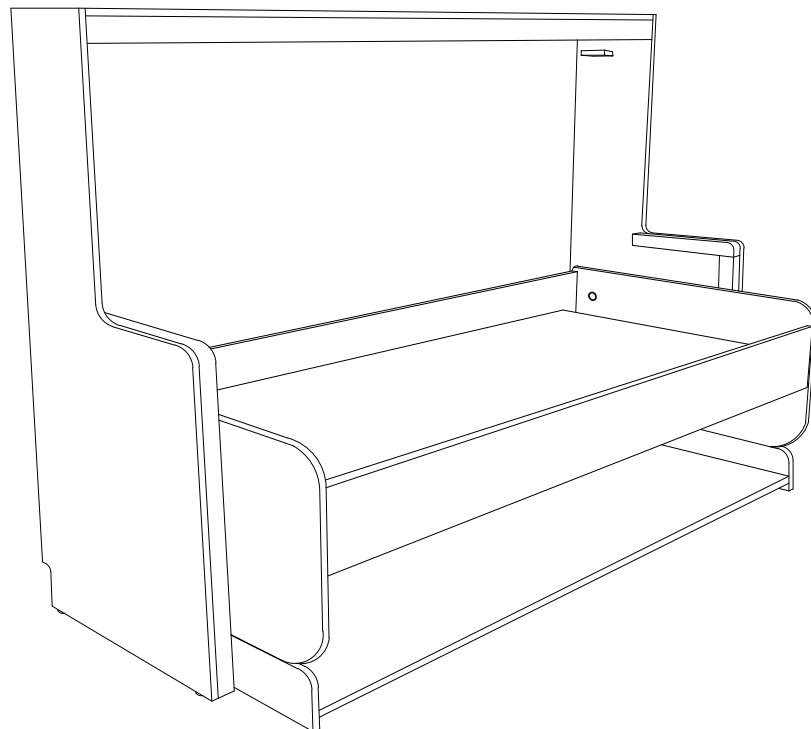
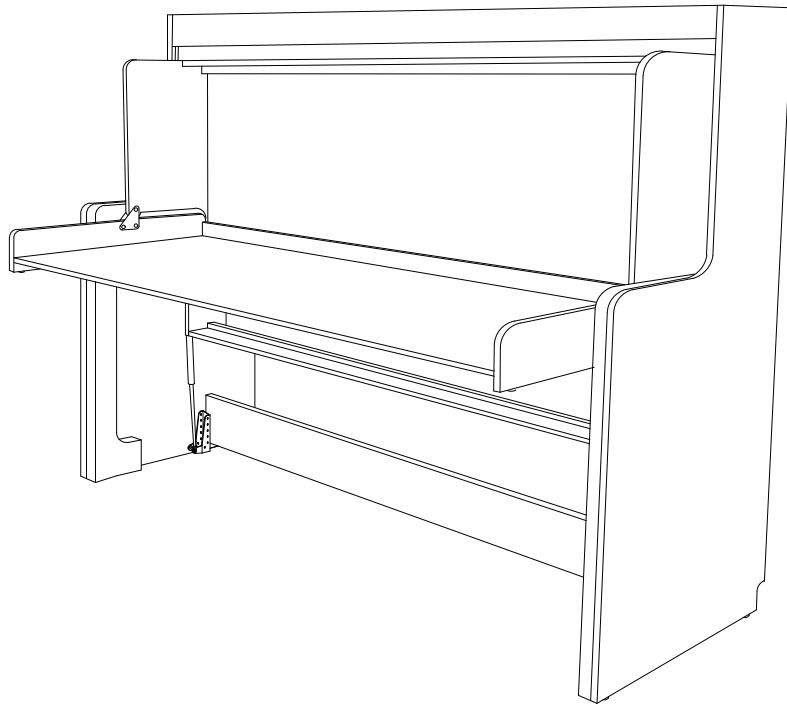





LONDON
1000 X 1900

Manufacturer to verify adequate drilling diameter and depth for screw or dowel length in every place.
El fabricante deberá verificar el adecuado diámetro y profundidad de las perforaciones para cada tornillo o tarugo.

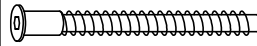
⊕ Drill to drive a screw position

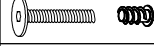
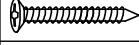
○ Drill for screw through position.

Name	Code	Dimension	Quantity	Sketch
Confirmat	H2	7 x 70	65	
Screw, Ph Head	H10	4,5 x 45	18	
Flat Head Allen & T nut	H11	6 x 15	24	
Screw, Ph head	H14	4,5 x 35	45	
Screw, Ph head	H9	4,5 x 20	2	

Drawing	Screw	Quantity
1	H2 H11	28 24
2	H10	18
3	---	---
4	H2 H14	3 6
5	---	---
6	H14	4
7	---	---
8	H2	16
9	H14	12
10	---	---
11	---	---
12	---	---
13	H14	14
14	H2 H9	14 2
15	---	---
16	H2	4
17	---	---
18	H14	5
19	---	---
20	H14	4
TOTAL		154

BED POSITION

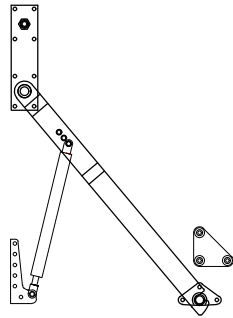

DESK POSITION

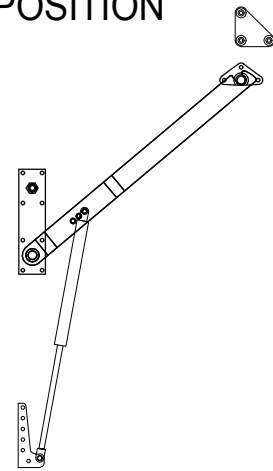

MECHANISM FIXING

S2 SCREWS RESUME:
(INCLUDED IN S1)

Carapaces

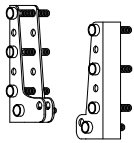

Name	Code	Dimension	Quantity	Sketch
Flat Head Allen & T nut	H11	6 x 15	8	

Plate

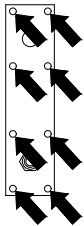

Name	Code	Dimension	Quantity	Sketch
Flat Head Allen & T nut	H11	6 x 15	16	

Tribearer

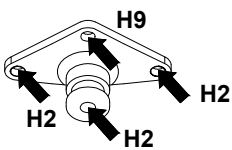

Name	Code	Dimension	Quantity	Sketch
Screw, Ph head	H9	4,5x20	2	
Confirmat	H2	7 x 70	6	

DESK POSITION:
POSICIÓN ESCRITORIO

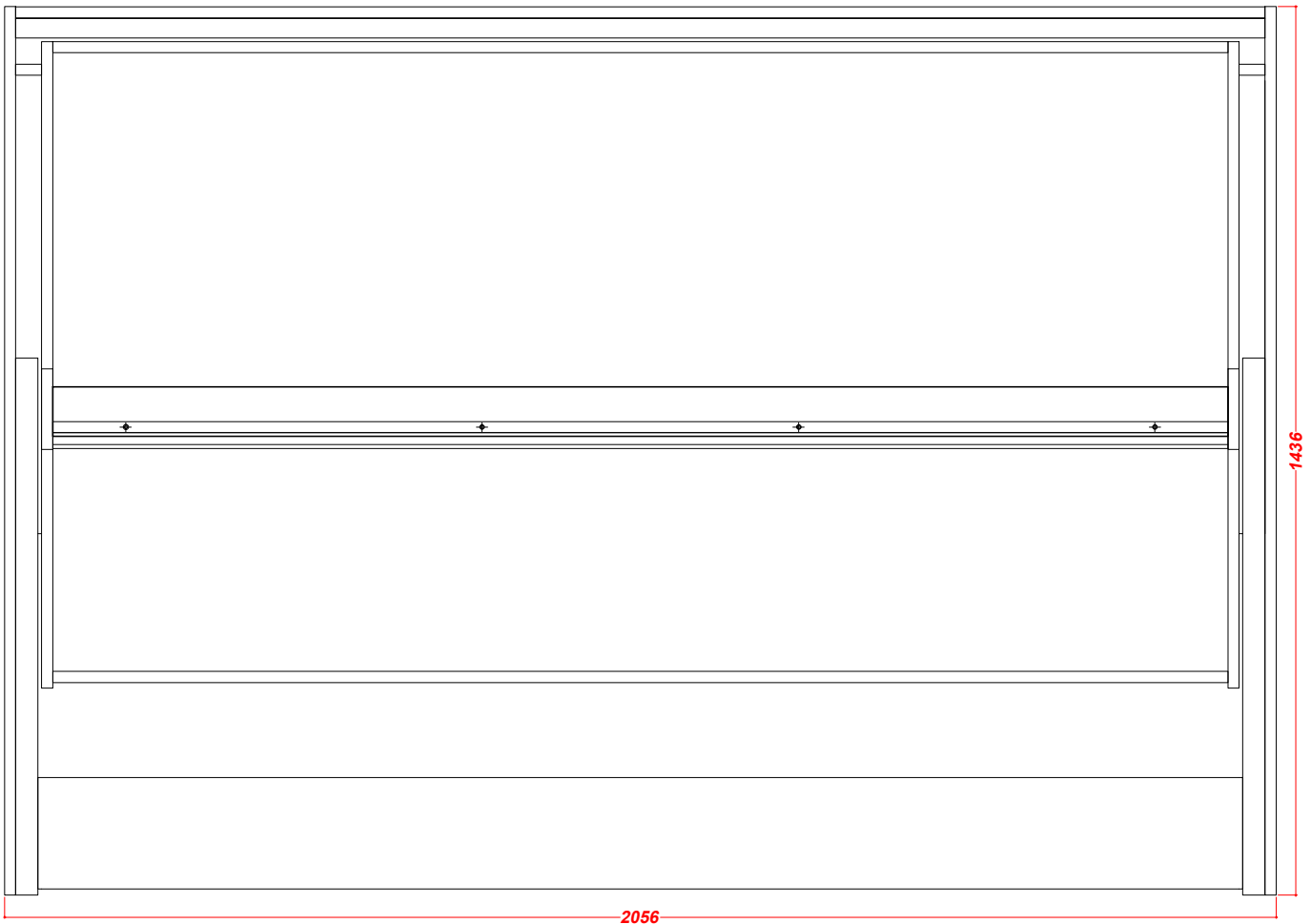
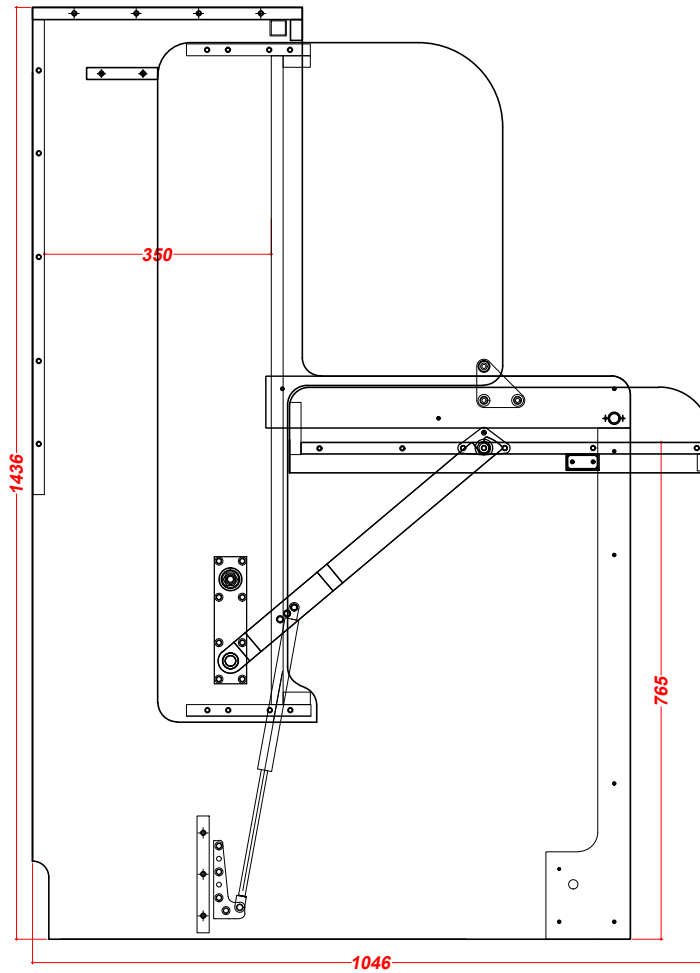

BED POSITION:
POSICIÓN CAMA

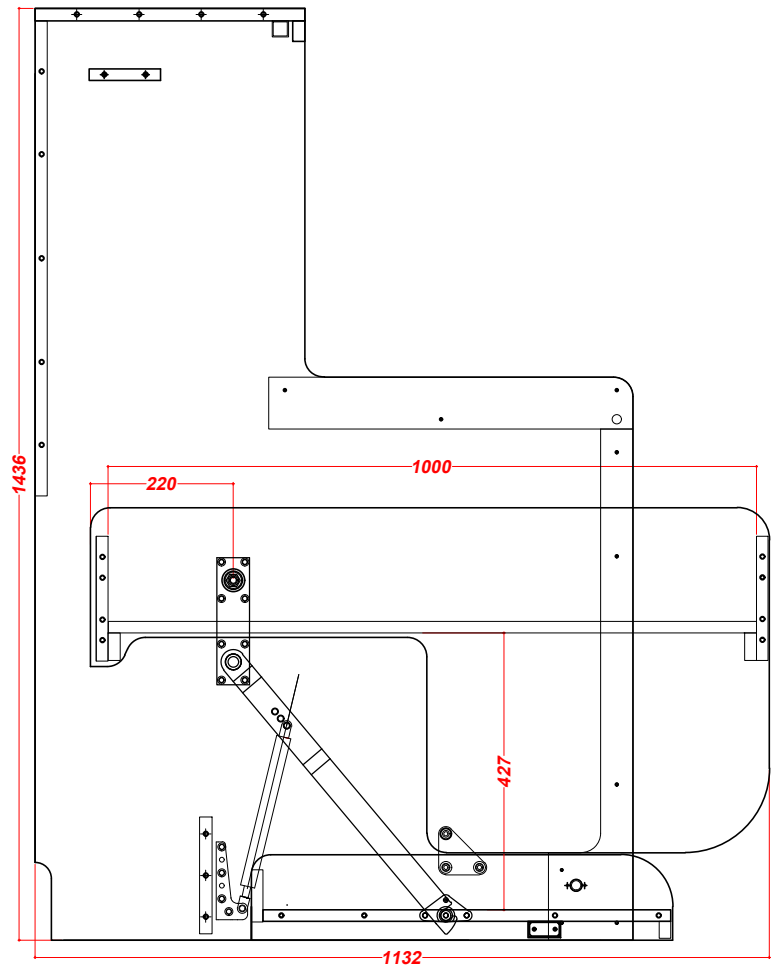

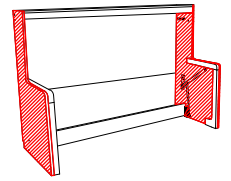

Part: Body Side (1)

Material: MDF

Thick: 18mm

Quantity: 2

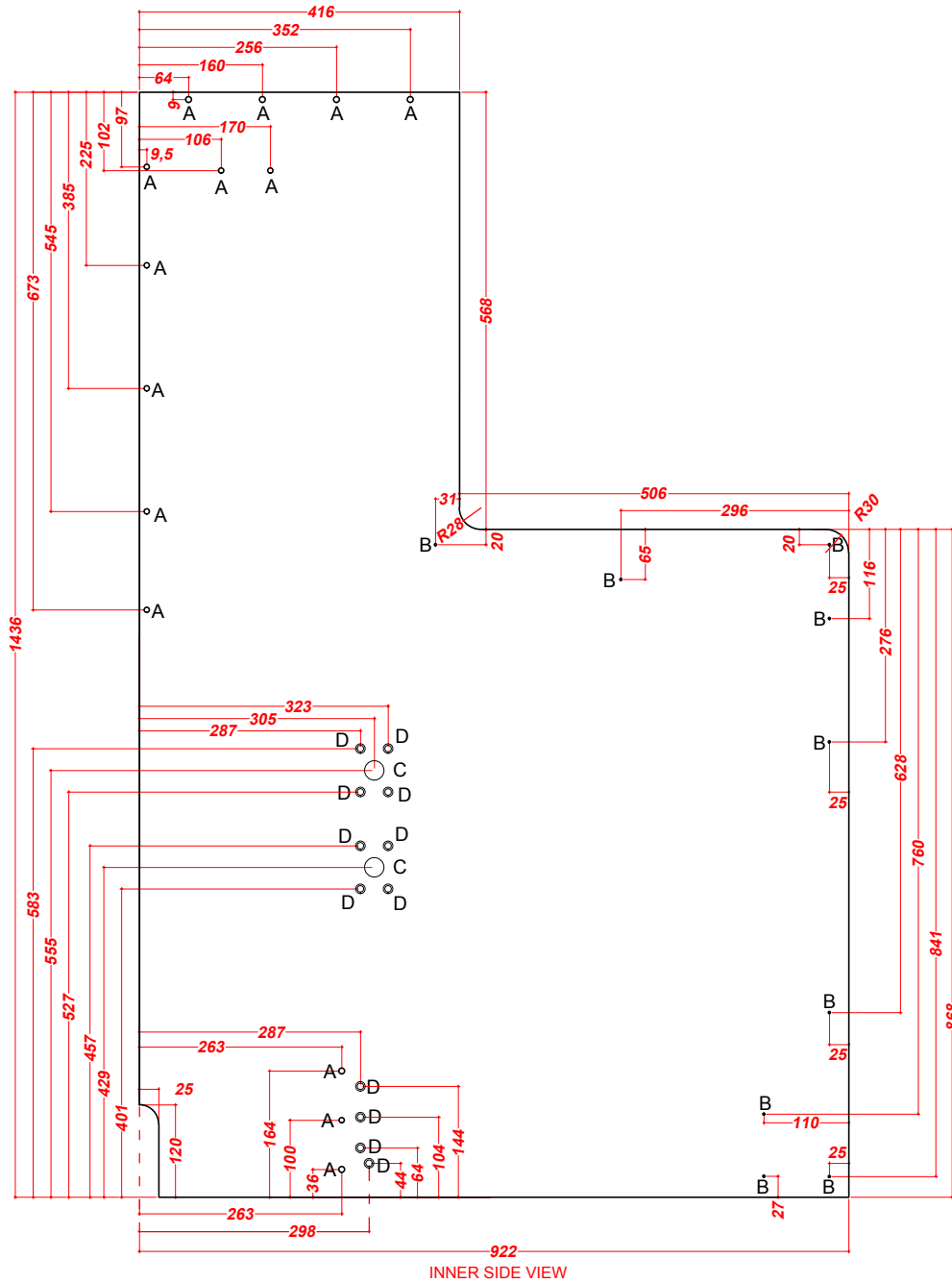

SCREW HEADS

PERFORATION

A	7	PASS
B	3	2
C	25	10
D	12	2
Milling	8	13



CONFIDENTIAL DRAWINGS
ALL REPRODUCTION PROHIBITED

Mecanismo London

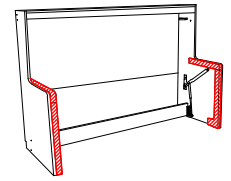

Part: Concealer (2)

Material: MDF

Thick: 36mm

Quantity: 2

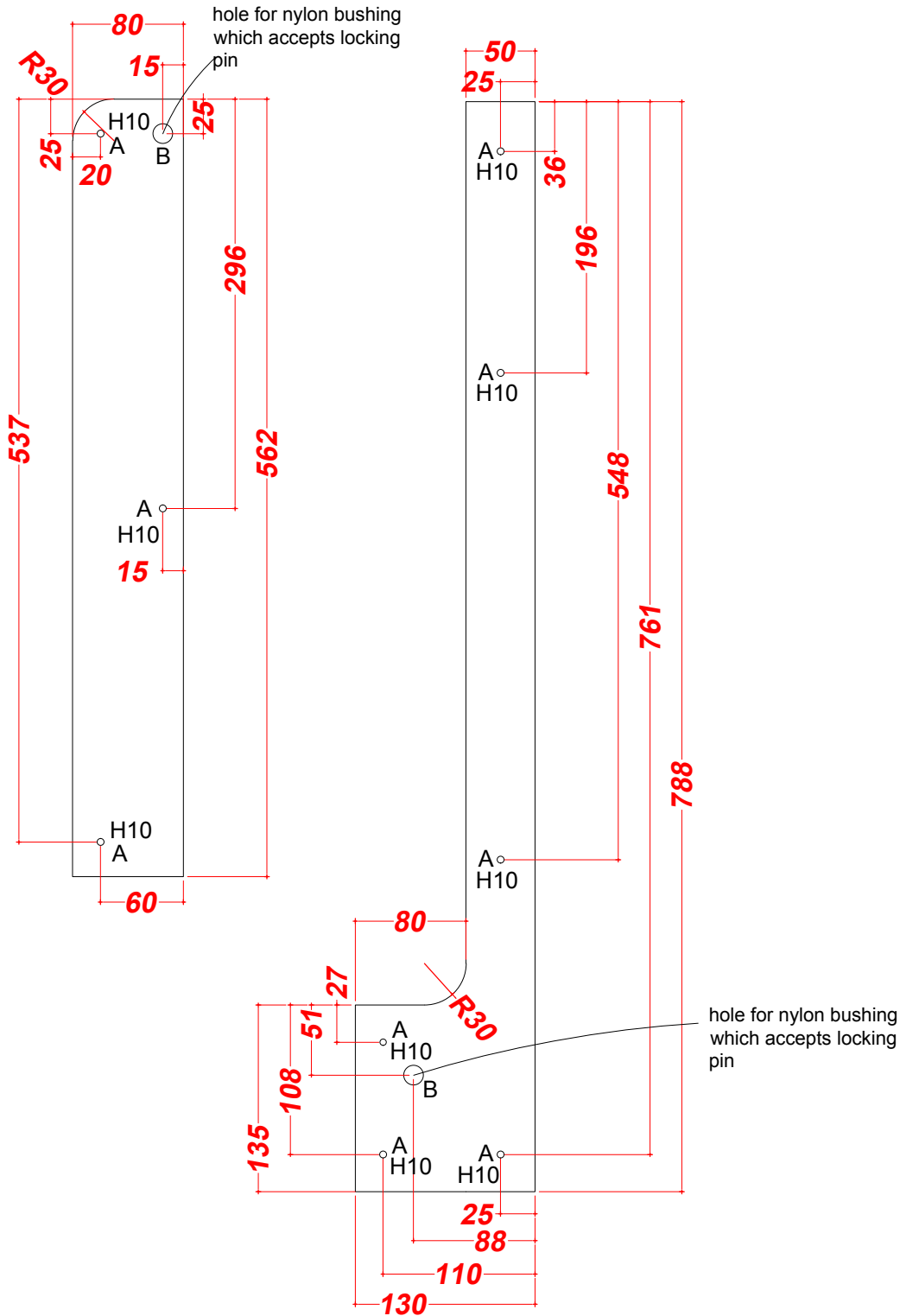

SCREW HEADS

H10	9 x 2
-----	-------

PERFORATION

A	5	PASS
B	14	PASS



CONFIDENTIAL DRAWINGS
ALL REPRODUCTION PROHIBITED

Mecanismo London

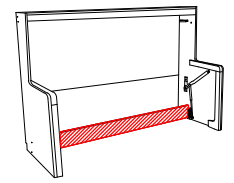

Part: Bottom Stretcher(3)

Material: MDF

Thick: 18mm

Quantity: 1

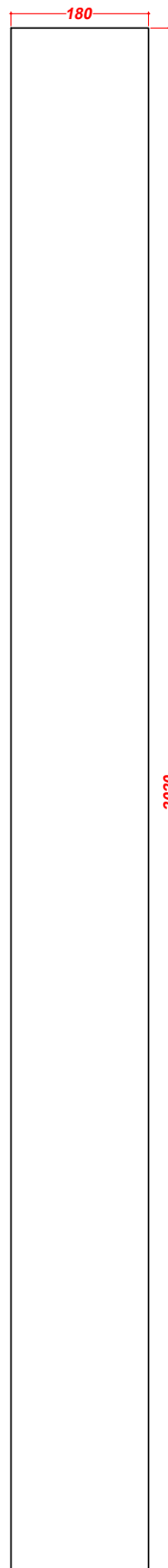

BOTH ENDS
AMBOS EXTREMOS

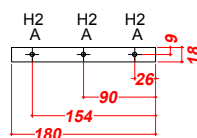

SCREW HEADS

PERFORATION

A	5.5	70



CONFIDENTIAL DRAWINGS
ALL REPRODUCTION PROHIBITED

Mecanismo London

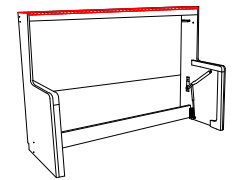

Part: Body Top (4)
 Material: MDF
 Thick: 18mm
 Quantity: 1

SCREW HEADS

H2	3
H14	6

PERFORATION

A	5.5	70
B	7	PASS
C	3	2
D	5	PASS

FRONT

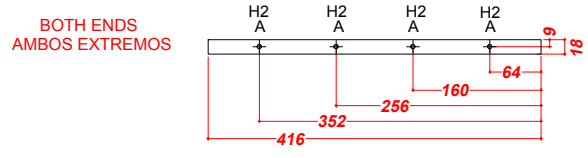
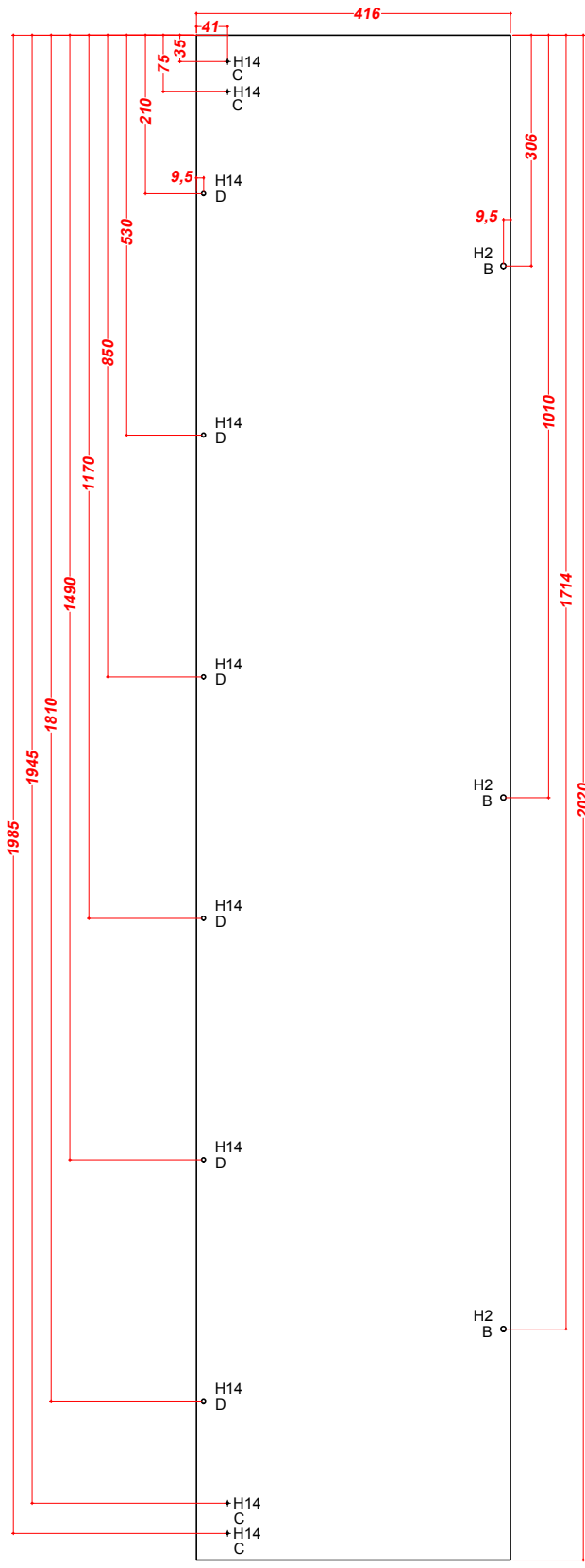

CONFIDENTIAL DRAWINGS
 ALL REPRODUCTION PROHIBITED

Mecanismo London

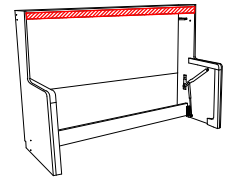

Part: Top Stretcher (5)

Material: MDF

Thick: 18mm

Quantity: 1

SCREW HEADS

PERFORATION

A	3	2

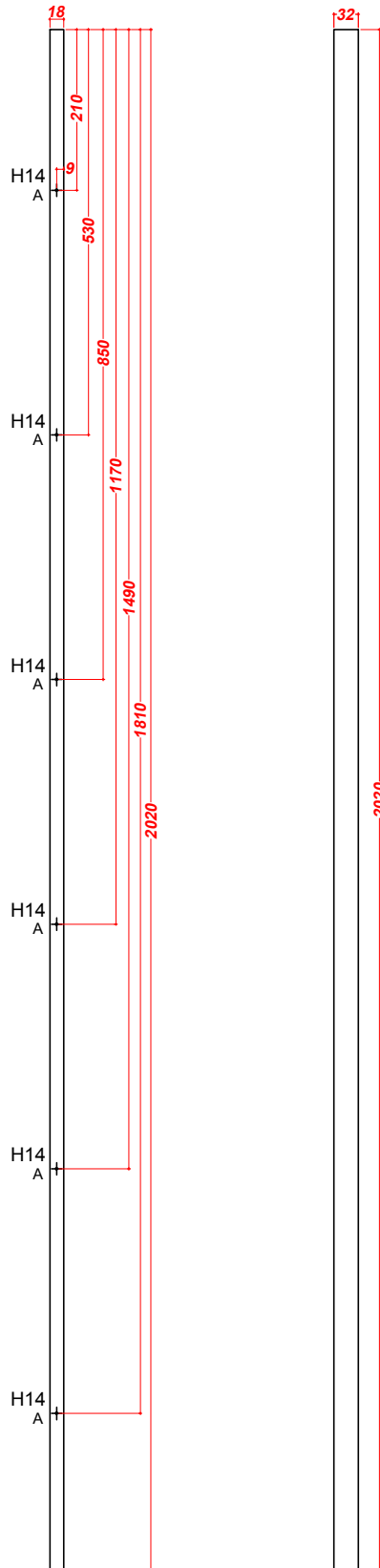

CONFIDENTIAL DRAWINGS
ALL REPRODUCTION PROHIBITED

Mecanismo London

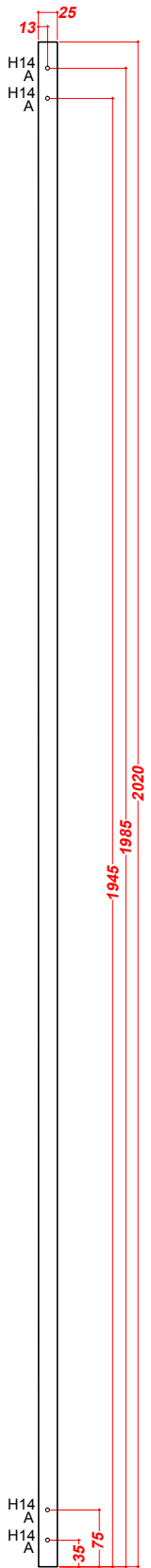
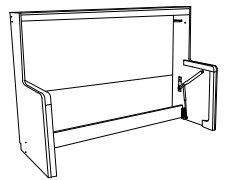

Part: Top Stiffener (6)
 Material: STEEL
 Thick: 25 x 25 x 1.6
 Quantity: 1

SCREW HEADS	
H14	4

PERFORATION		
A	5	PASS



CONFIDENTIAL DRAWINGS
 ALL REPRODUCTION PROHIBITED

Mecanismo London

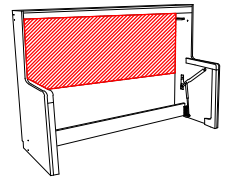

Part: Body Back (7)

Material: MDF

Thick: 18mm

Quantity: 1

SCREW HEADS

PERFORATION

A	5.5	70

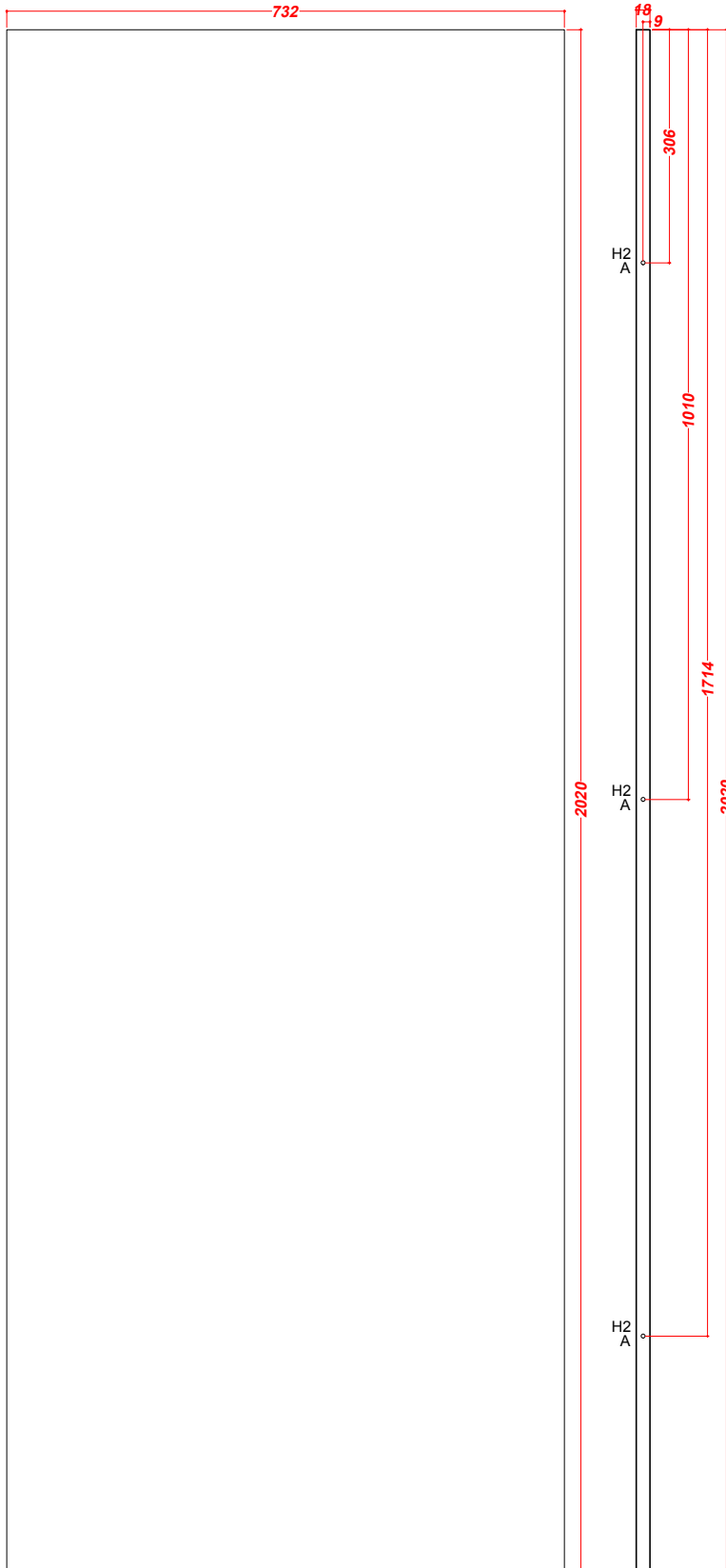

BOTH ENDS
AMBOS EXTREMOS

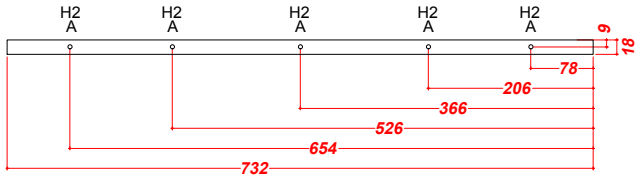

CONFIDENTIAL DRAWINGS
ALL REPRODUCTION PROHIBITED

Mecanismo London

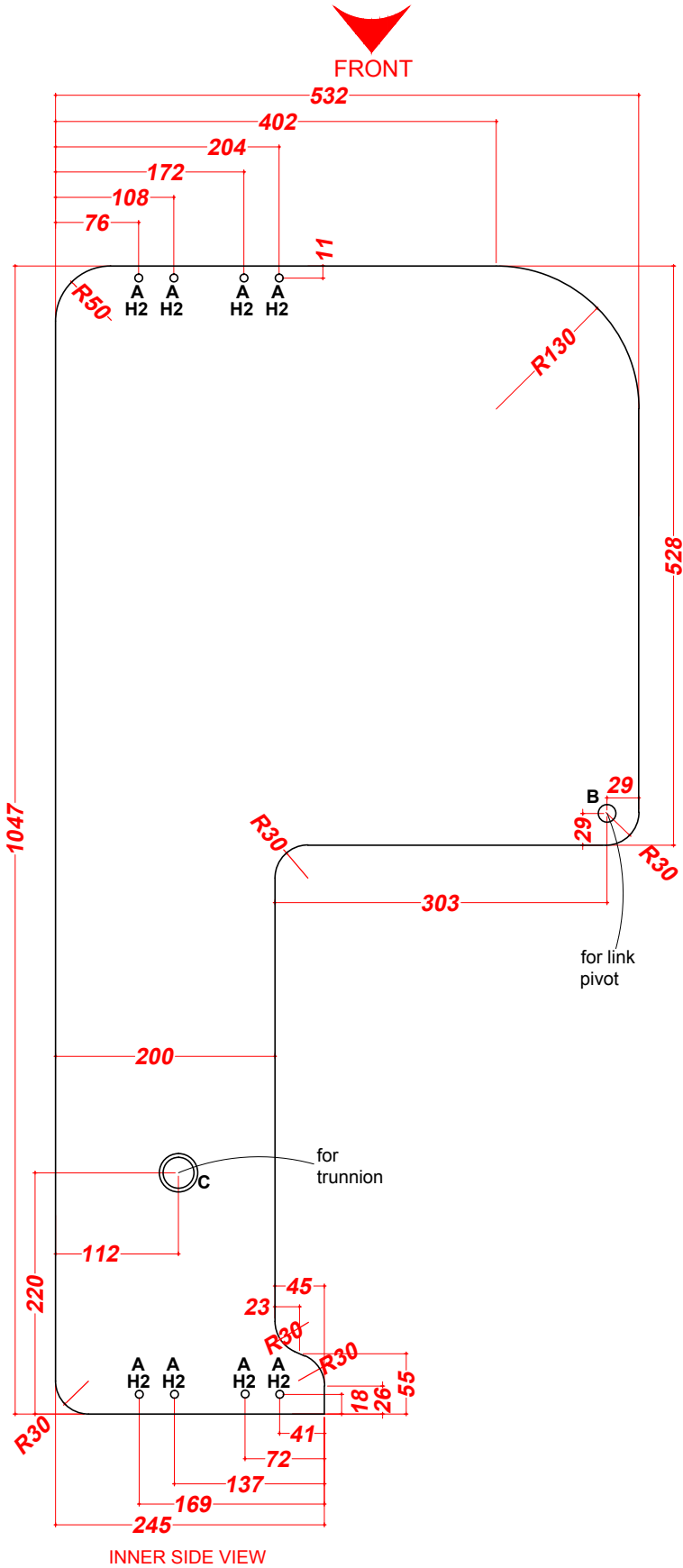
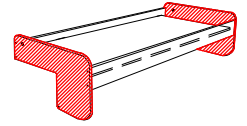

Part:Bed Head (8)

Material: MDF

Thick: 18mm

Quantity: 2

SCREW HEADS

H2	8 x 2
----	-------

PERFORATION

A	7	PASS
B	16	PASS
C	35	2
Milling	28	PASS



CONFIDENTIAL DRAWINGS
ALL REPRODUCTION PROHIBITED

Mecanismo London

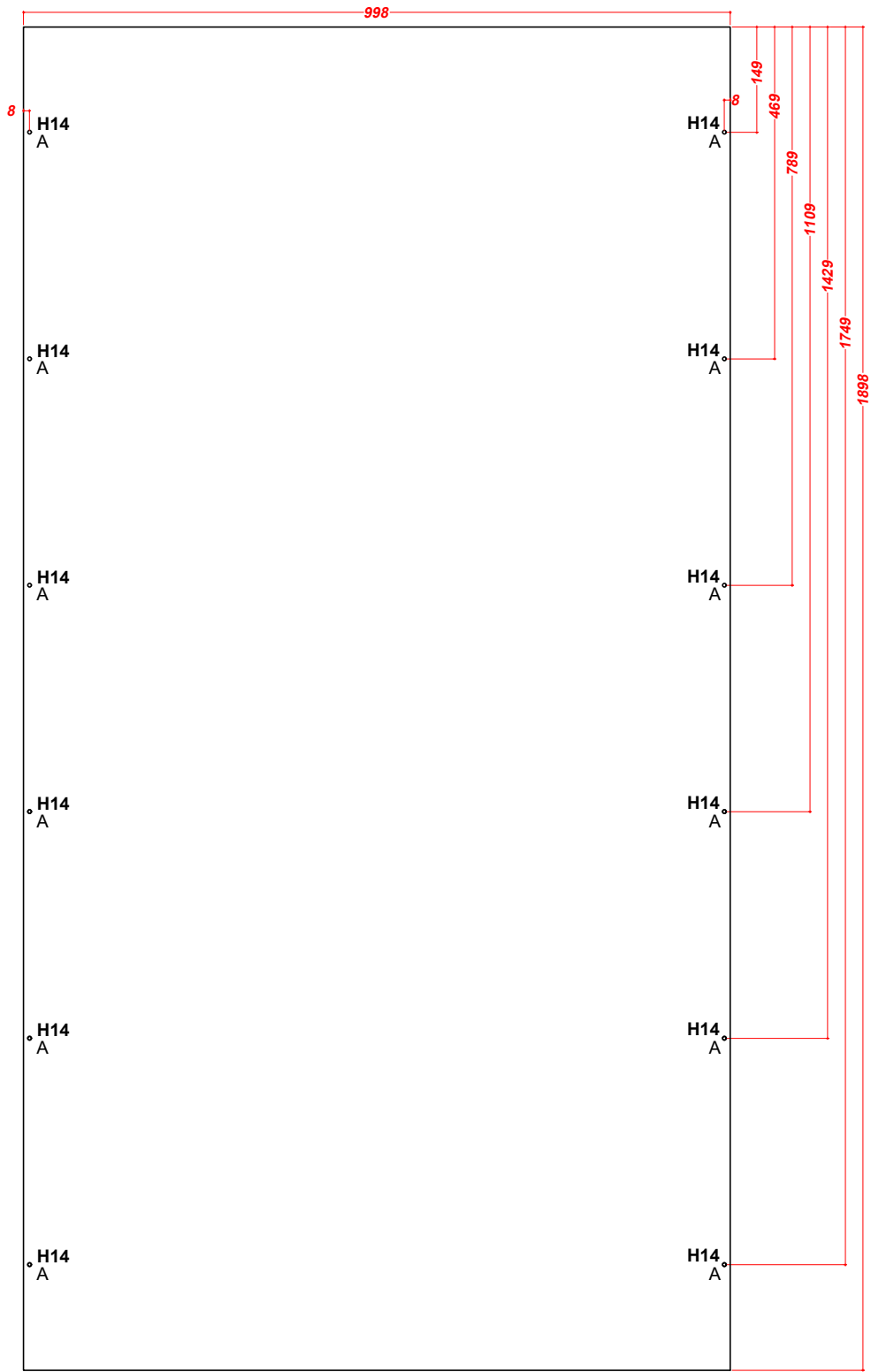
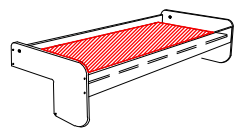

Part: Slats Cover (9)
 Material: MDF
 Thick: 18mm
 Quantity: 1

SCREW HEADS	
H14	12

PERFORATION		
A	5	PASS



CONFIDENTIAL DRAWINGS
ALL REPRODUCTION PROHIBITED

Mecanismo London
TD 06 SP 1000 x 1900 CQU

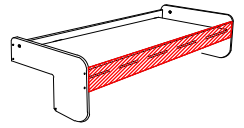

Part: Front Bed Rail (10)

Material: MDF

Thick: 18mm

Quantity: 1

SCREW HEADS

PERFORATION

A	5.5	70
B	3	2

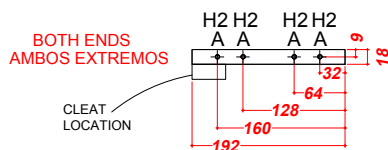
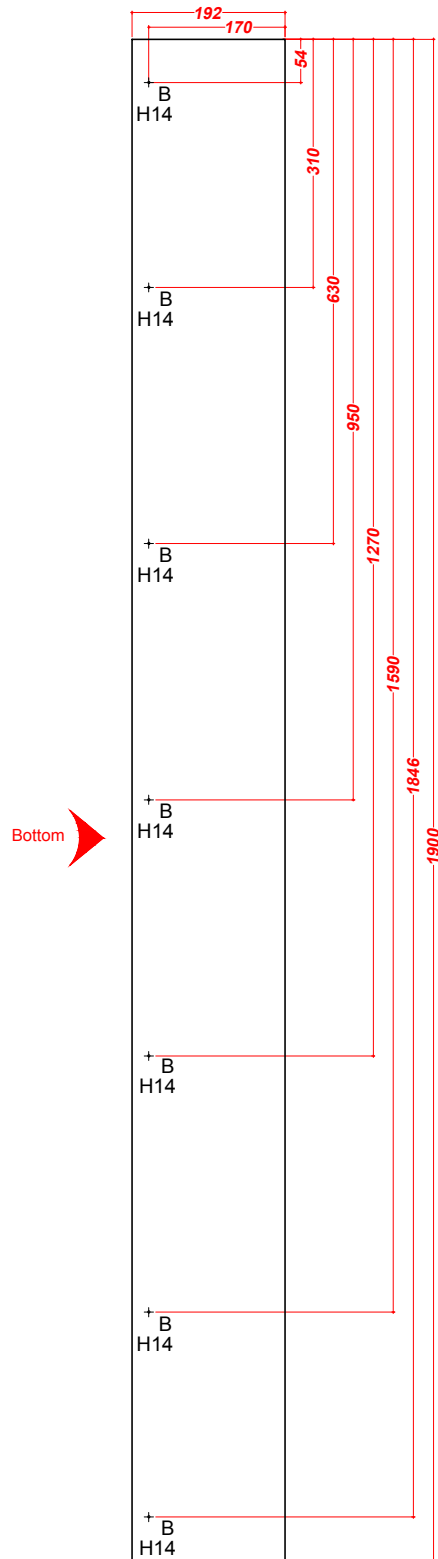

CONFIDENTIAL DRAWINGS
ALL REPRODUCTION PROHIBITED

Mecanismo London

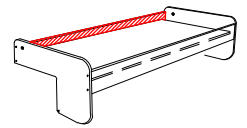

Part:Rear Bed Rail (11)

Material: MDF

Thick: 18mm

Quantity: 1

SCREW HEADS

PERFORATION

A	5.5	70
B	3	2

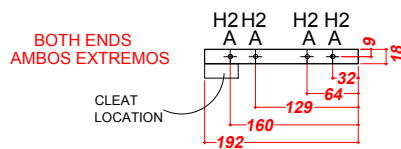
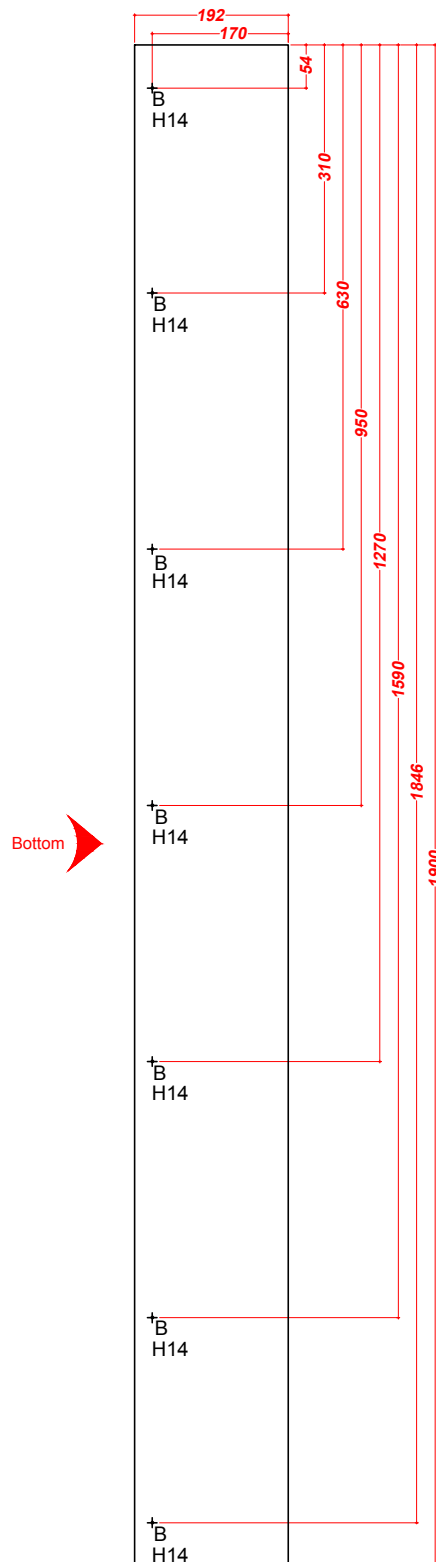

CONFIDENTIAL DRAWINGS
ALL REPRODUCTION PROHIBITED

Mecanismo Vancouver

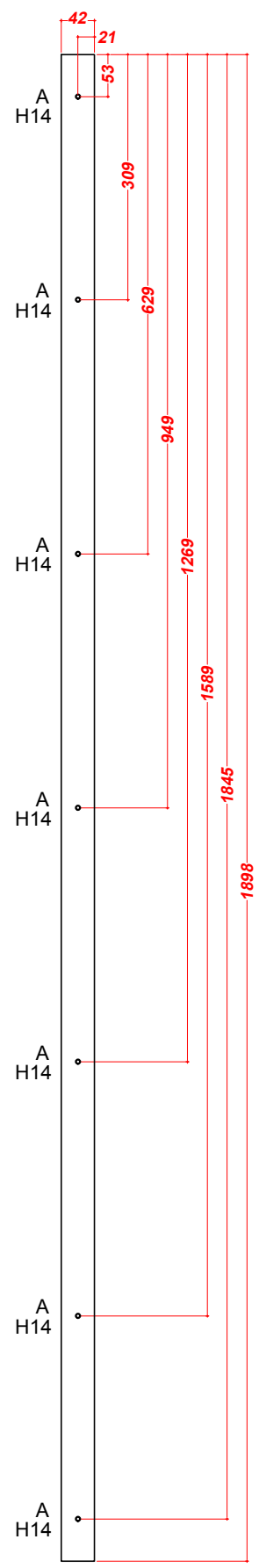
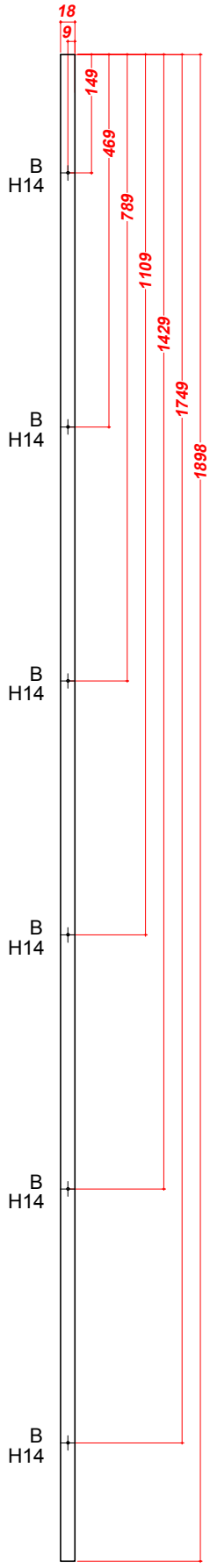
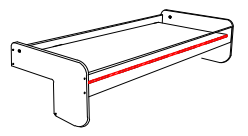

Part: Slats Cleats (13)
 Material: MDF
 Thick: 18mm
 Quantity: 2

SCREW HEADS	
H14	7 x 2

PERFORATION		
A	5	PASS
B	3	2



CONFIDENTIAL DRAWINGS
 ALL REPRODUCTION PROHIBITED

Mecanismo Vancouver

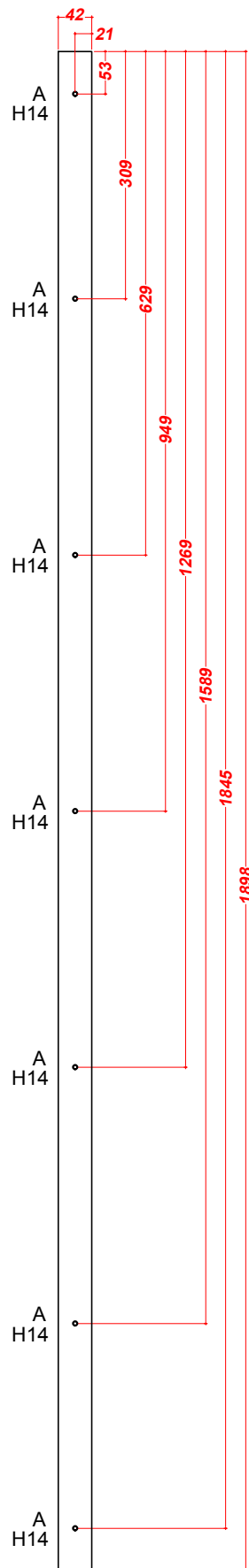
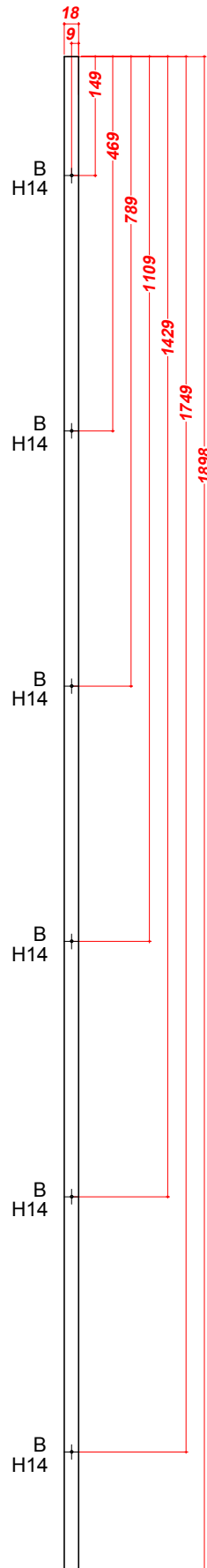
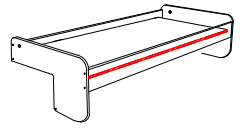

Part: Slats Cleats (13)

Material: MDF

Thick: 18mm

Quantity: 2

SCREW HEADS

H14	7 x 2
-----	-------

PERFORATION

A	5	PASS
B	3	2



CONFIDENTIAL DRAWINGS
ALL REPRODUCTION PROHIBITED

Mecanismo London

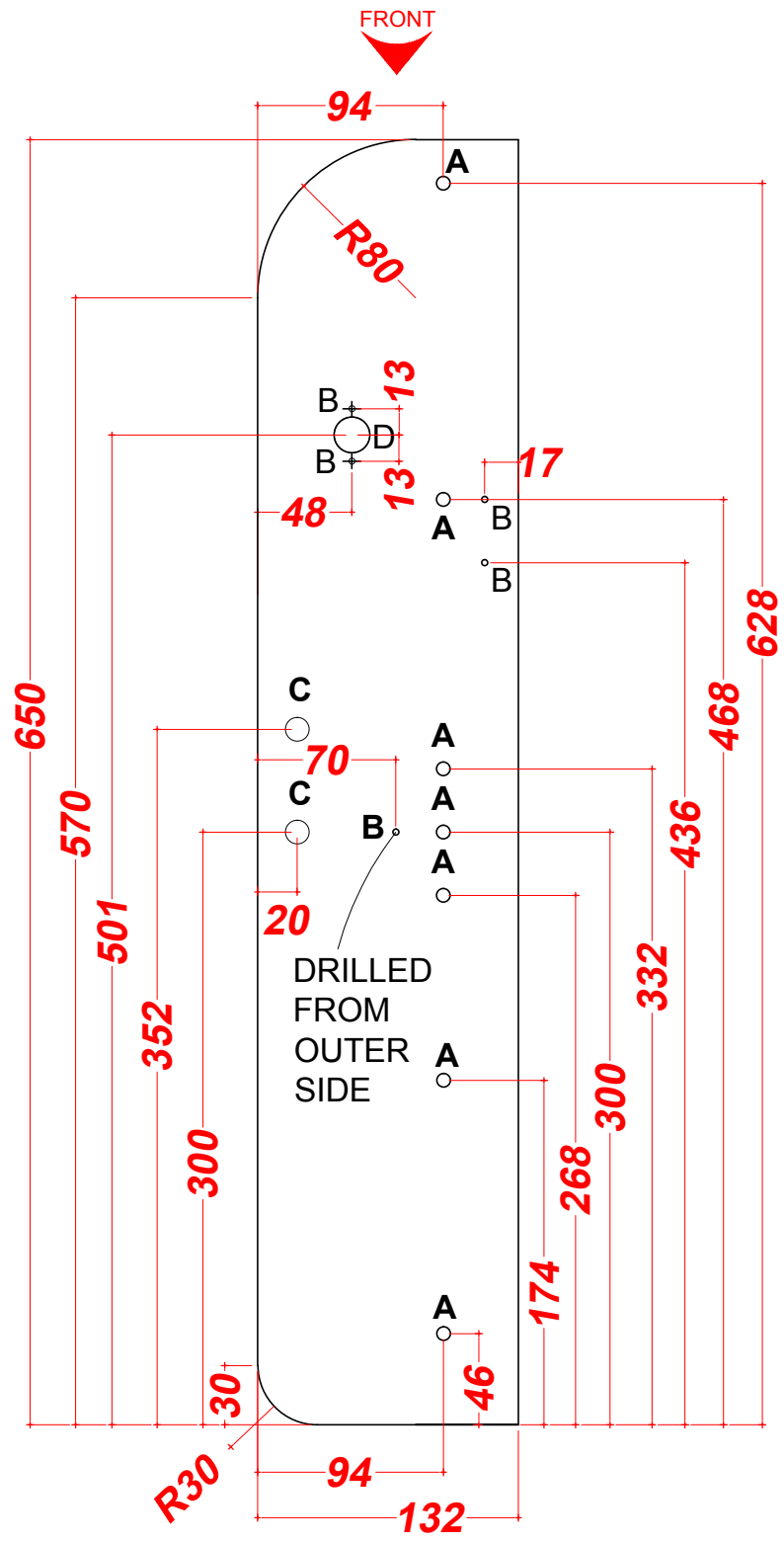
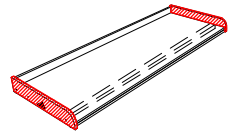

INNER SIDE VIEW

Part: Desk Side (14)
 Material: MDF
 Thick: 18mm
 Quantity: 2

SCREW HEADS

PERFORATION

A	7	PASS
B	3	2
C	12	PASS
D	18	PASS



CONFIDENTIAL DRAWINGS
 ALL REPRODUCTION PROHIBITED

Mecanismo London

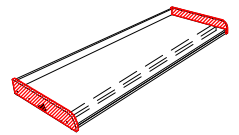

Part: Desk Side (14)
 Material: MDF
 Thick: 18mm
 Quantity: 2

FRONT

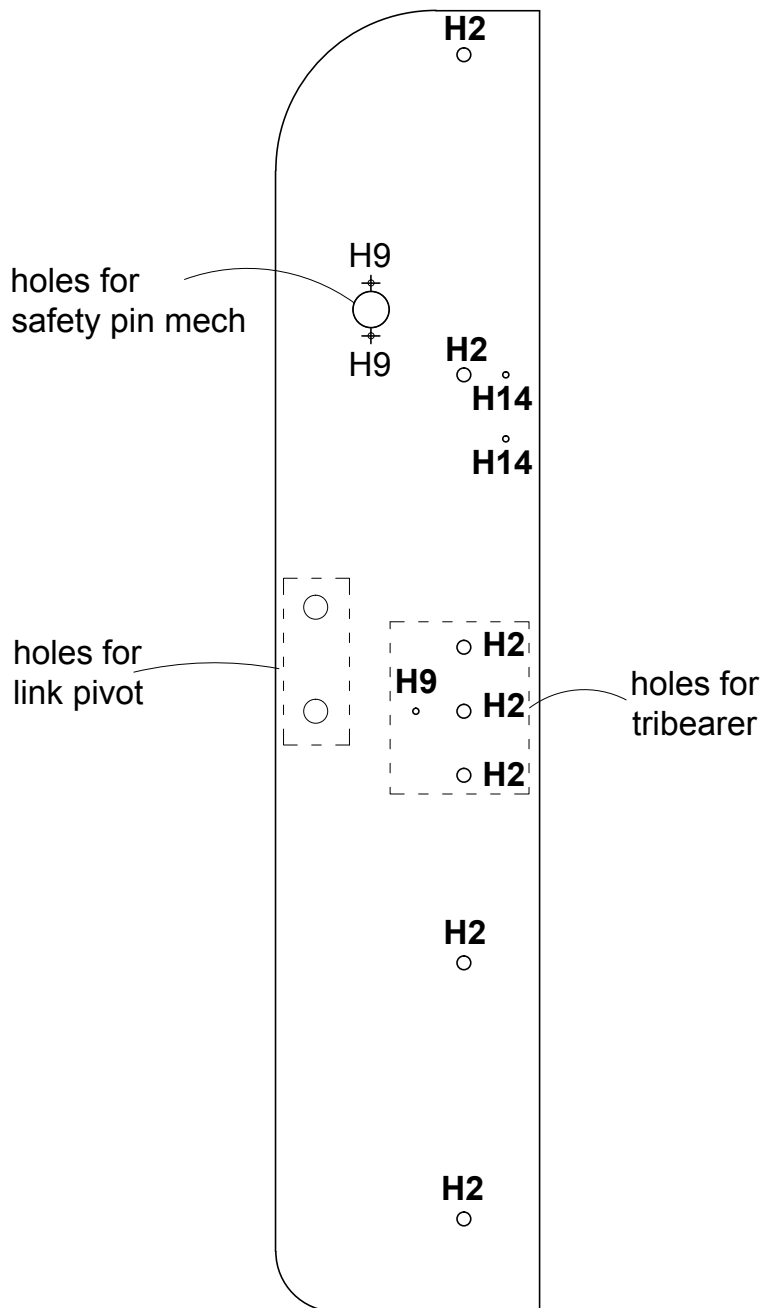

SCREW HEADS

H2 7 x 2

H9 1 x 2

PERFORATION



CONFIDENTIAL DRAWINGS
 ALL REPRODUCTION PROHIBITED

Mecanismo London

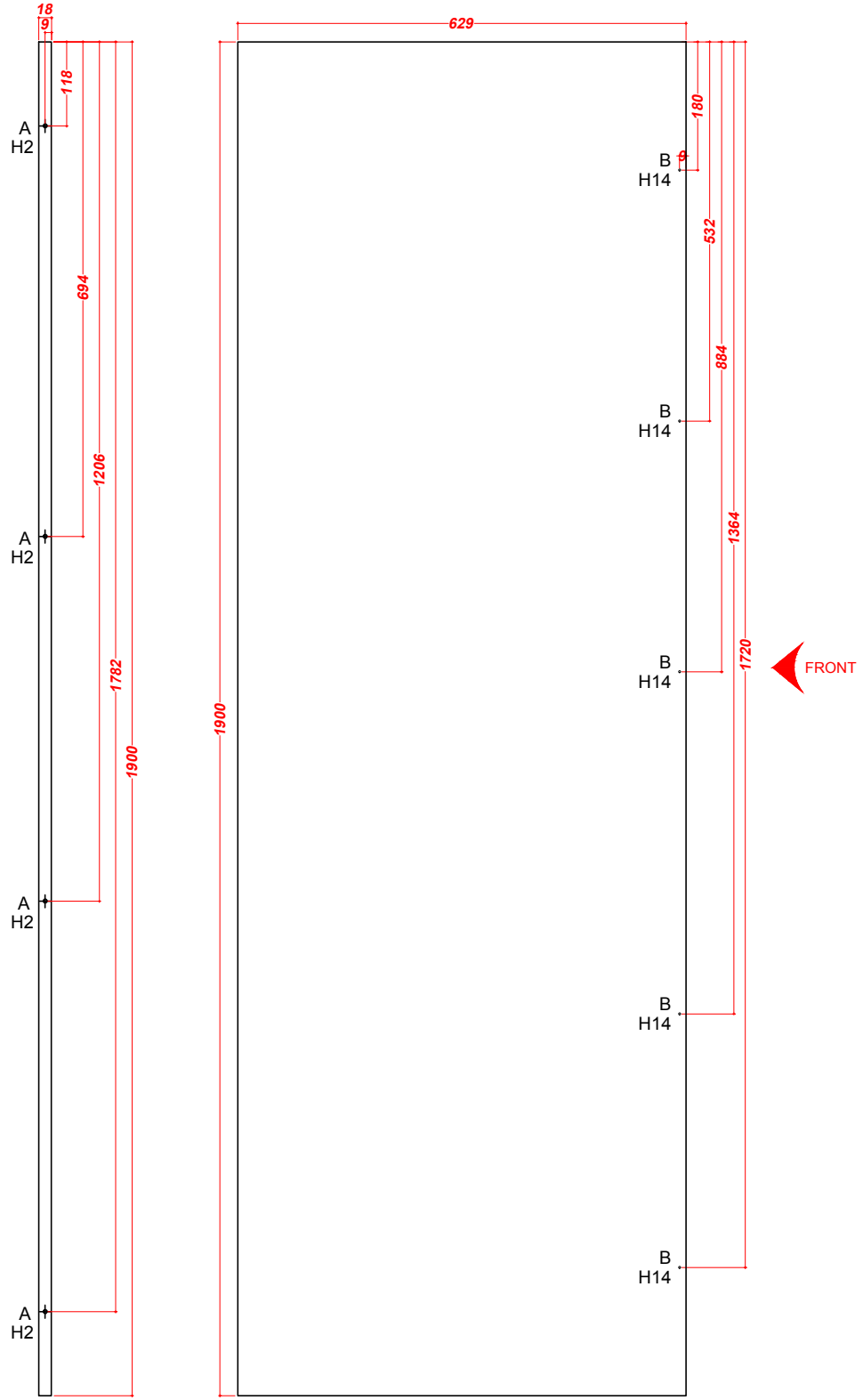
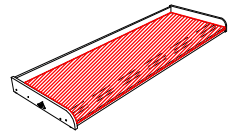

BOTH ENDS
AMBOS EXTREMOS

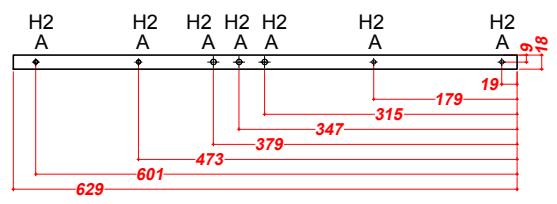

Part: Desk Top (15)
Material: MDF
Thick: 18mm
Quantity: 1

SCREW HEADS

PERFORATION

A	5.5	70
B	3	2



CONFIDENTIAL DRAWINGS
ALL REPRODUCTION PROHIBITED

Mecanismo London

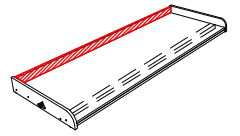

Part: Desk Back (16)
 Material: MDF
 Thick: 18mm
 Quantity: 1

SCREW HEADS	
H2	4

PERFORATION		
A	7	PASS

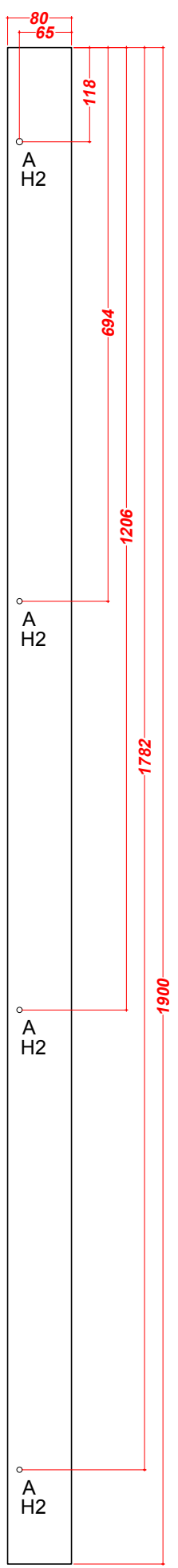

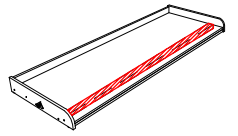

25 50

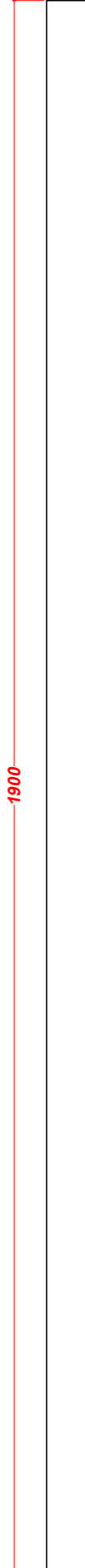

Part:Desk Stiffener (17)

Material: STEEL

Thick: 25x25x1.6

Quantity: 1

SCREW HEADS

PERFORATION



CONFIDENTIAL DRAWINGS
ALL REPRODUCTION PROHIBITED

Mecanismo London

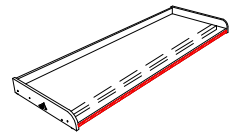

Part: Tube Cover (18)

Material: MDF

Thick: 18mm

Quantity: 1

SCREW HEADS

H14	5
-----	---

PERFORATION

A	5	PASS
---	---	------

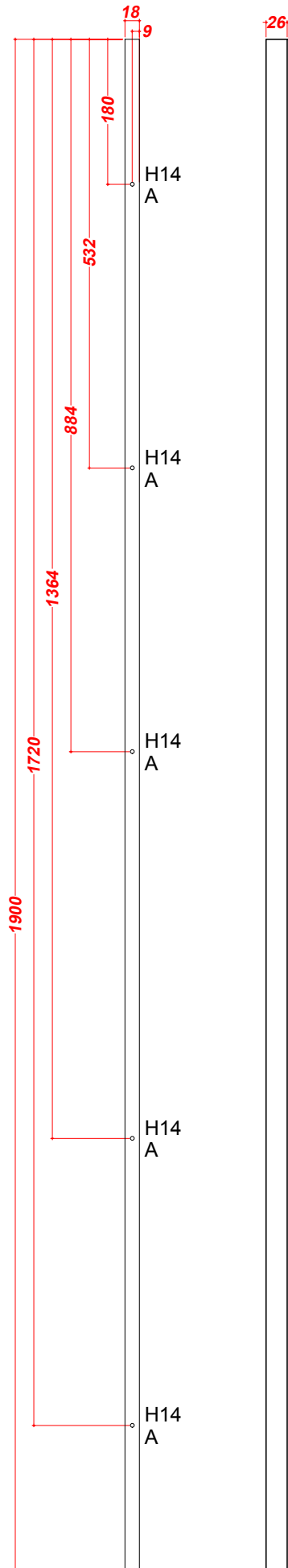

CONFIDENTIAL DRAWINGS
ALL REPRODUCTION PROHIBITED

Mecanismo London

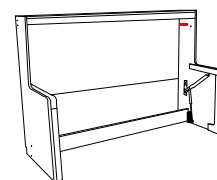

Part: Bed Stop (19)

Material: MDF

Thick: 18mm

Quantity: 2

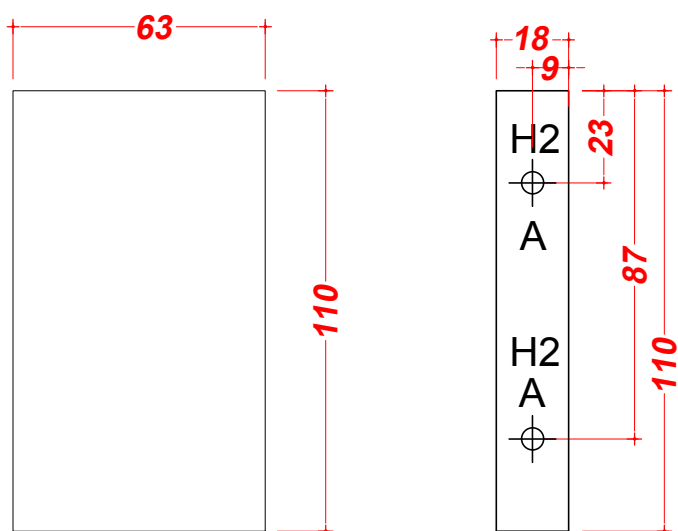

SCREW HEADS

PERFORATION

A	5.5	52



CONFIDENTIAL DRAWINGS
ALL REPRODUCTION PROHIBITED

Mecanismo London

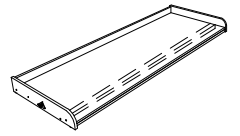

Part: WP Plug (20)

Material: MDF

Thick: 18mm

Quantity: 2

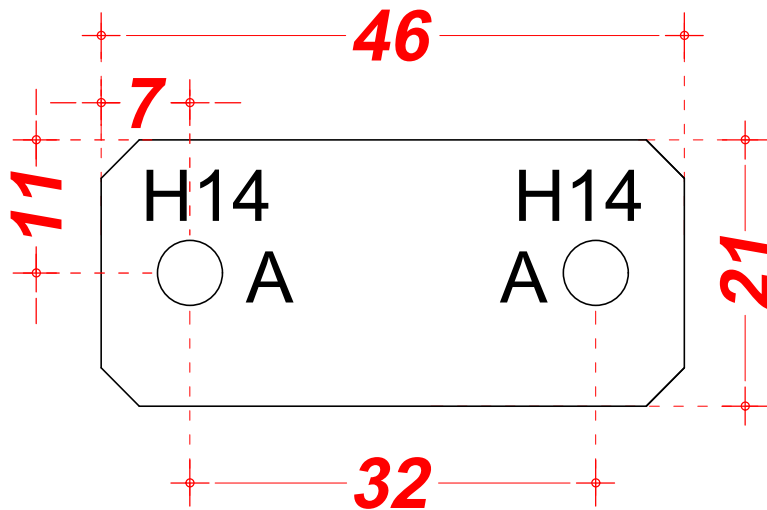

SCREW HEADS

H14 2 x 2

PERFORATION

A	5	PASS



CONFIDENTIAL DRAWINGS
ALL REPRODUCTION PROHIBITED

Mecanismo London
TD 06 SP 1000 x 1900 CQU

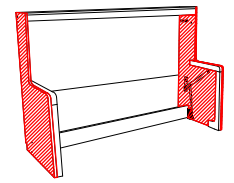

Part: Body Side (1)

Material: MDF

Thick: 18mm

Quantity: 2

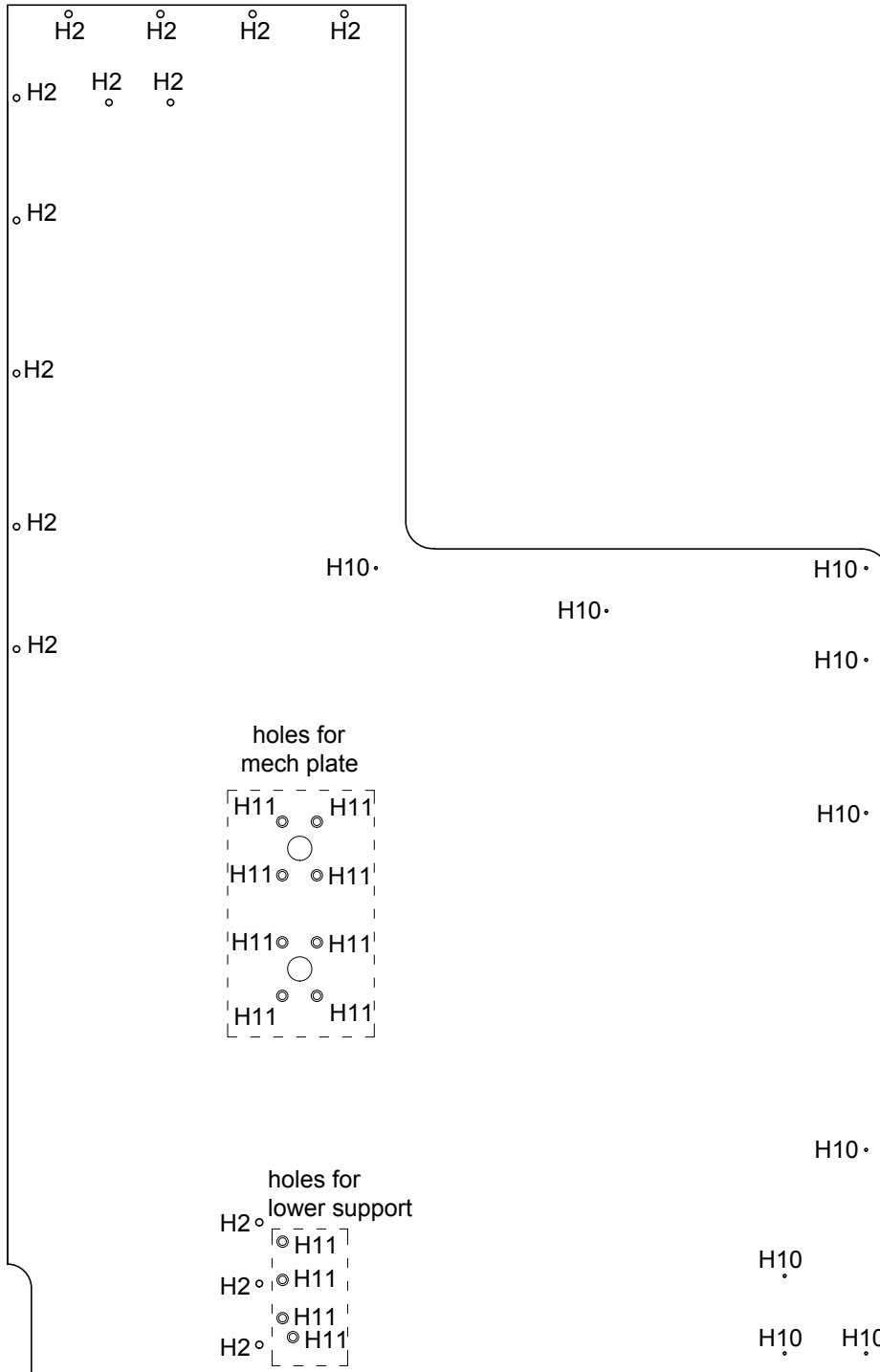

SCREW HEADS

H2 14 x 2

H11 12 x 2

PERFORATION



CONFIDENTIAL DRAWINGS
ALL REPRODUCTION PROHIBITED

Date: 03/10/2018