











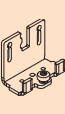

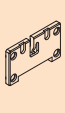



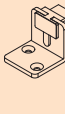

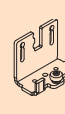

Garnituren / Sets / Garnitures

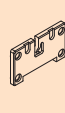
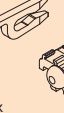
| 19 MM TÜRSÄRKE 25 MM TÜRSÄRKE | |
|--|--|
| 2 Türen Doors Portes | 19mm 055.3120.072 25mm 055.3120.071 |
|  2x |  2x |
|  2x |  2x |
|  4x |  2x  4x |
|  4x |  1x |
|  4x | |

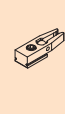
| 19 MM TÜRSÄRKE 25 MM TÜRSÄRKE | |
|--|--|
| 3 Türen Doors Portes | 19mm 055.3120.074 25mm 055.3120.073 |
|  2x |  4x |
|  4x |  2x |
|  6x |  3x  4x |
|  4x |  2x |
|  3x |  4x |

Zubehör / Accessories / Accessoires

Doppelführungsschiene Alu, gelocht

Double guide track, aluminium, pre-drilled
Rail de guidage double en alu, perforé

Gr./Size

Art. No.

| | |
|---------|--------------|
| 2500 mm | 056.3072.250 |
| 3500 mm | 056.3072.350 |
| 6000 mm | 056.3072.600 |

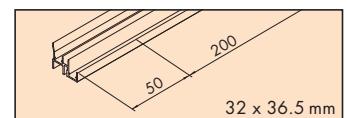

Doppelaufschiene Alu, eloxiert, gelocht

Double running track, aluminium, anodized, pre-drilled
Rail de roulement double en alu, anodisé, perforé

| | |
|---------|--------------|
| 2500 mm | 055.3100.250 |
| 3500 mm | 055.3100.350 |
| 6000 mm | 055.3100.600 |

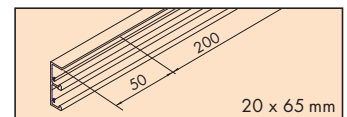

Abdeckprofil, Alu, eloxiert, oben/unten

Cover profile, aluminium, anodized, top/bottom
Profil de recouvrement, en alu, anodisé, haut/bas

| | |
|---------|--------------|
| 2500 mm | 055.3130.250 |
| 3500 mm | 055.3130.350 |
| 6000 mm | 055.3130.600 |

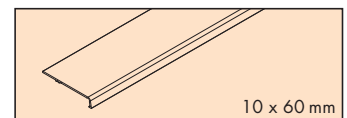

Zwischenstopper

Intermediate stop
La butée intermédiaire

055.3128.071

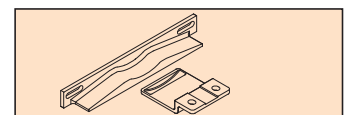

A

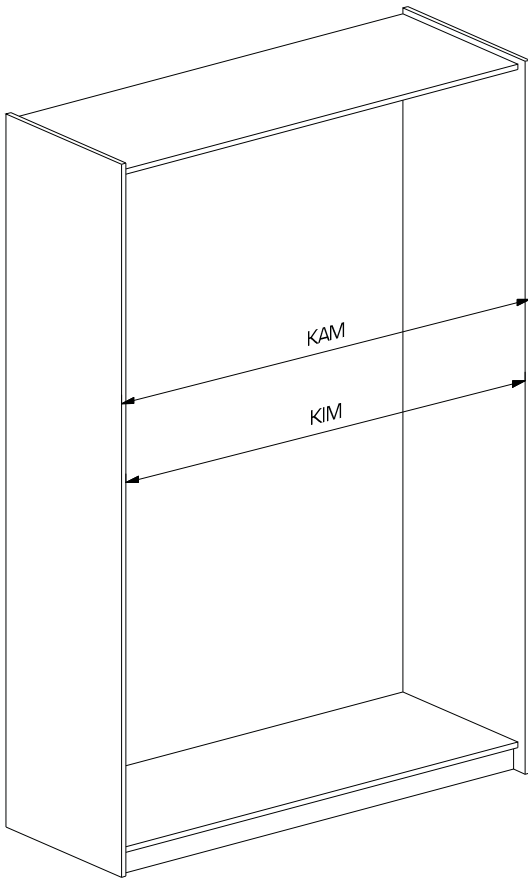

B

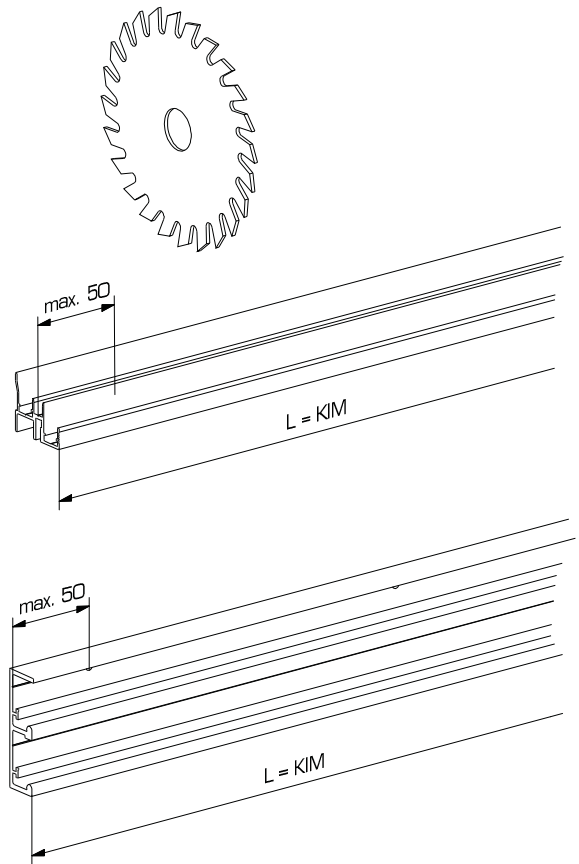

C 2 Türen / 2 doors / 2 portes: 2x: (1x li / 1x re)
3 Türen / 3 doors / 3 portes: 3x: (1x li / 2x re)

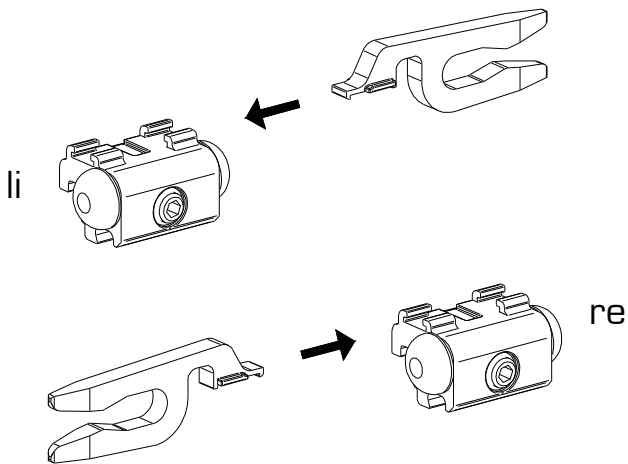

D

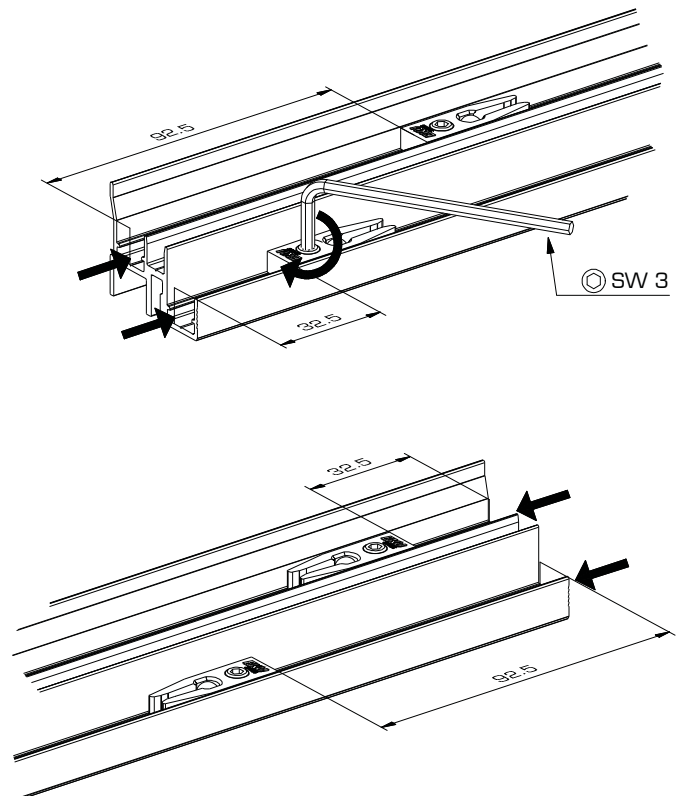

0 x

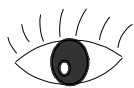
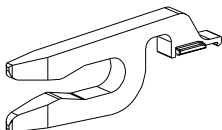

siehe Seite 3, 4, 6
see Side 3, 4, 6
voir côté 3, 4, 6

li: links / left / gauche
re: rechts / right / droite

E

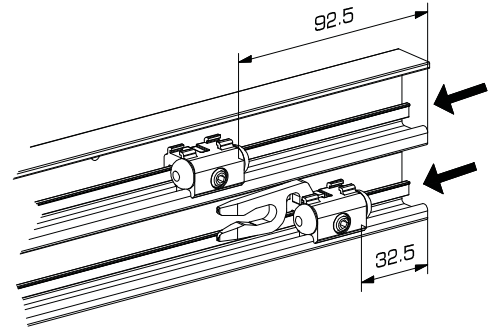
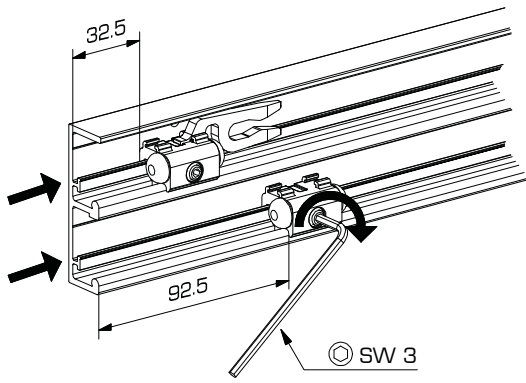

F

Art.No. 055.3042.072
Art.No. 055.3129.071



PZ No.2
⊕ ⊕ Ø 5 x 30

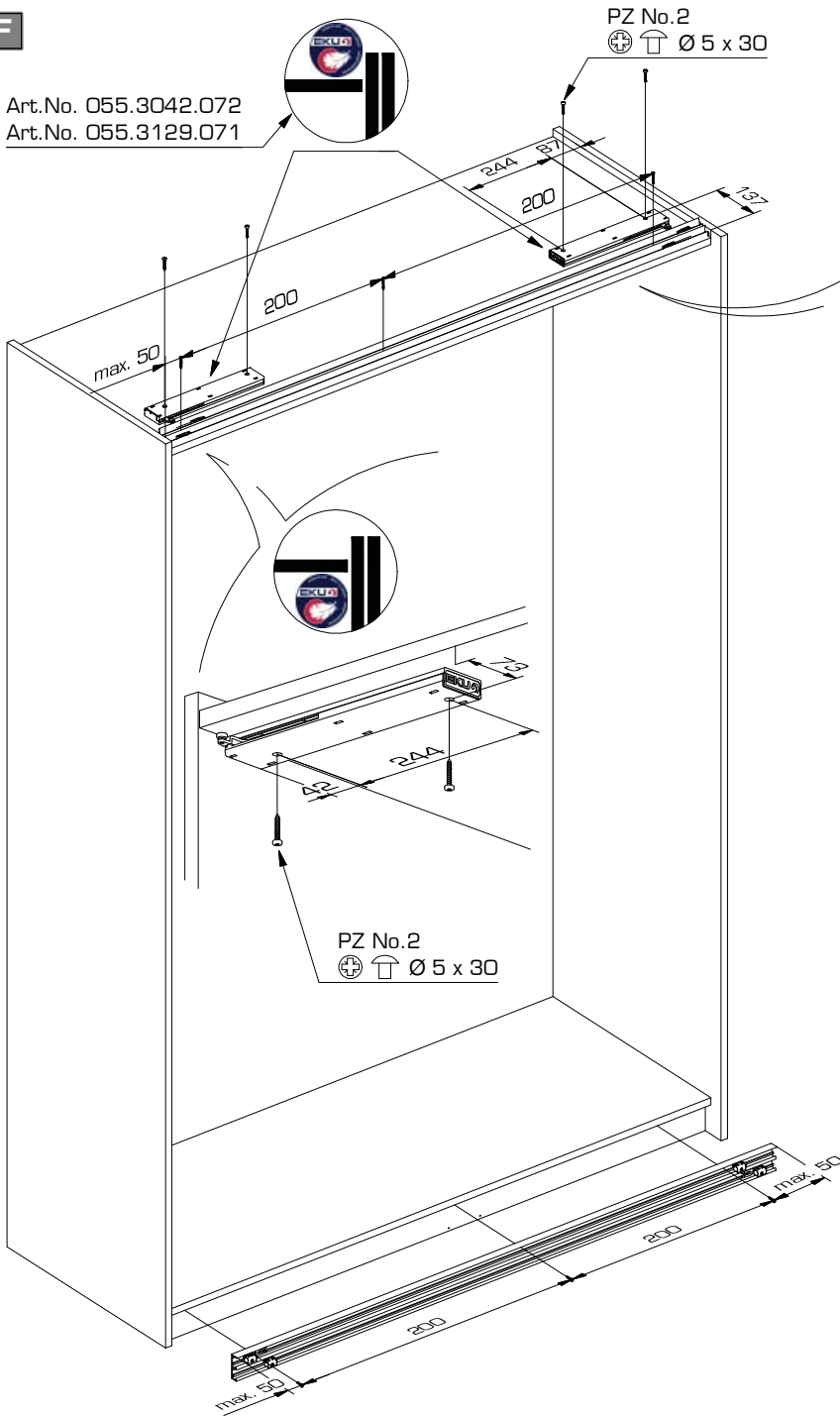

PZ No.2
⊕ ⊕ Ø 5 x 30

Art.No. 055.3042.071



43 (Tür/door/porte 19mm)
37 (Tür/door/porte 25mm)

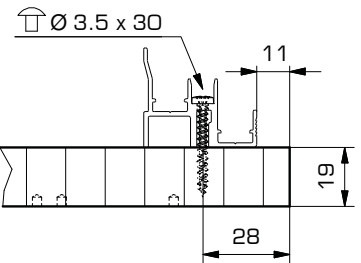
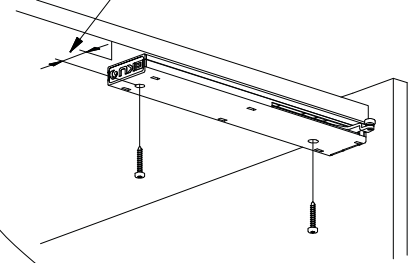

optional
optional
optionnel

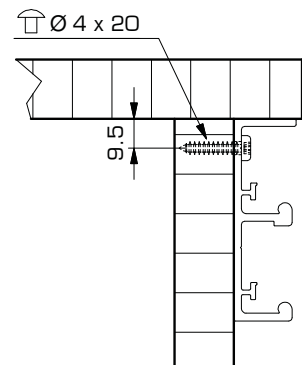
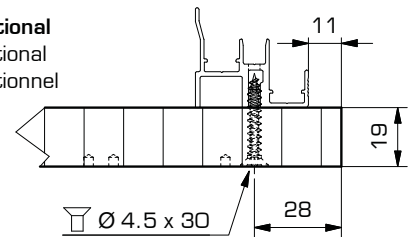

G



TX 20
 \oplus \uparrow \varnothing M4 x 8

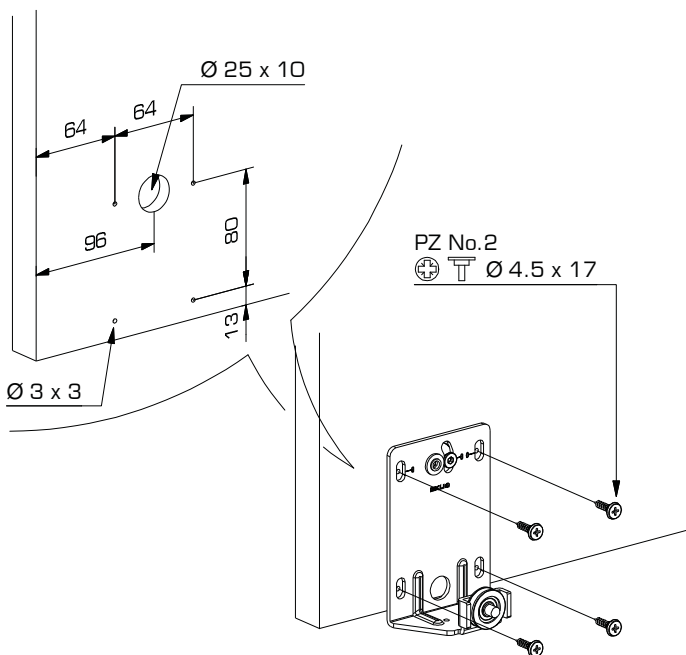
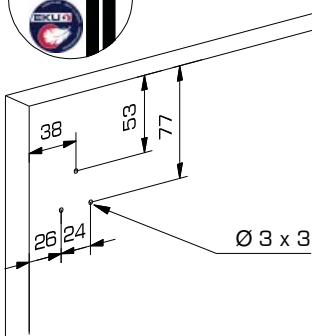
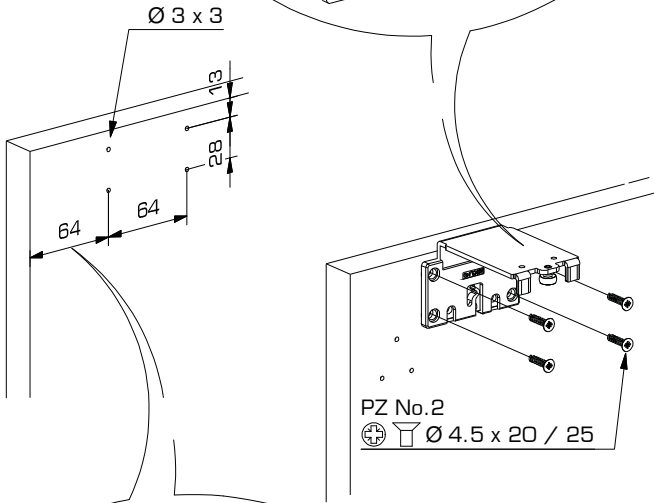
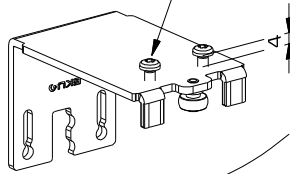

TX 20
 \oplus \uparrow \varnothing M4 x 8

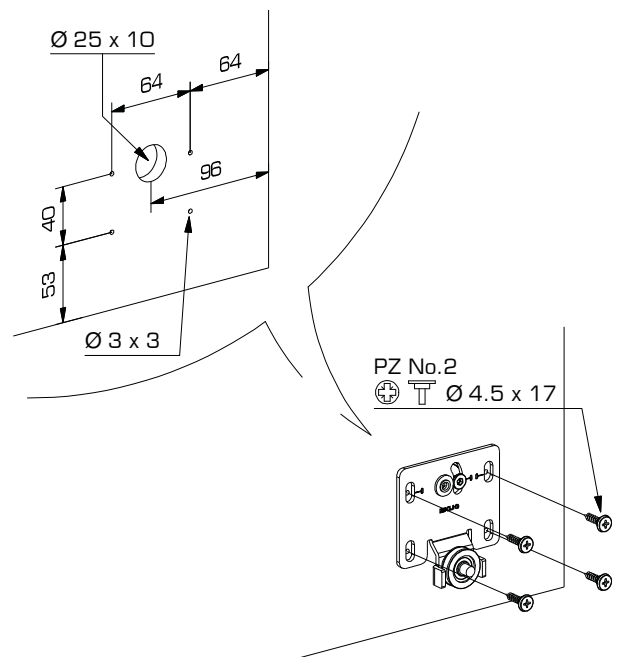
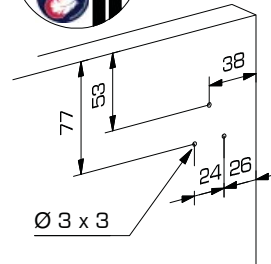
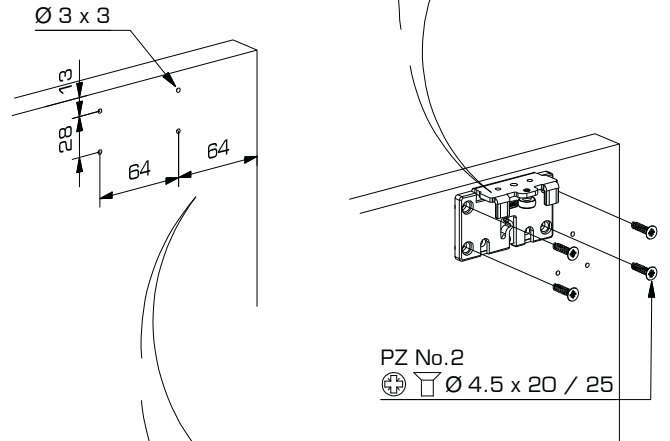
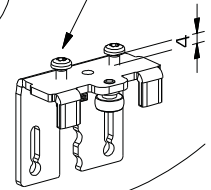

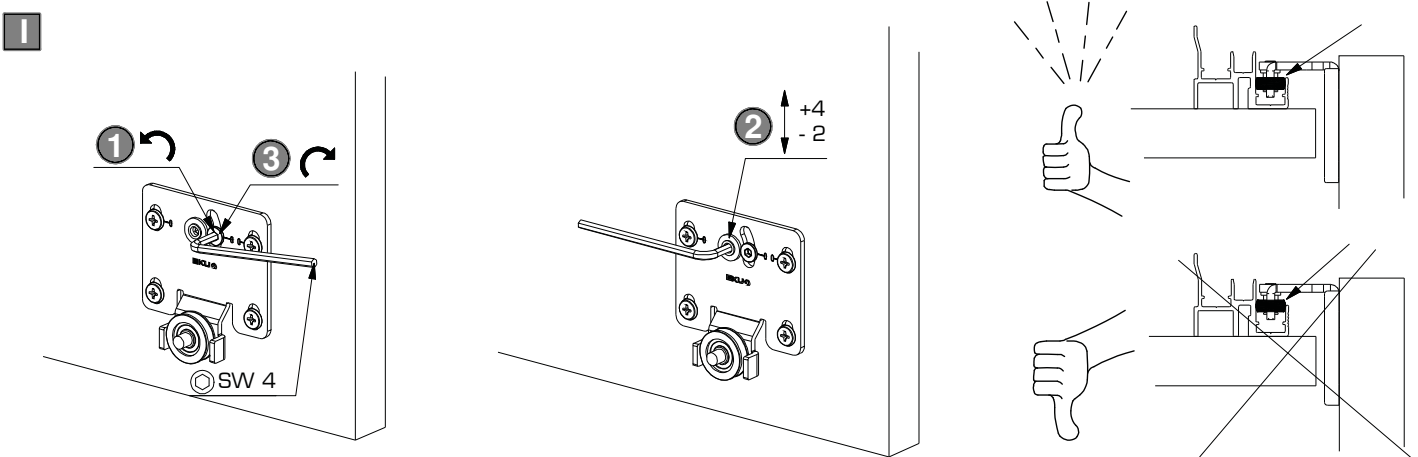
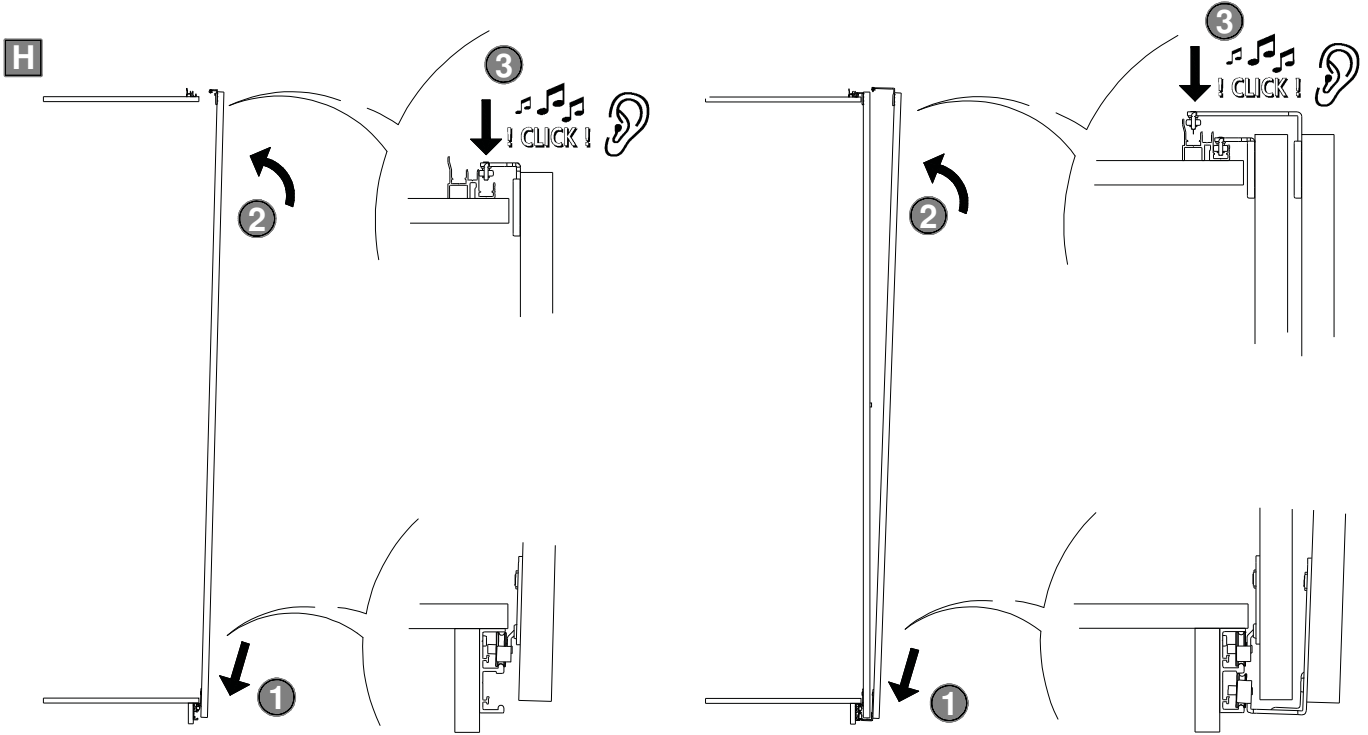

J 2 Türen / 2 doors / 2 portes

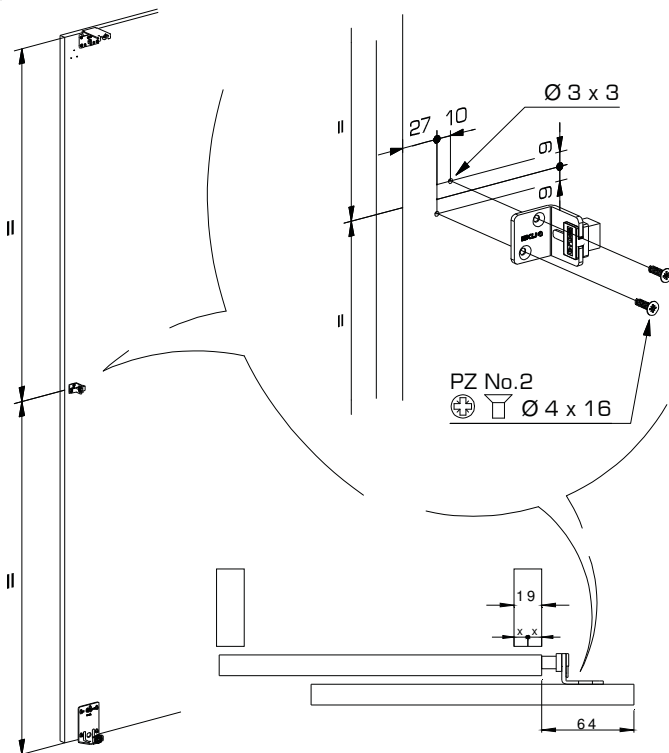

K 3 Türen / 3 doors / 3 portes

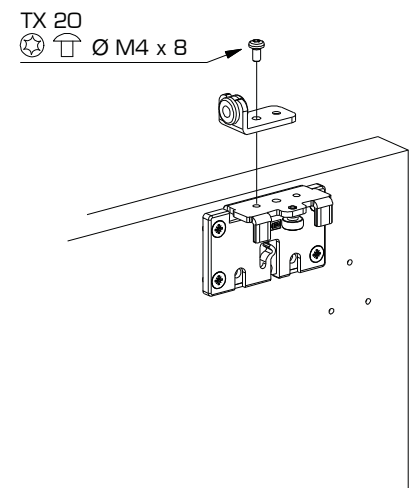

L

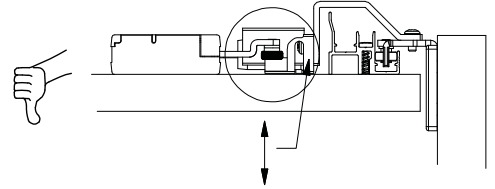
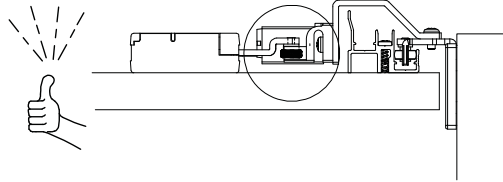

3 TX 20
 Ø M4 x 8

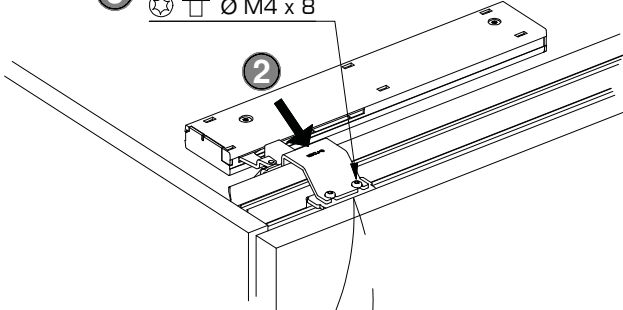

3 TX 20
 Ø M4 x 8

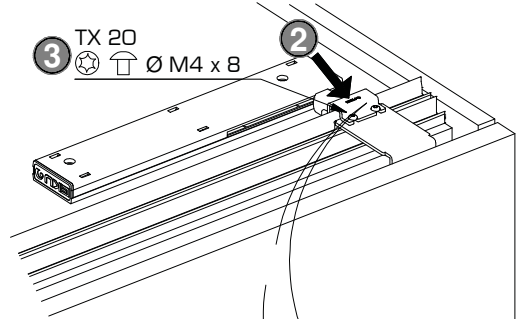

1 PZ No.2
 Ø M4 x 8

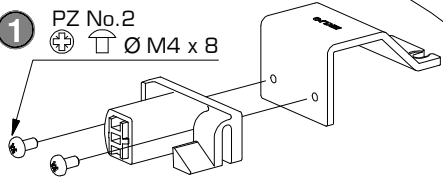

1 PZ No.2
 Ø M4 x 8

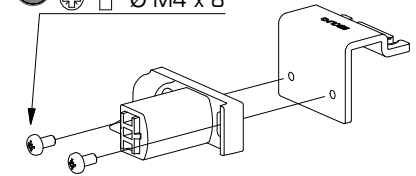

M Optional / optional / optionnel

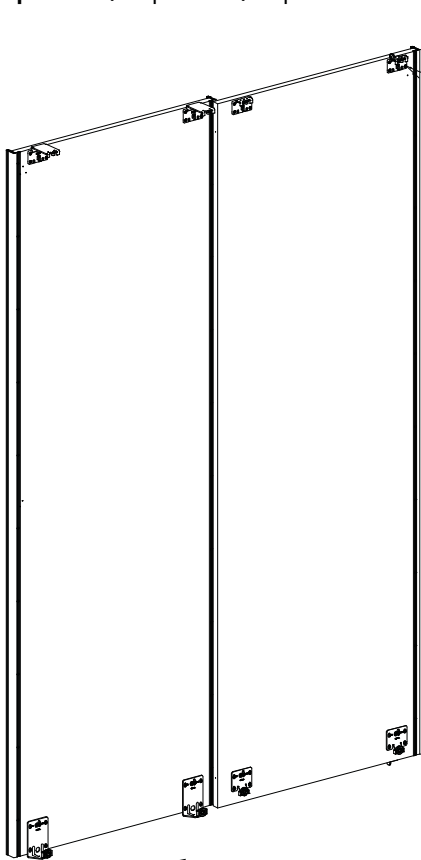

PZ No.2
 Ø 4 x 16

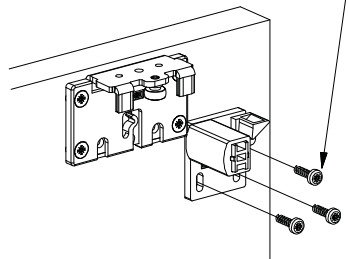

Art.No. 055.3060 Ø 3 x 16

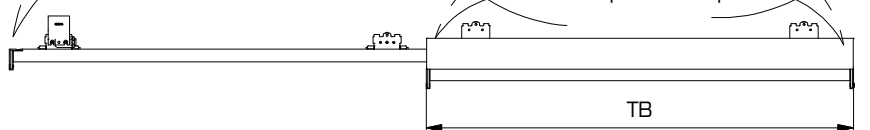
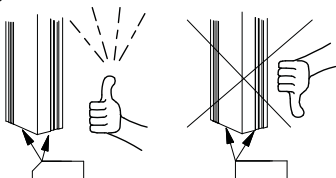
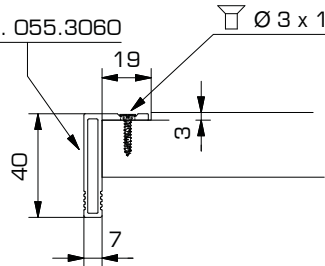

N Optional / optional / optionnel

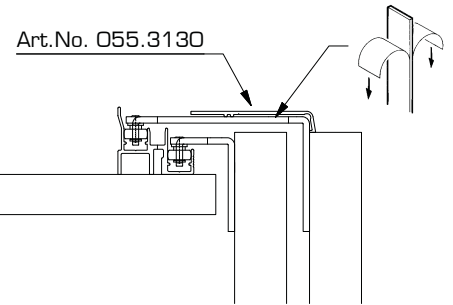

3 Türen / 2 Türen mit Dämpfung
 3 doors / 2 doors with soft closing
 3 portes / 2 portes avec amortissement

Art.No. 055.3130

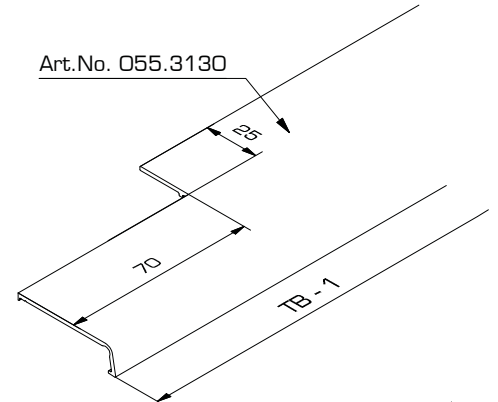

beidseitig nur bei 3 Türen
 bilateral only when 3 doors
 bilatéral que avec 3 portes

O 3 Türen / 3 doors / 3 portes

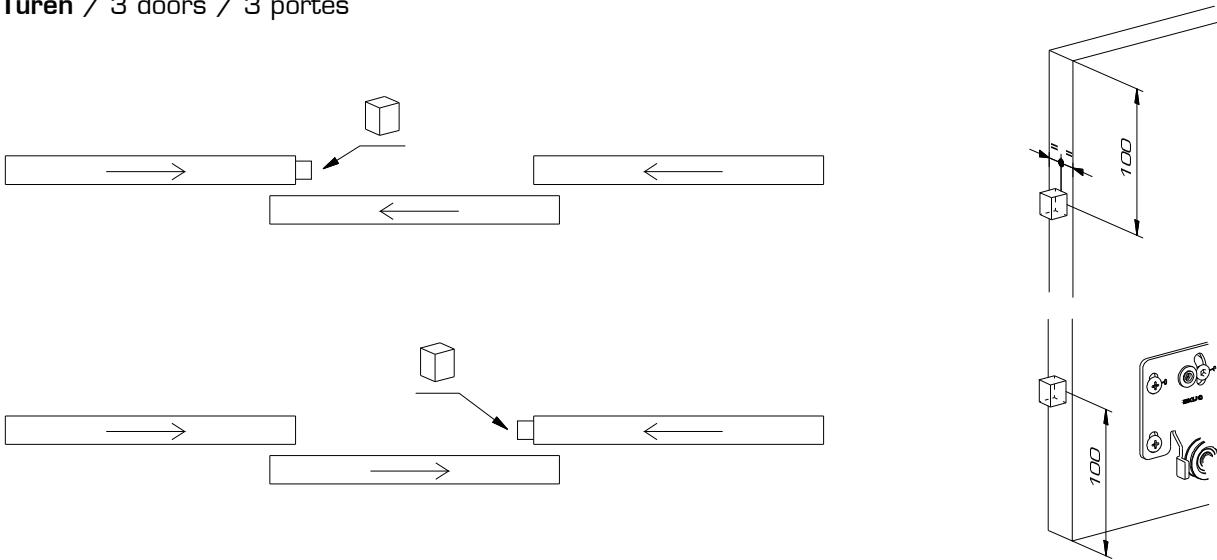

P 3 Türen / 3 doors / 3 portes
Optional / optional / optionnel

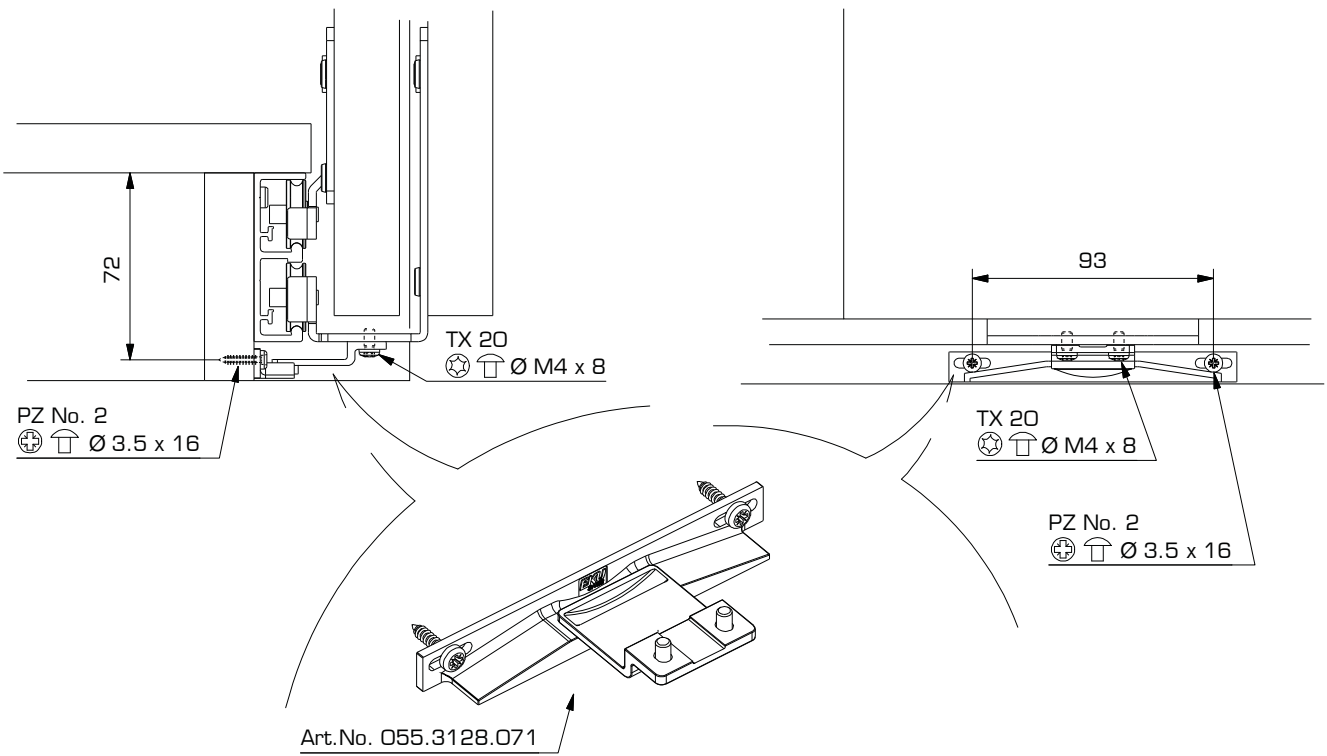

Einbaubeispiele / Mounting examples / Exemples de montage

