

! CLOSE THE DOOR SLOWLY AT FIRST AUTOMATIC LOAD AFTER INSTALLATION

CHIUDERE LA PORTA LENTAMENTE AL PRIMO CARICAMENTO AUTOMATICO DOPO L'INSTALLAZIONE

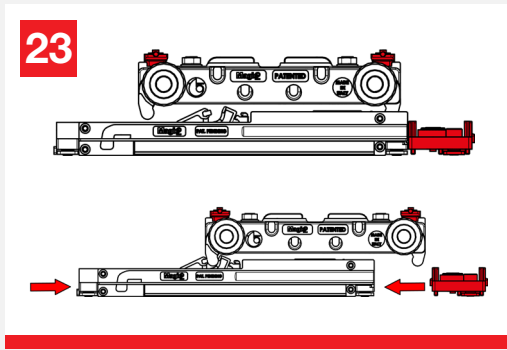

! IN ORDER TO ADJUST DOOR POSITIONING IT IS POSSIBLE TO MOVE THE DAMPER

PER REGOLARE LA POSIZIONE DELLA PORTA E' POSSIBILE SPOSTARE L'AMMORTIZZATORE

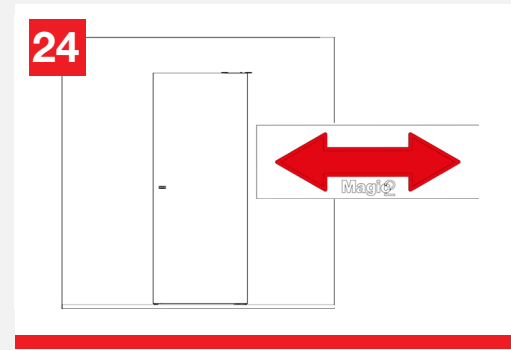

! RECOMMENDED FOR APPLICATIONS IN PUBLIC SPACES, HOTELS AND RESIDENCES

RACCOMANDATO L'UTILIZZO PER APPLICAZIONI IN SPAZI PUBBLICI, HOTEL E RESIDENCE

ACCESSORIES PLACEMENT (STANDARD POSITION) / POSIZIONAMENTO DEGLI ACCESSORI (POSIZIONE STANDARD)

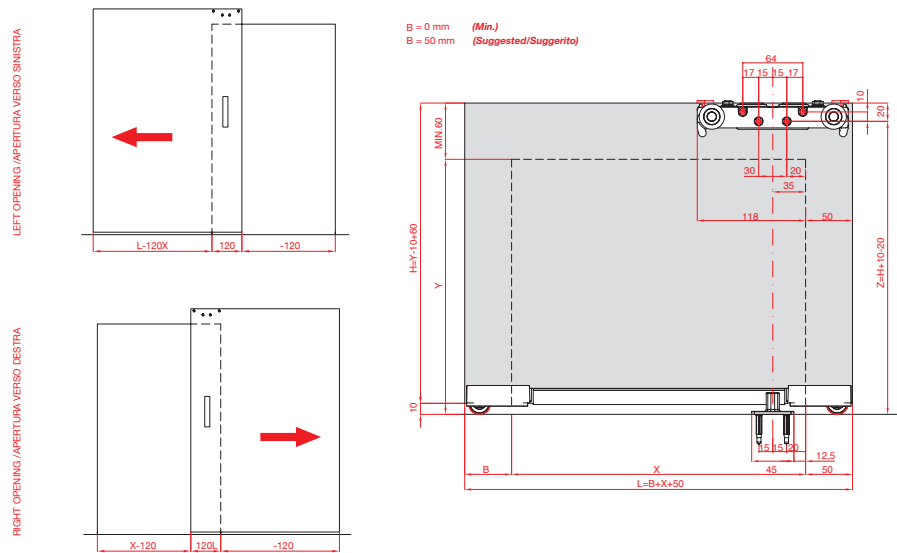

MAGIC2/1800 (K.0031.2.01)

B=0
X= MIN. 800 (L=850)
X= MAX. 1750 (L=1800)

B=50
X= MIN. 800 (L=900)
X= MAX. 1700 (L=1800)

ACCESSORIES PLACEMENT (TOTAL OPENING POSITION) / POSIZIONAMENTO DEGLI ACCESSORI (POSIZIONE APERTURA TOTALE)

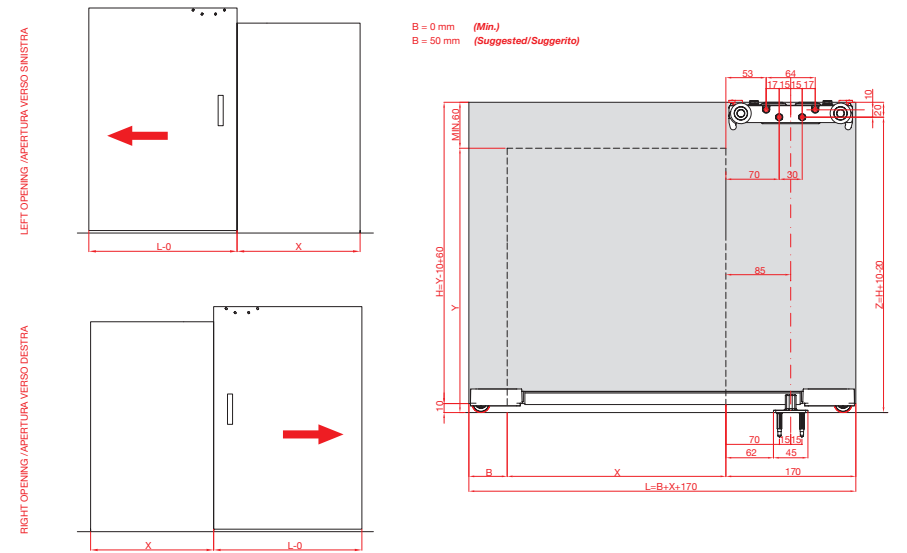

MAGIC2/1800 (K.0031.2.01)

B=0
X= MIN. 680 (L=850)
X= MAX. 1630 (L=1800)

B=50
X= MIN. 680 (L=900)
X= MAX. 1580 (L=1800)

ACCESSORIES PLACEMENT (INTERMEDIATE POSITION) / POSIZIONAMENTO DEGLI ACCESSORI (POSIZIONE INTERMEDIA)

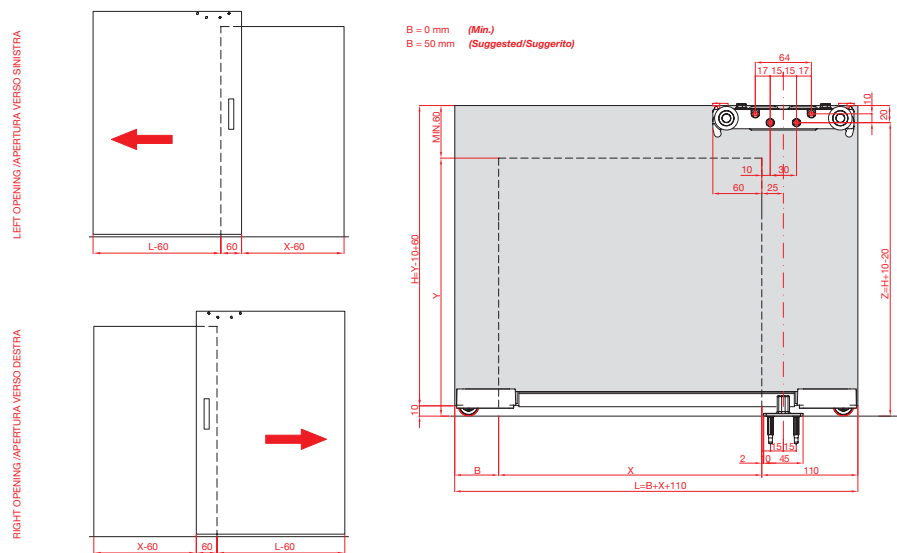

MAGIC2/1800 (K.0031.2.01)

B=0
X= MIN. 740 (L=850)
X= MAX. 1690 (L=1800)

B=50
X= MIN. 740 (L=900)
X= MAX. 1640 (L=1800)

MEASUREMENTS DESCRIPTION / DESCRIZIONE MISURE

