

[ITA] **Tipologia di montaggio**  
1 ANTA

[ENG] **Types of assembly**  
1 DOOR

[ESP] **tipos de montaje**  
1 PUERTA

[DEU] **Montageart**  
1 TÜR

[POR] **Tipologia de montagem**  
1 PORTA

[FRA] **Types de montage**  
1 PORTE

[ZH] **安装类型**  
1 门

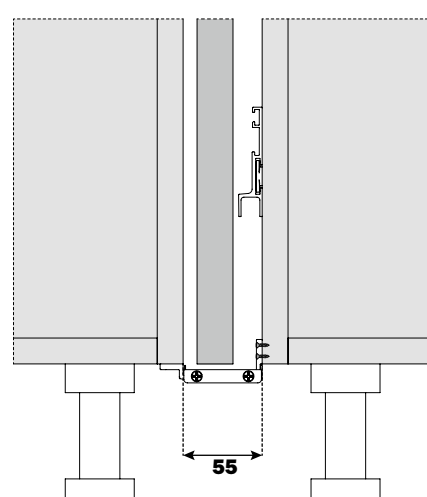
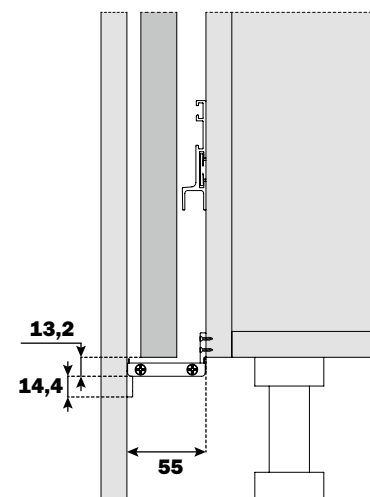
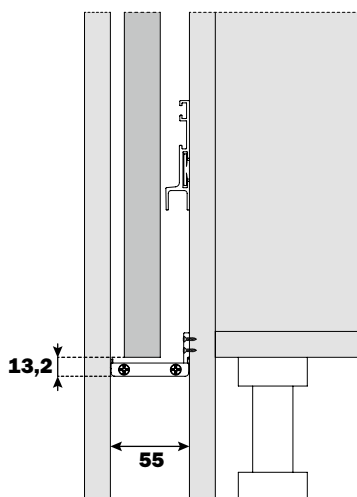
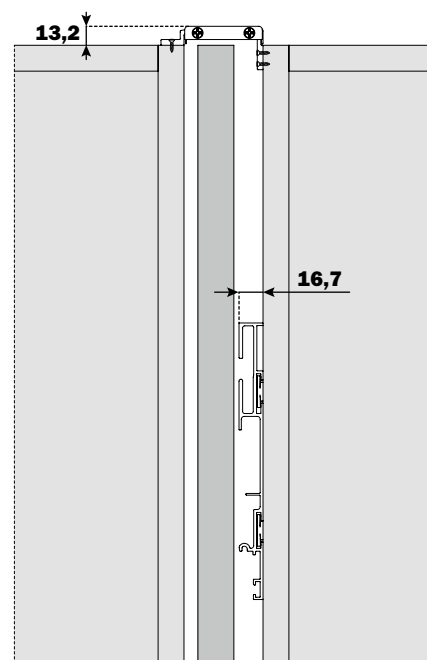
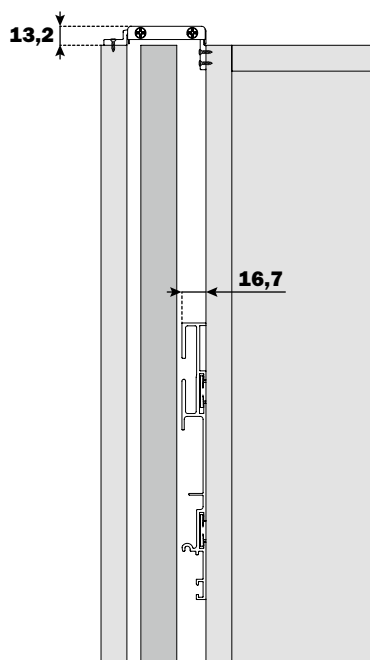
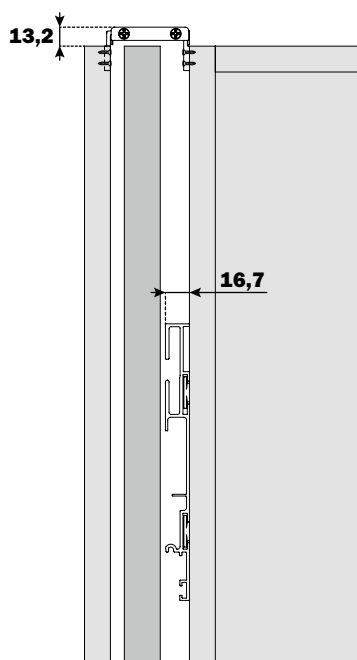



[ITA] **Tipologia di montaggio**  
2 ANTE

[ENG] **Types of assembly**  
2 DOORS

[ESP] **Tipos de montaje**  
2 PUERTAS

[DEU] **Montageart**  
2 TÜREN

[POR] **Tipologia de montagem**  
2 PORTAS

[FRA] **Types de montage**  
2 PORTES

[ZH] **安装类型**  
2 门

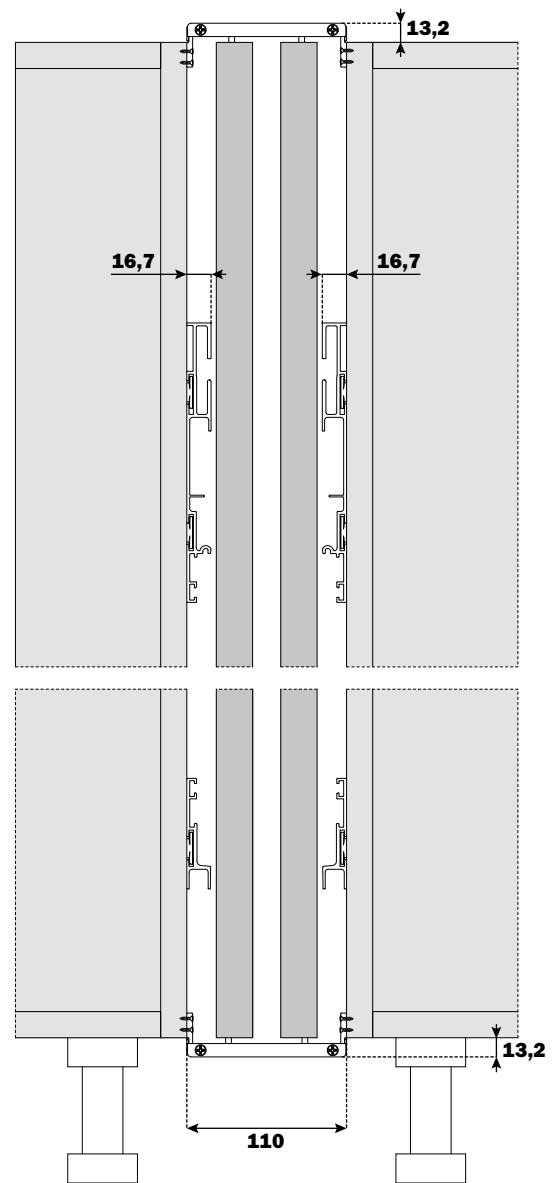
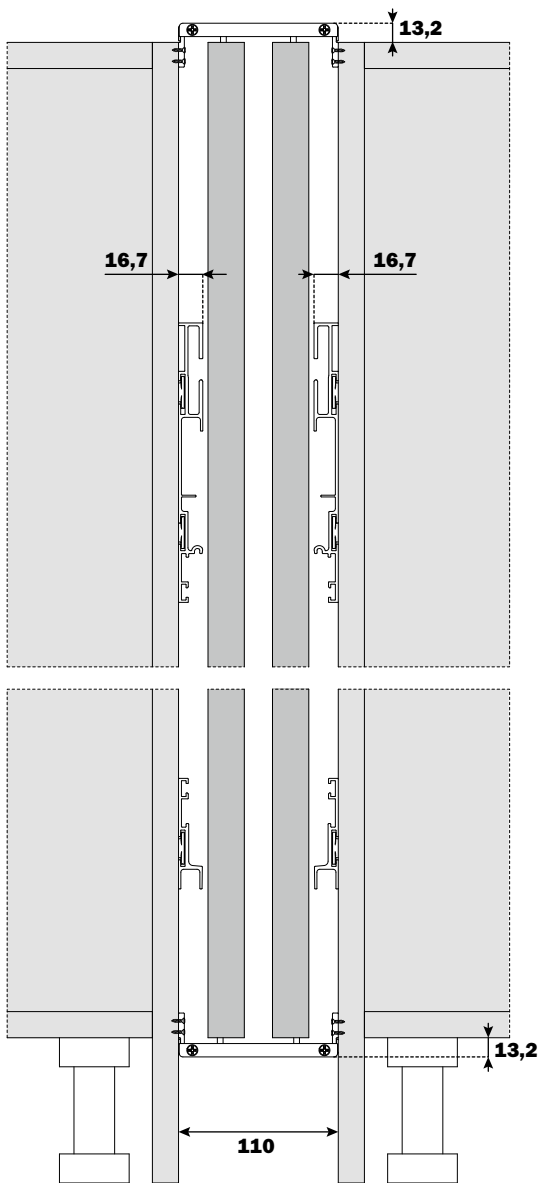

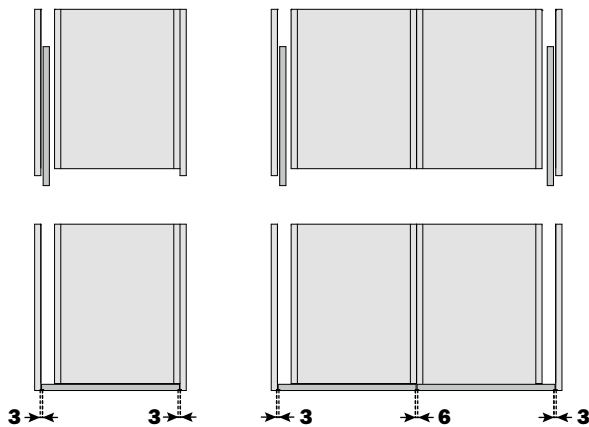
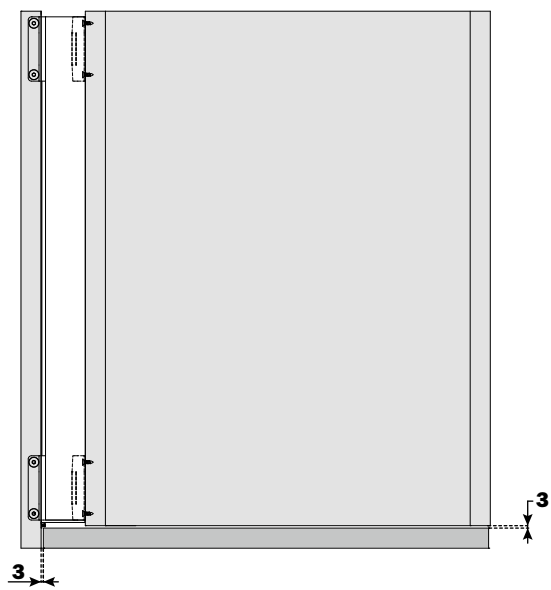
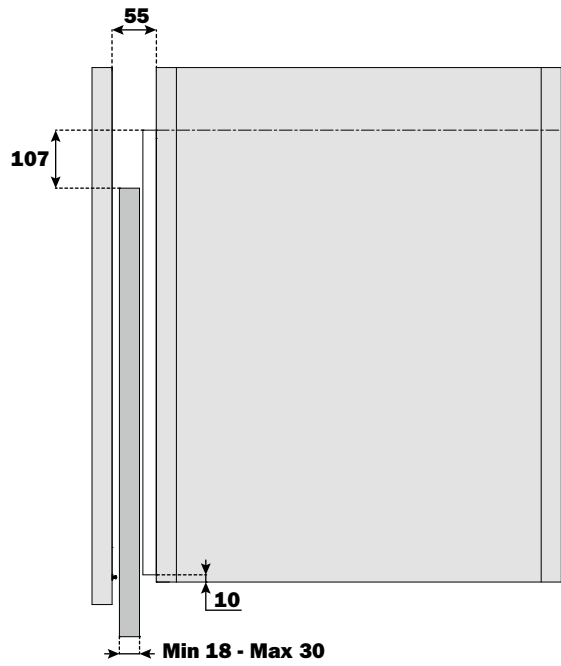

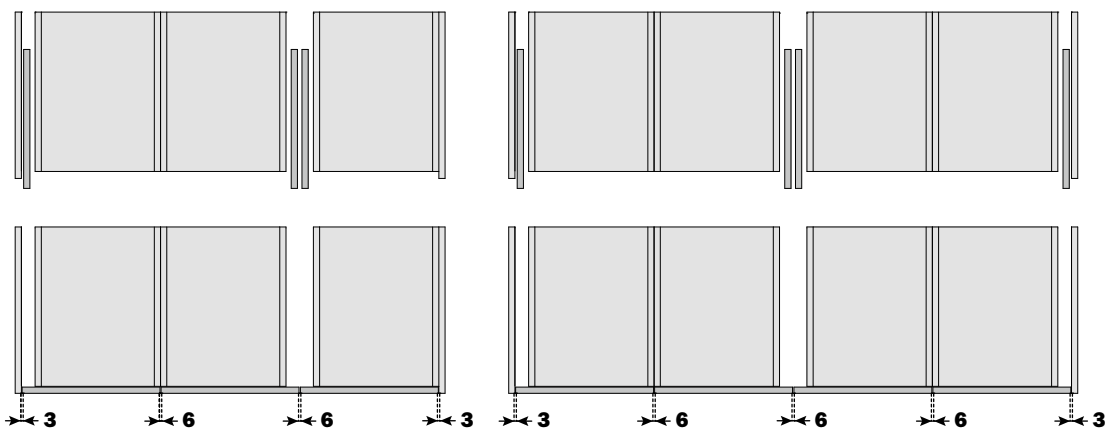
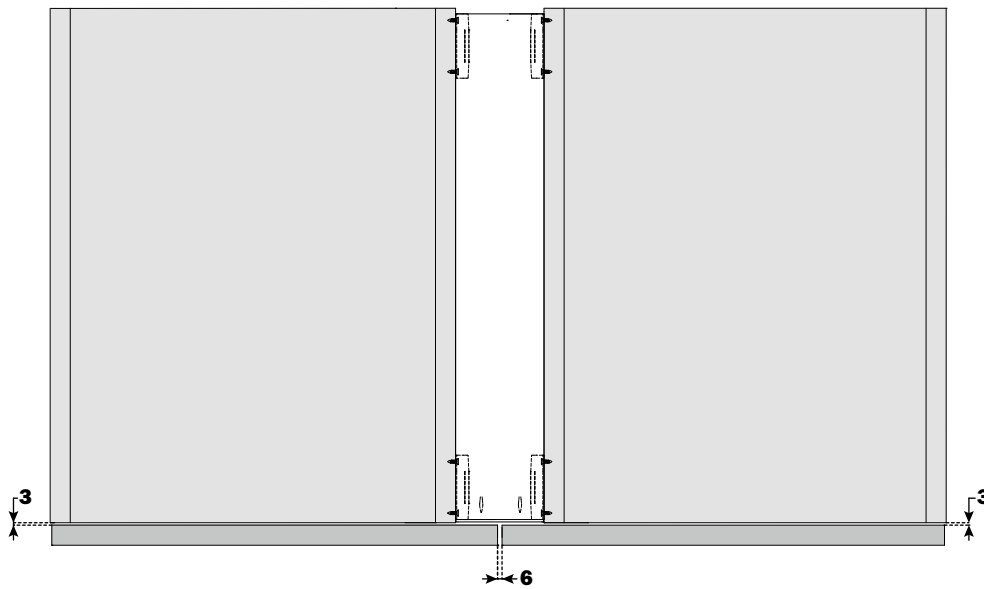
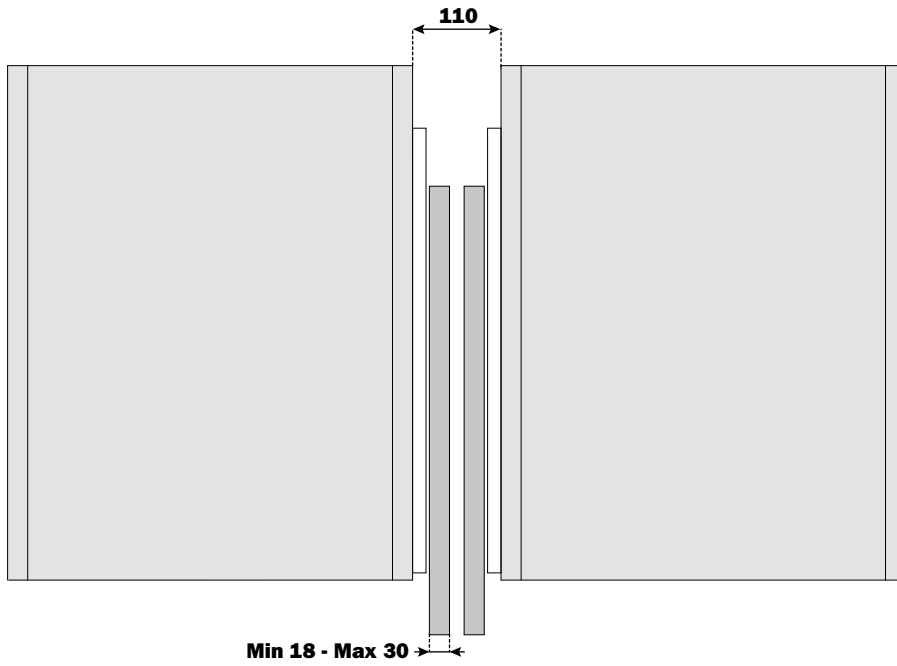

[ITA] **Calcolo del valore LPU**  
**Scelta della camma**

[ENG] **Calculating the LPU value**  
**Selecting the cam connectors**

[ESP] **Cálculo del valor LPU**  
**Elección de la leva (cam)**

[DEU] **Berechnung Des Wertes LPU**  
**Auswahl Des Nocken (Cam)**

[POR] **cálculo do valor LPU**  
**escolha do cam**

[FRA] **Calcul de la valeur LPU**  
**Choix de la came**

[ZH] **计算 LPU, 选择凸轮连接片**

$LPS^* \geq TL$    $LPU^{**} = TL$

**LPS\*** = Profondità struttura  
Cabinet depth  
Schranktiefe  
Profondeur de la structure  
Structure Profondeur  
Profundidade da estrutura  
柜体深度

**LPU\*\*** = Profondità struttura utile  
Usable cabinet depth  
Nutzbare Schranktiefe  
Profundidad de estructura útil  
Estructura de profundidad útil  
Profundidade útil da estrutura  
系统深度 (有效柜体深度)

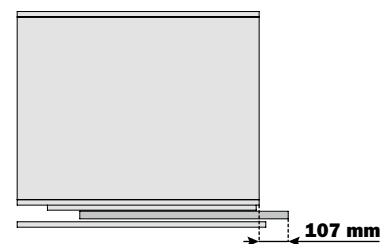
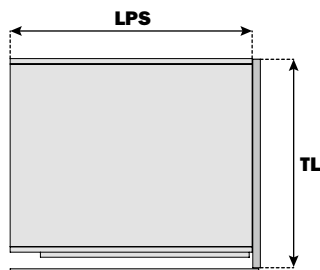
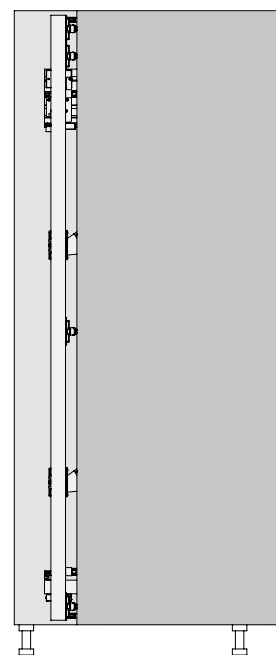
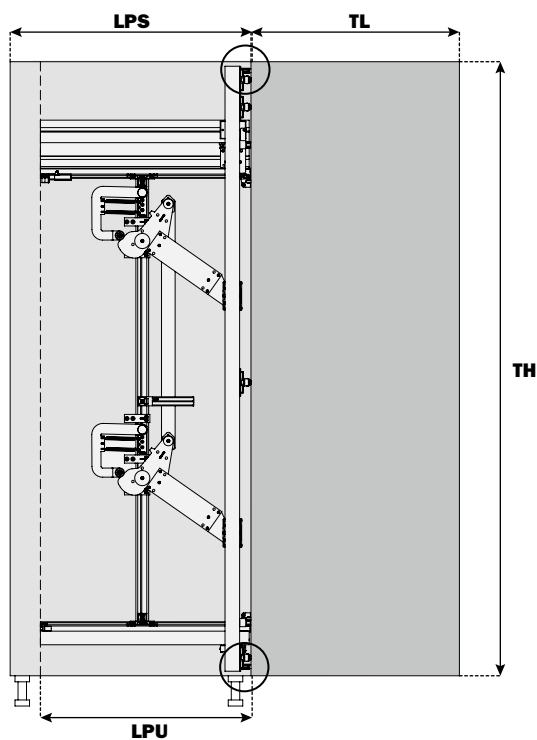
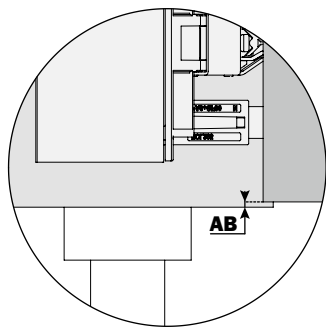
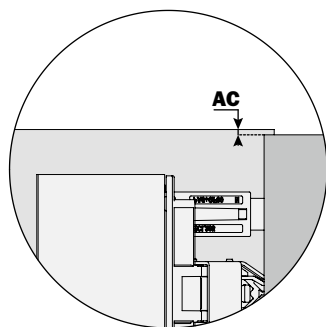



LPS < TL



LPU = LPS

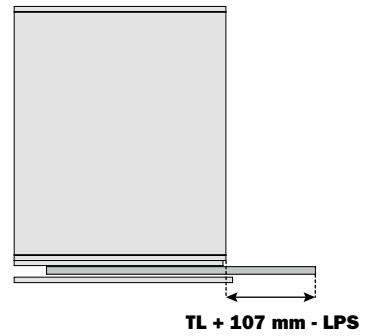
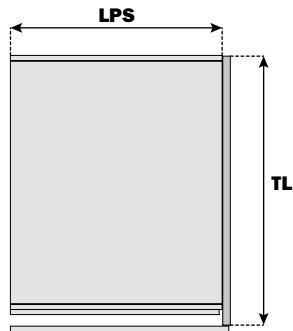
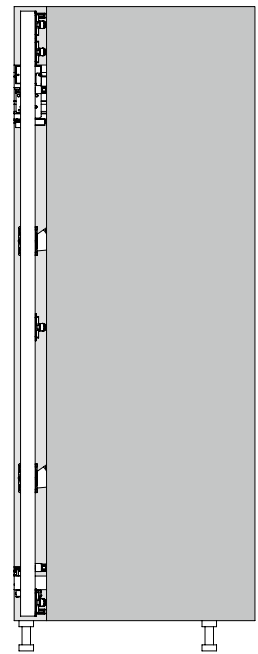
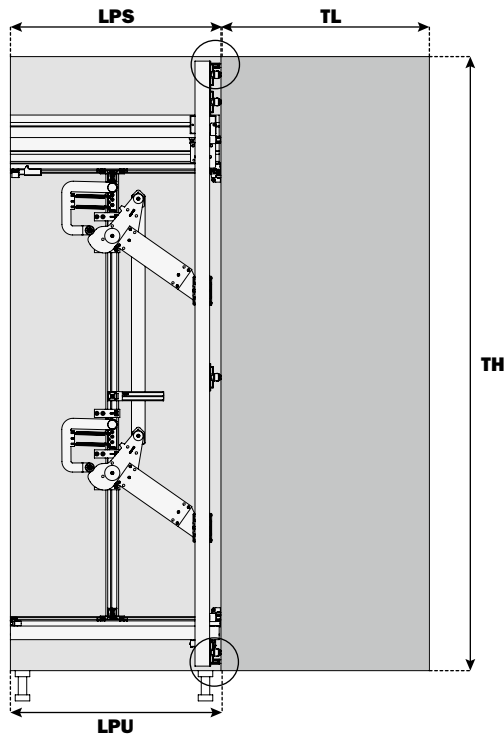
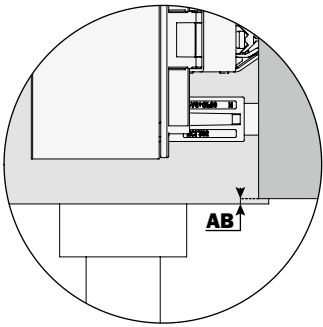
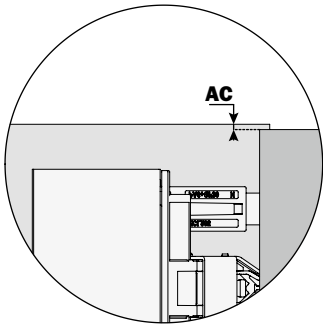

[ITA] **Calcolo della sporgenza con anta aperta**

[ENG] **Calculating the door protrusion from the cabinet**

[ESP] **Cálculo del saliente de la puerta con puerta abierta**

[DEU] **Berechnung Des Türvorsprungs Bei Geöffneter Tür**

[POR] **Cálculo do avanço com a porta aberta**

[FRA] **Calcul de la sortie de la porte avec la porte en position ouverte**

[ZH] **计算门板突出柜体的距离**

**LPS ≥ TL**

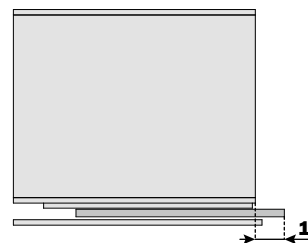
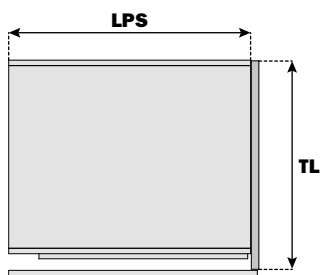
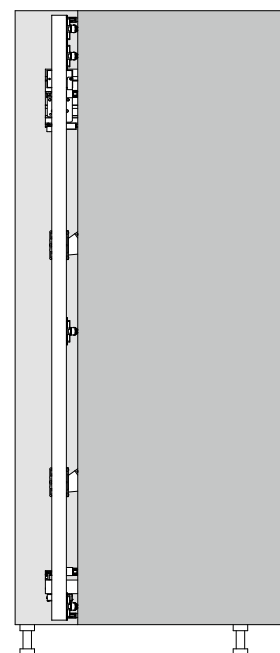
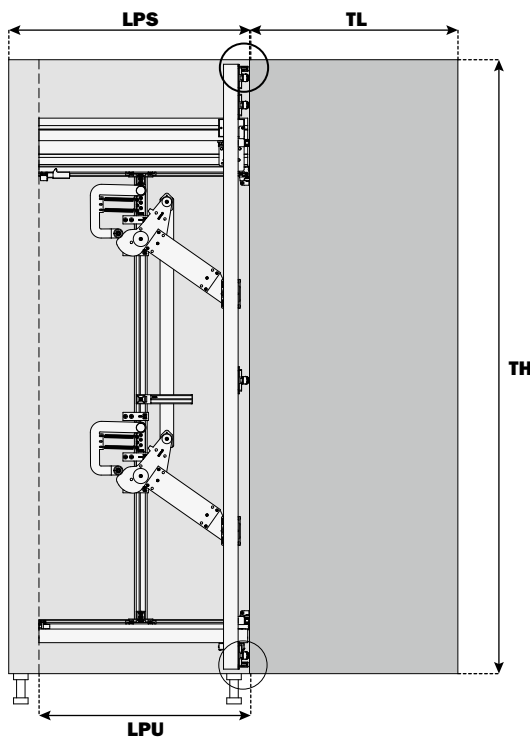
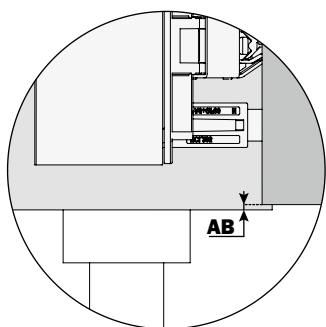
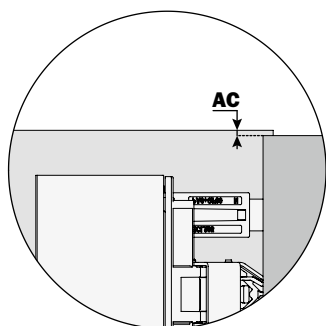

ESEMPIO  
EXAMPLE  
BEISPIEL  
EXEMPLE  
EJEMPLO  
EXEMPLO  
示例

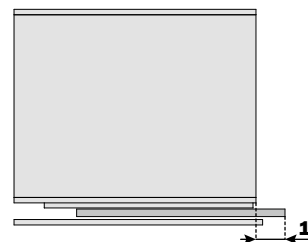
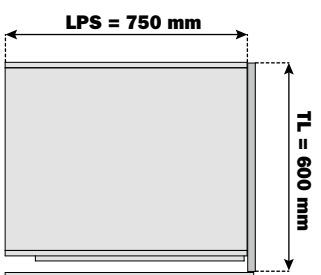

**LPS ≥ TL**



**LPS < TL**

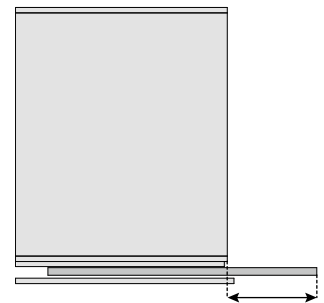
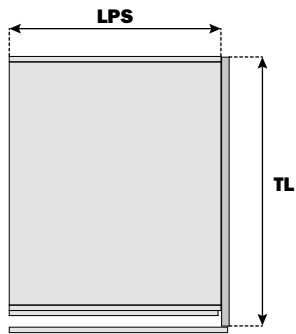
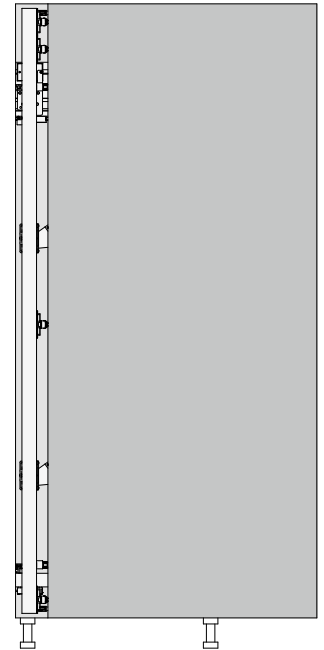
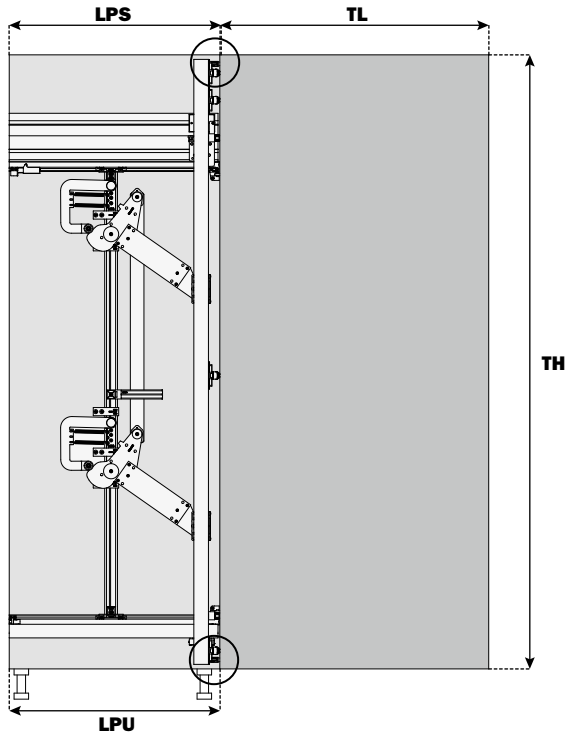
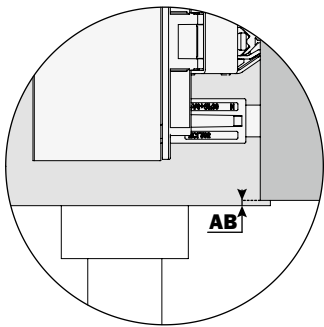
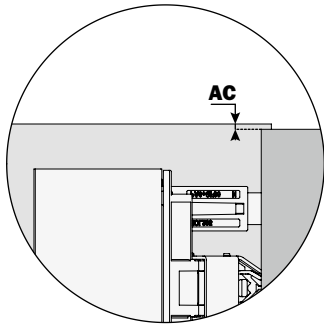

**TL + 107 mm - LPS**

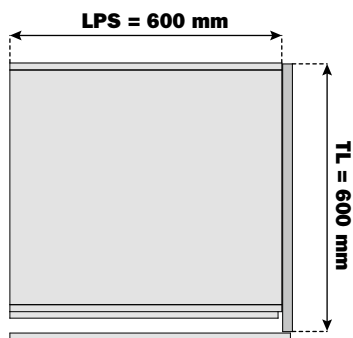

**LPS = TL**

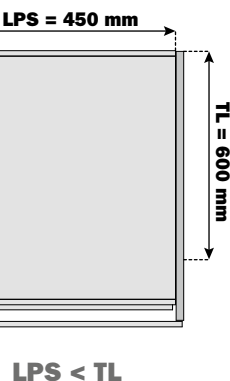
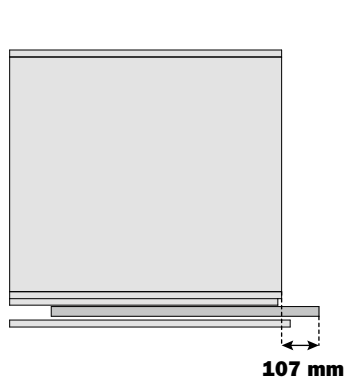

**LPS < TL**

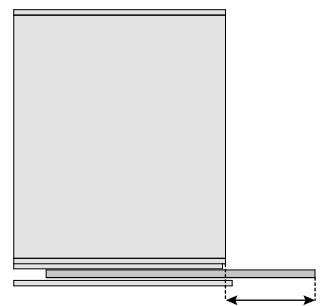

**600 + 107 - 450 = 257 mm**



- 
- Meccanismo parzialmente assemblato
  - Partially assembled mechanism
  - Teilmontierter Mechanismus
  - Mécanisme partiellement assemblé
  - Mecanismo parcialmente ensamblado
  - Mecanismo parcialmente montado
  - 部分预装版本

[ITA] **Contenuto imballi**

**Meccanismo parzialmente assemblato**

- 1930 - 2230 mm: 4 cerniere (max 24 Kg)
- 2231 - 2530 mm: 5 cerniere (max 30 Kg)

[ENG] **Pack contents**

**Partially assembled mechanism**

- 1930 - 2230 mm: 4 hinges (max 24 Kg)
- 2231 - 2530 mm: 5 hinges (max 30 Kg)

[ESP] **Relación contenido embalaje**

**mecanismo parcialmente ensamblado**

- 1930 - 2230 mm: 4 bisagras (max 24 Kg)
- 2231 - 2530 mm: 5 bisagras (max 30 Kg)

[DEU] **Verpackungsinhalt**

**Teilmontierter Mechanismus**

- 1930 - 2230 mm: 4 Scharniere (max 24 Kg)
- 2231 - 2530 mm: 5 Scharniere (max 30 Kg)

[POR] **Conteúdo das embalagens do**

**mecanismo parcialmente montado**

- 1930 - 2230 mm: 4 dobradiça (max 24 Kg)
- 2231 - 2530 mm: 5 dobradiça (max 30 Kg)

[FRA] **Contenu des emballages**

**Mecanisme partiellement assemble**

- 1930 - 2230 mm : 4 charnière ( max 24 Kg )
- 2231 - 2530 mm : 5 charnière ( max 30 Kg )

[ZH] **包装组件**

**部分预装版本**

- 1930 - 2230 mm: 4 hinges (max 24 Kg)
- 2231 - 2530 mm: 5 hinges (max 30 Kg)

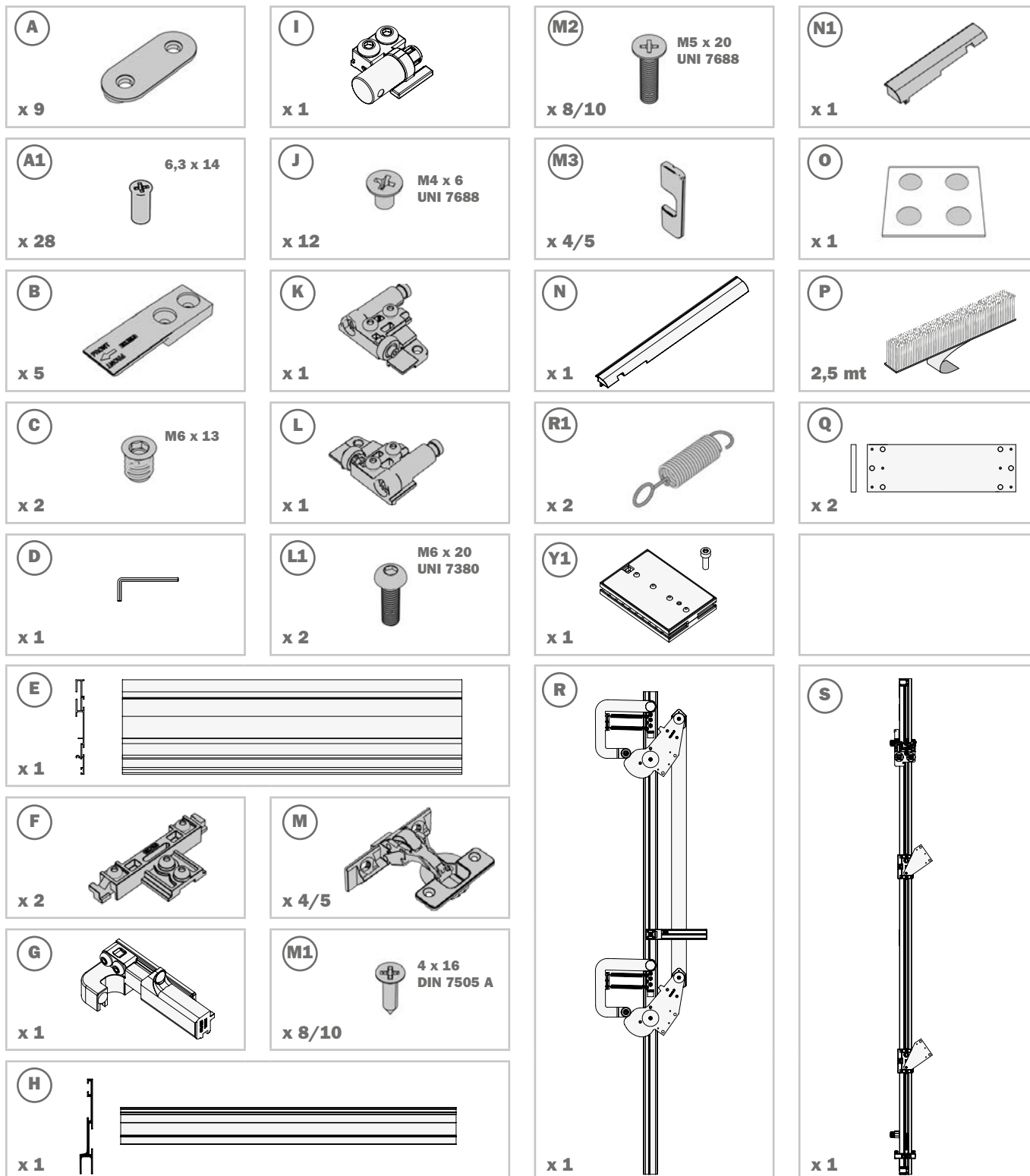

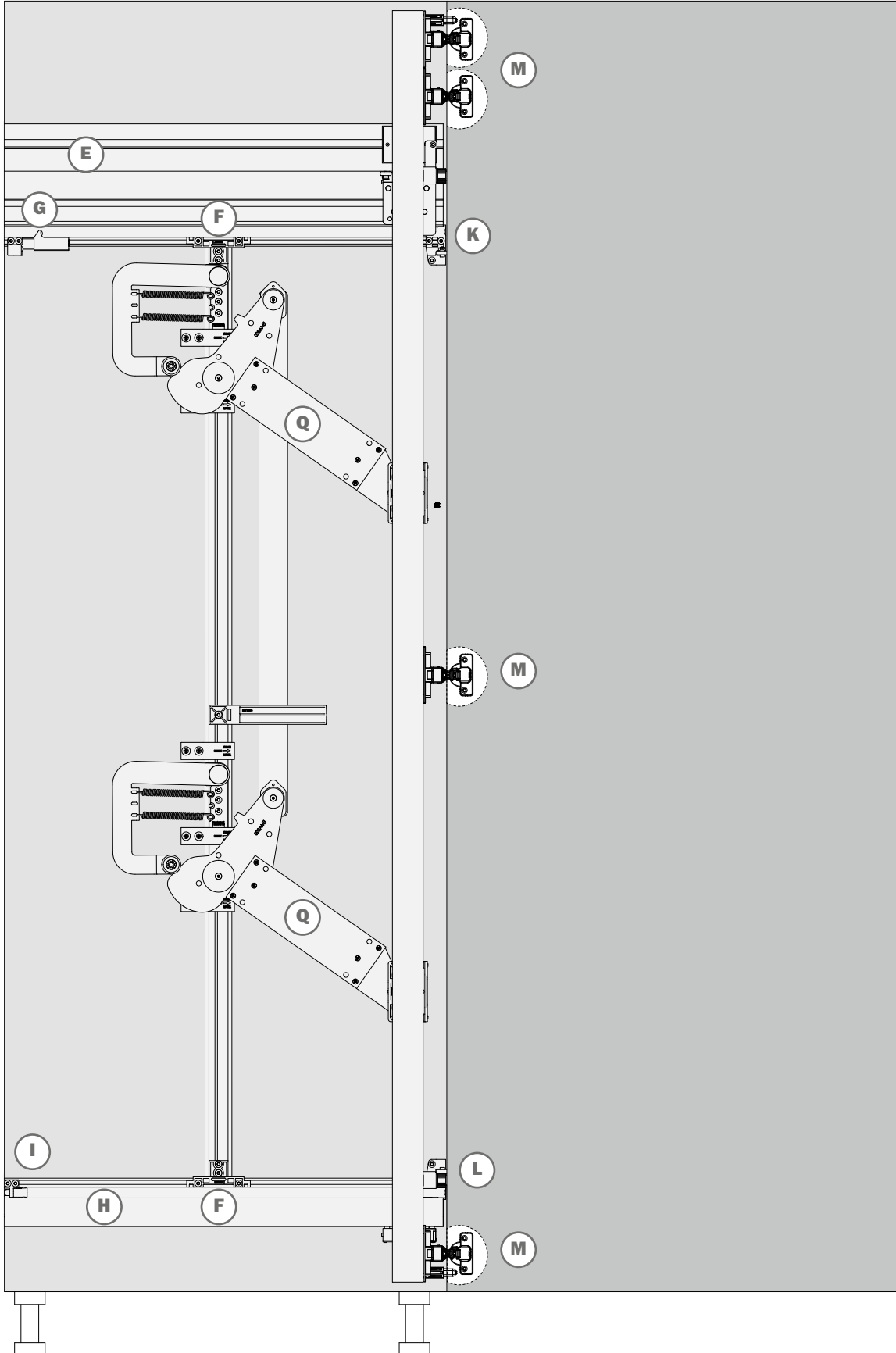

[ITA] montaggio del meccanismo

[ENG] Assembly of the mechanism

[ESP] Montaje del mecanismo

[DEU] Montage Des Mechanismus

[POR] Montagem do mecanismo

[FRA] Montage du mecanisme

[ZH] 组装系统机构

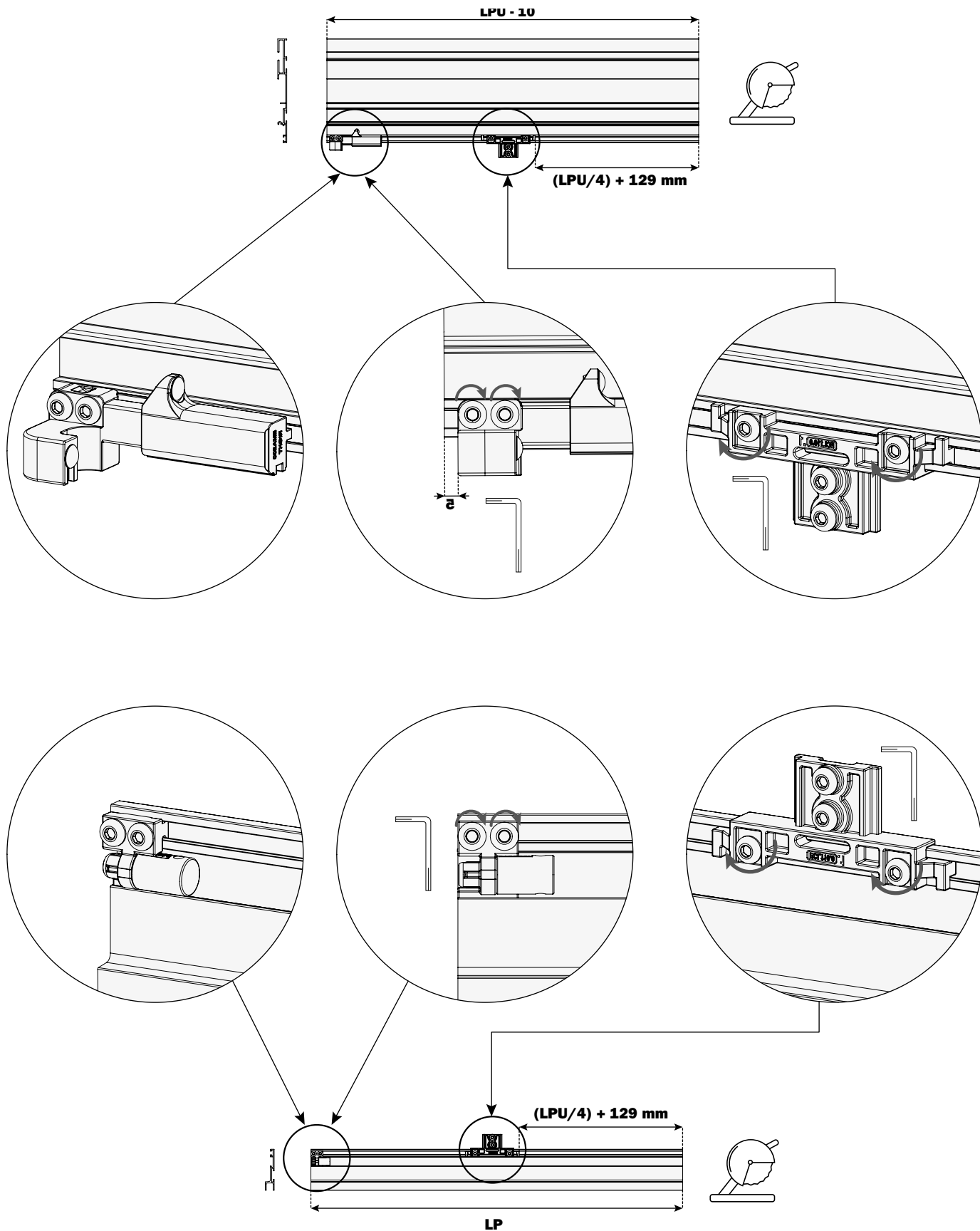

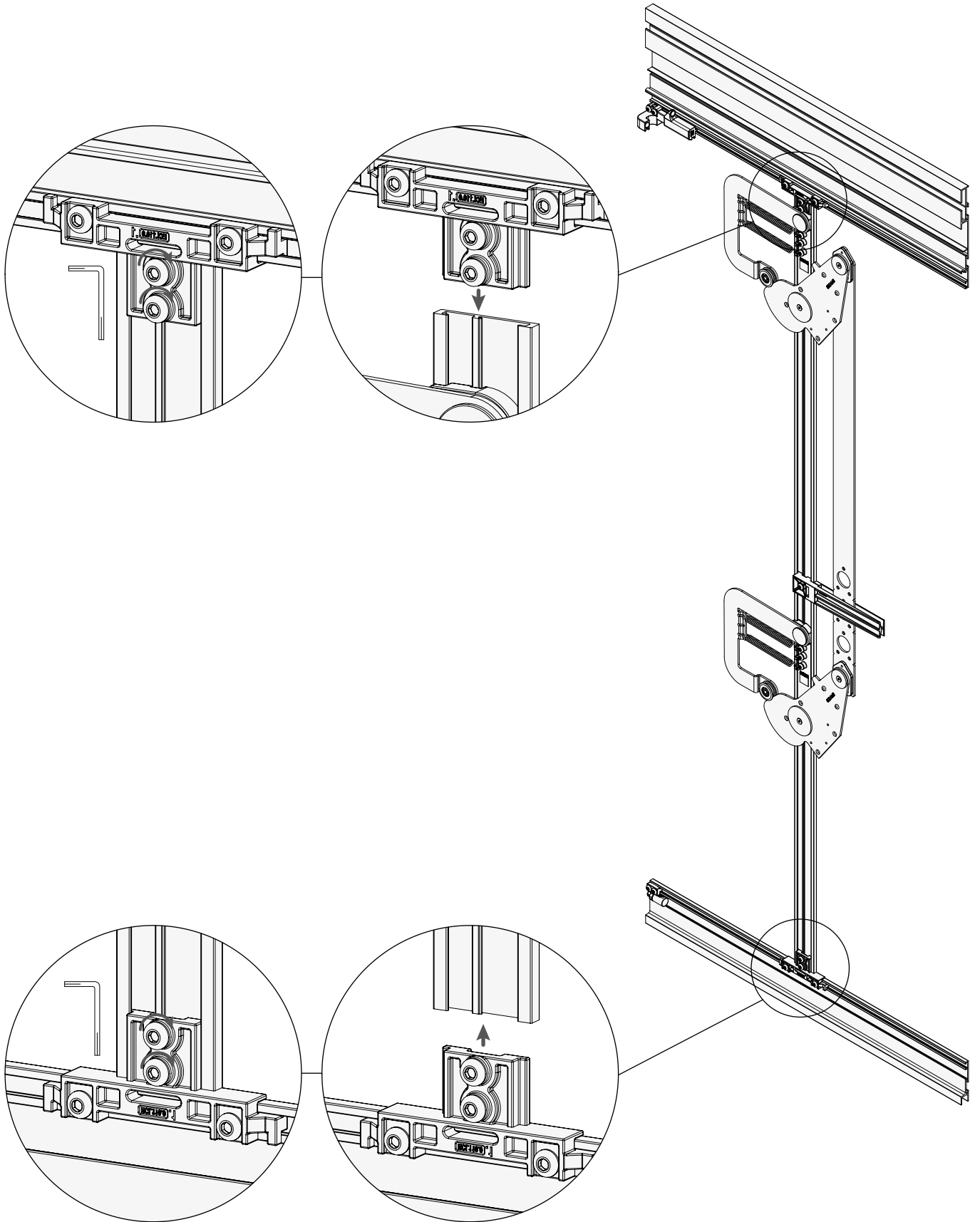

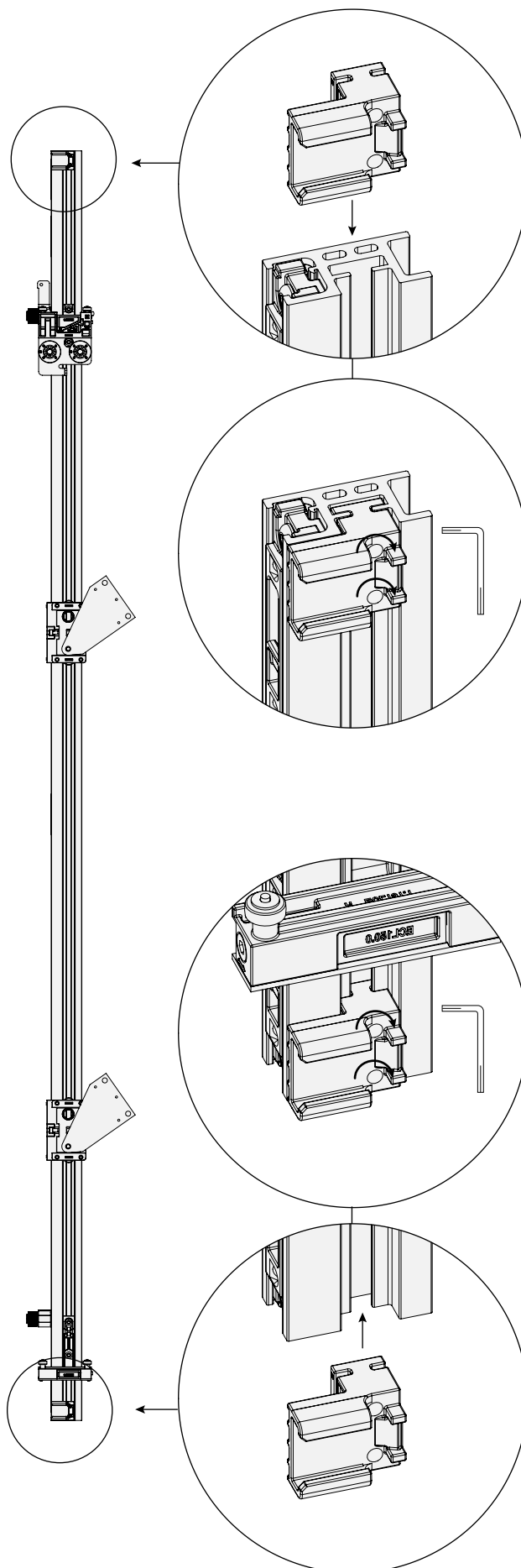

**OPTIONAL  
KIT SMOVE  
VE55KIT0050  
VE55KIT0055**

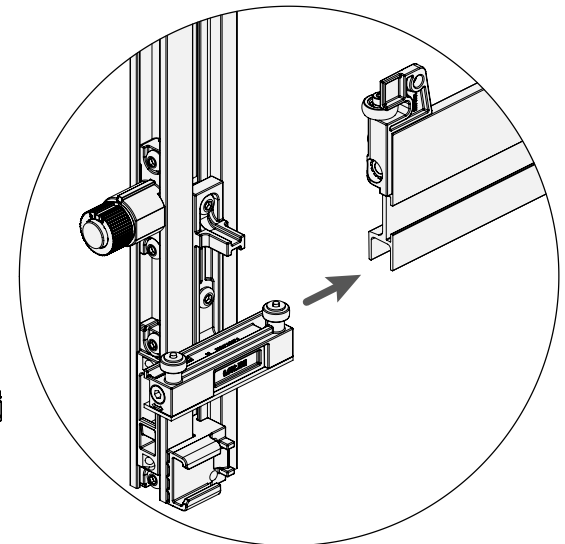
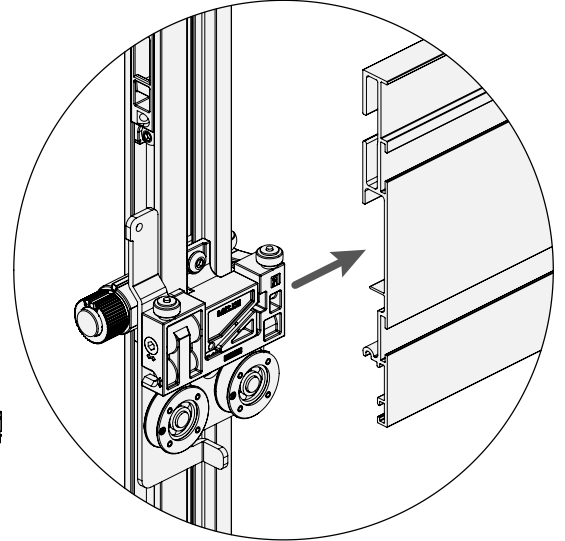
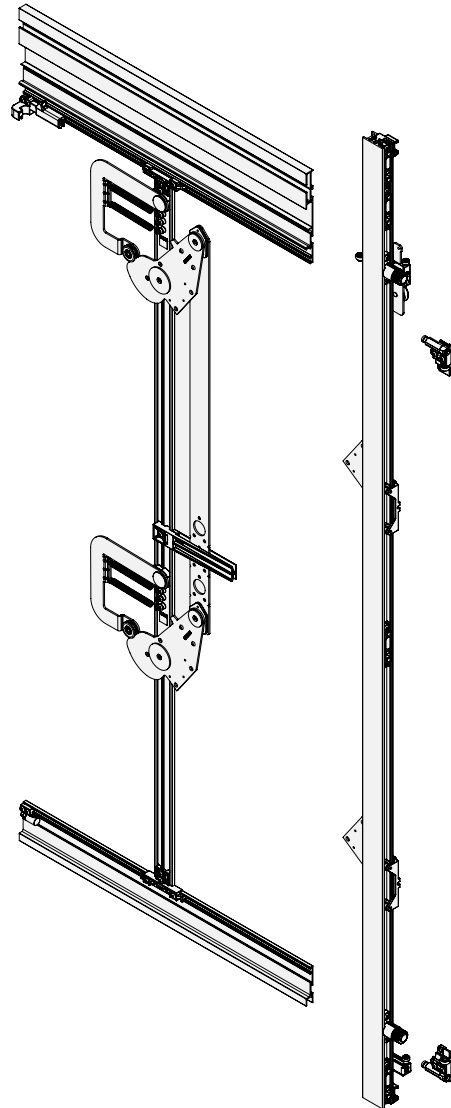
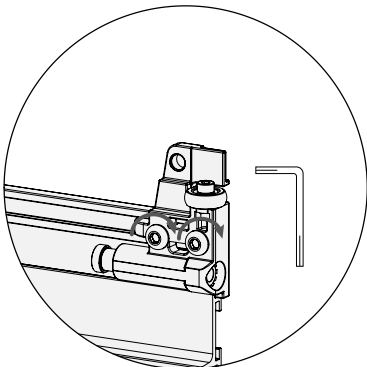
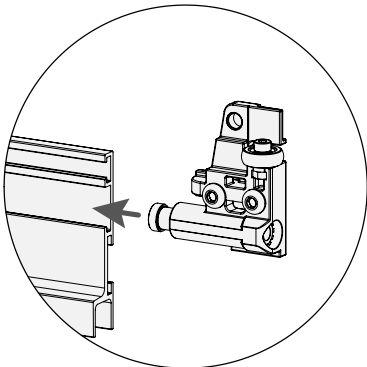
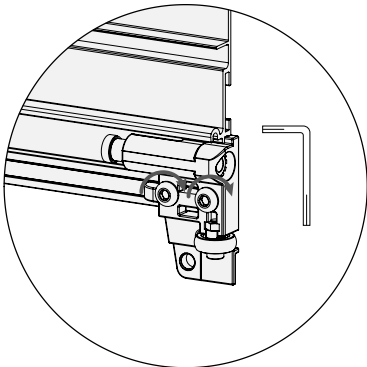
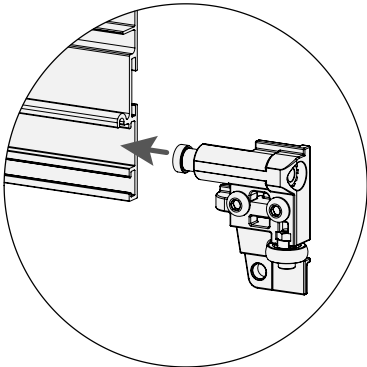

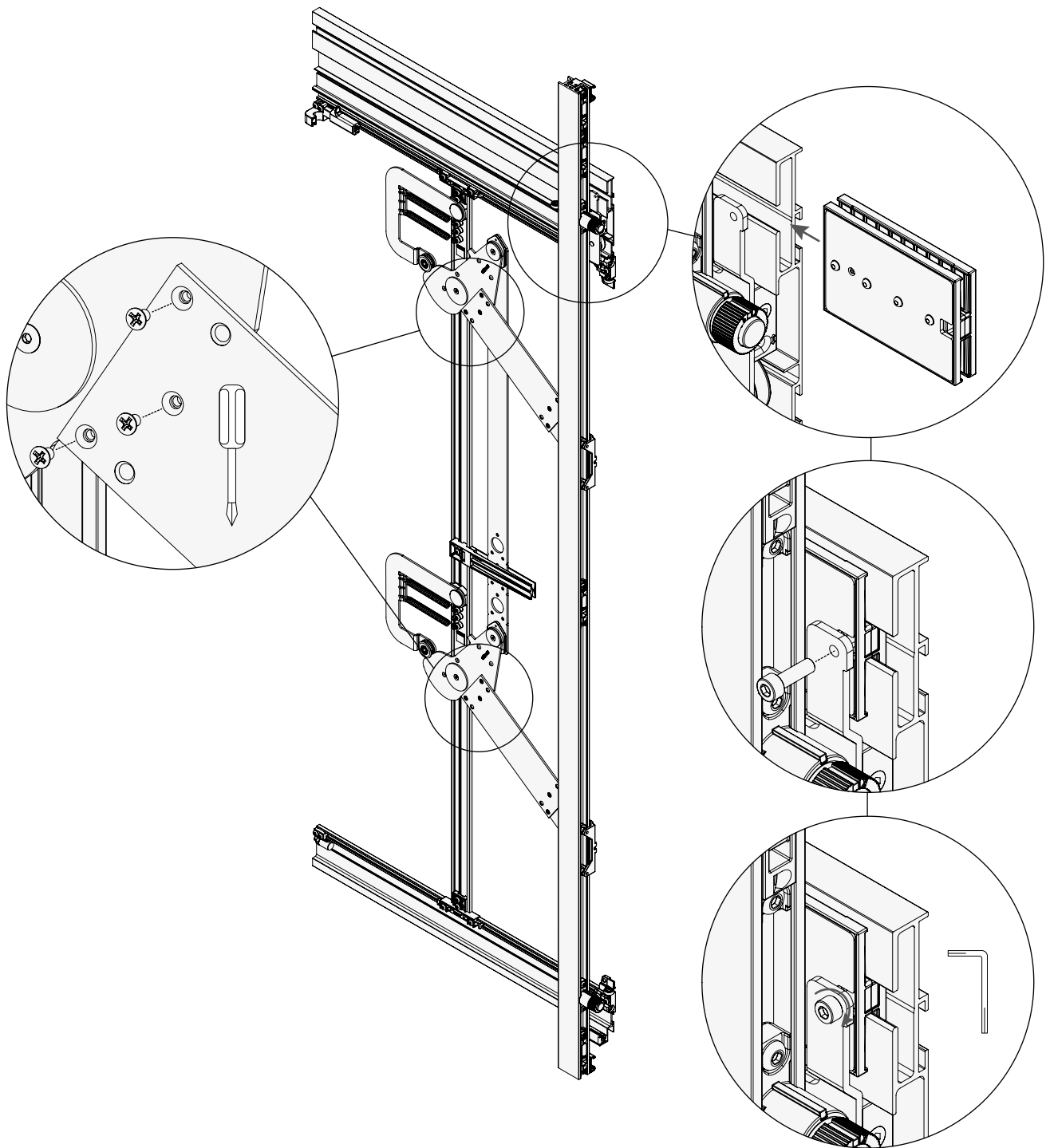





[ITA] Lavorazioni sull'anta

[ENG] Door drillings

[ESP] Mecanizados en la puerta

[DEU] Bearbeitungen der Tür

[POR] Usinagens na porta

[FRA] Opérations sur la porte

[ZH] 门板孔位

TH 1930 • 2230 mm - anta standard  
standard door  
Standardtür  
porte standard  
puerta estándar  
porta convencional  
标准门

 TH 1956 - 2256 mm - anta con telaio  
door with frame  
Tür mit Rahmen  
porte avec cadre  
puerta con marco  
porta com moldura  
带框架门

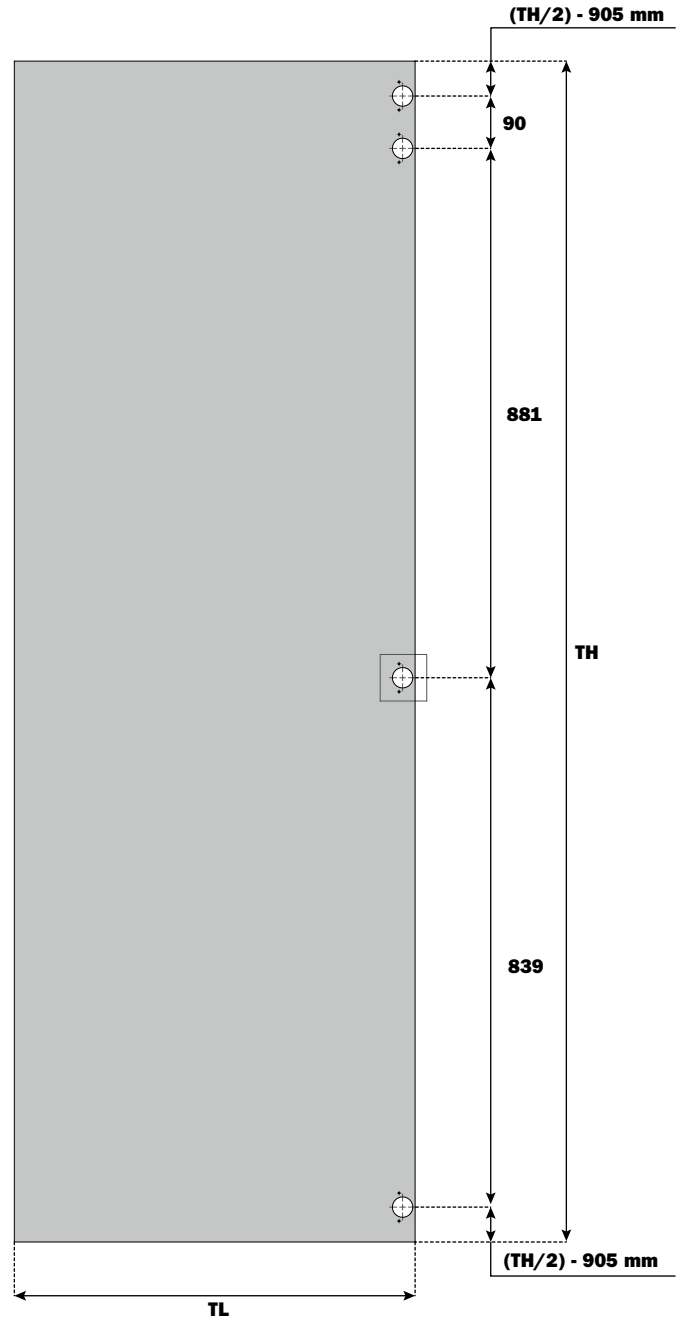
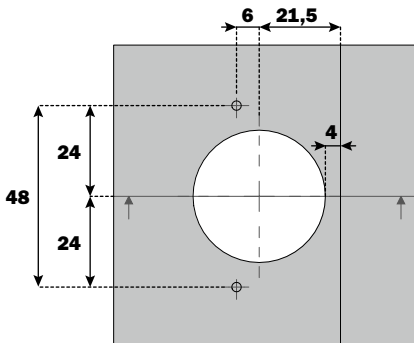
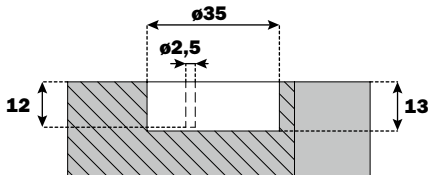
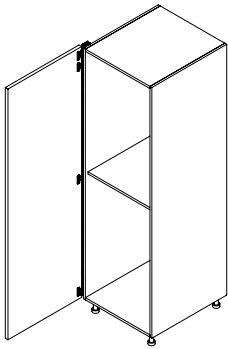



[ITA] Lavorazioni sul fianco

[ENG] Side panel drillings

[ESP] Mecanizados en el lateral

[DEU] Bearbeitungen der Seite

[POR] Usinagens na lateral

[FRA] Opérations sur le côté

[ZH] 侧板孔位

TH 1930 • 2230 mm - anta standard  
standard door  
Standardtür  
porte standard  
puerta estándar  
porta convencional  
标准门

  
TH 1956 - 2256 mm - anta con telaio  
door with frame  
Tür mit Rahmen  
porte avec cadre  
puerta con marco  
porta com moldura  
带框架门

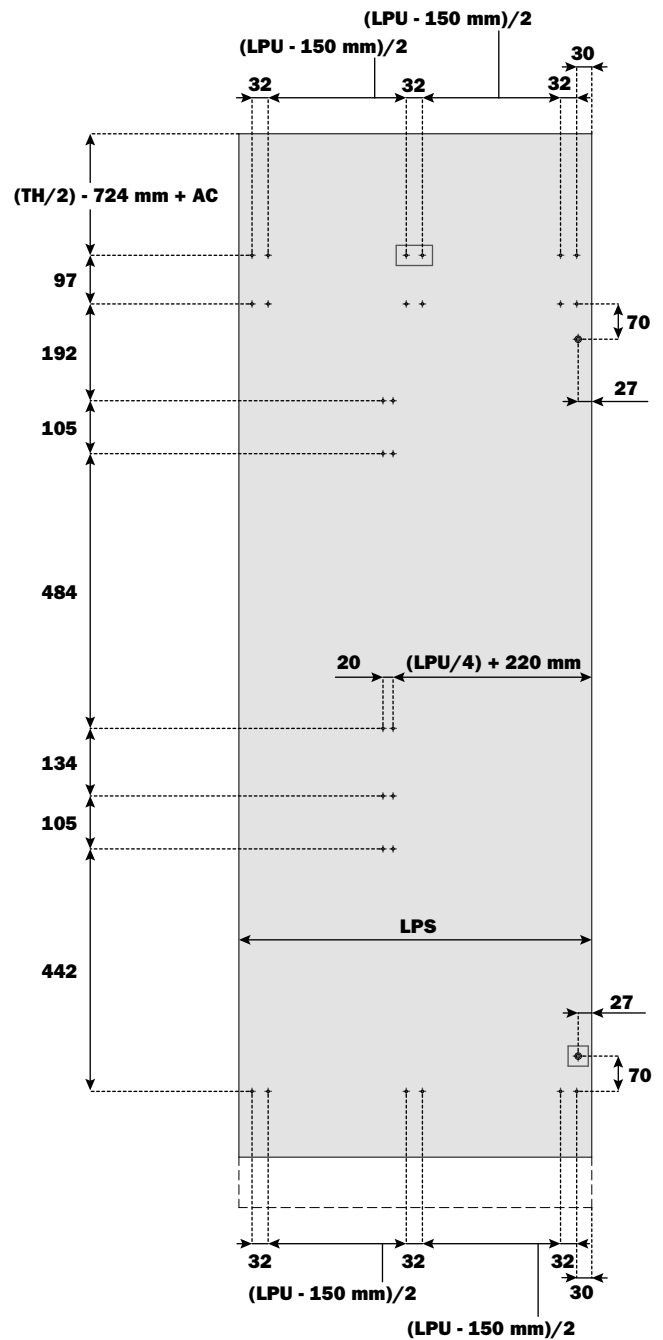
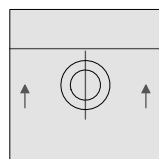
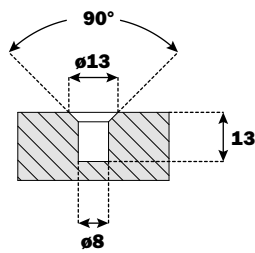
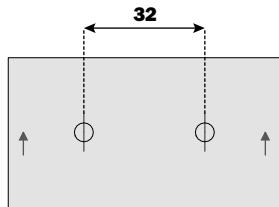
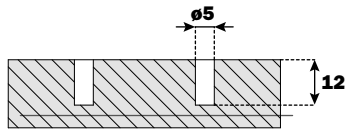
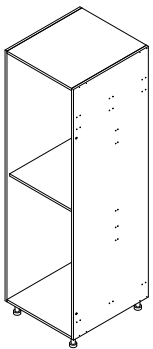

- 
- Montaggio del meccanismo sul mobile
  - Fitting the mechanism to the cabinet
  - Montage des Mechanismus am Möbel
  - Montage du mécanisme sur le meuble
  - Montaje del mecanismo en el mueble
  - Montagem do mecanismo no móvel
  - 系统机构安装至柜体



[ITA] Applicazione delle clip

[ENG] Fixing the clips

[ESP] Aplicación de los clips

[DEU] Befestigung der clips

[POR] Aplicação dos cliques

[FRA] Installation des clips

[ZH] 固定卡扣

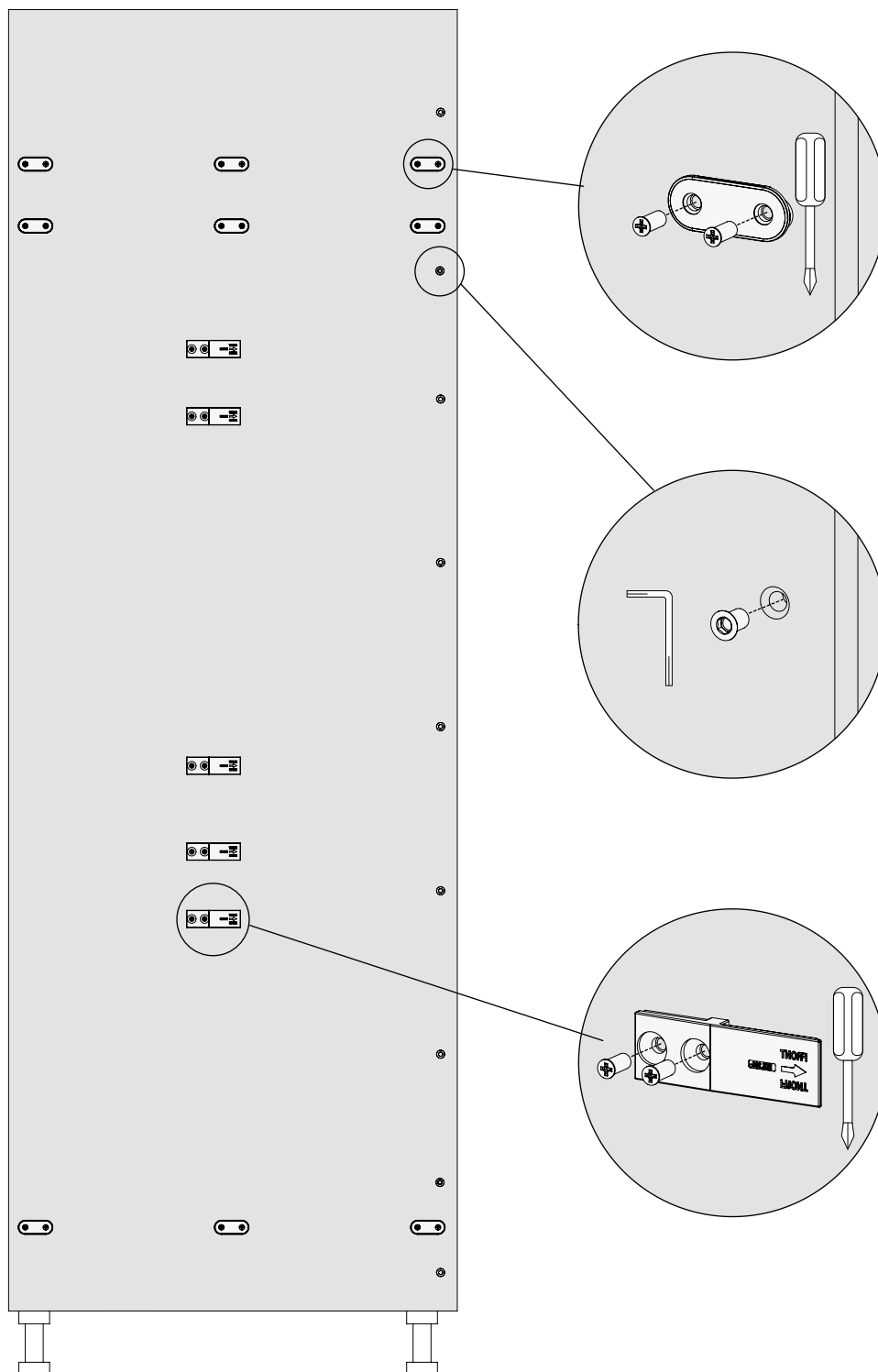
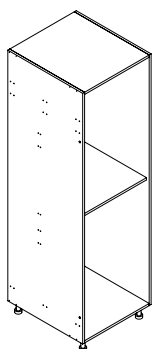

[ITA] Montaggio del meccanismo sul mobile

[ENG] Fitting the mechanism to the cabinet

[ESP] Montaje del mecanismo en el mueble

[DEU] Montage des Mechanismus am Möbel

[POR] Montagem do mecanismo no móvel

[FRA] Montage du mécanisme sur le meuble

[ZH] 系统机构安装至柜体

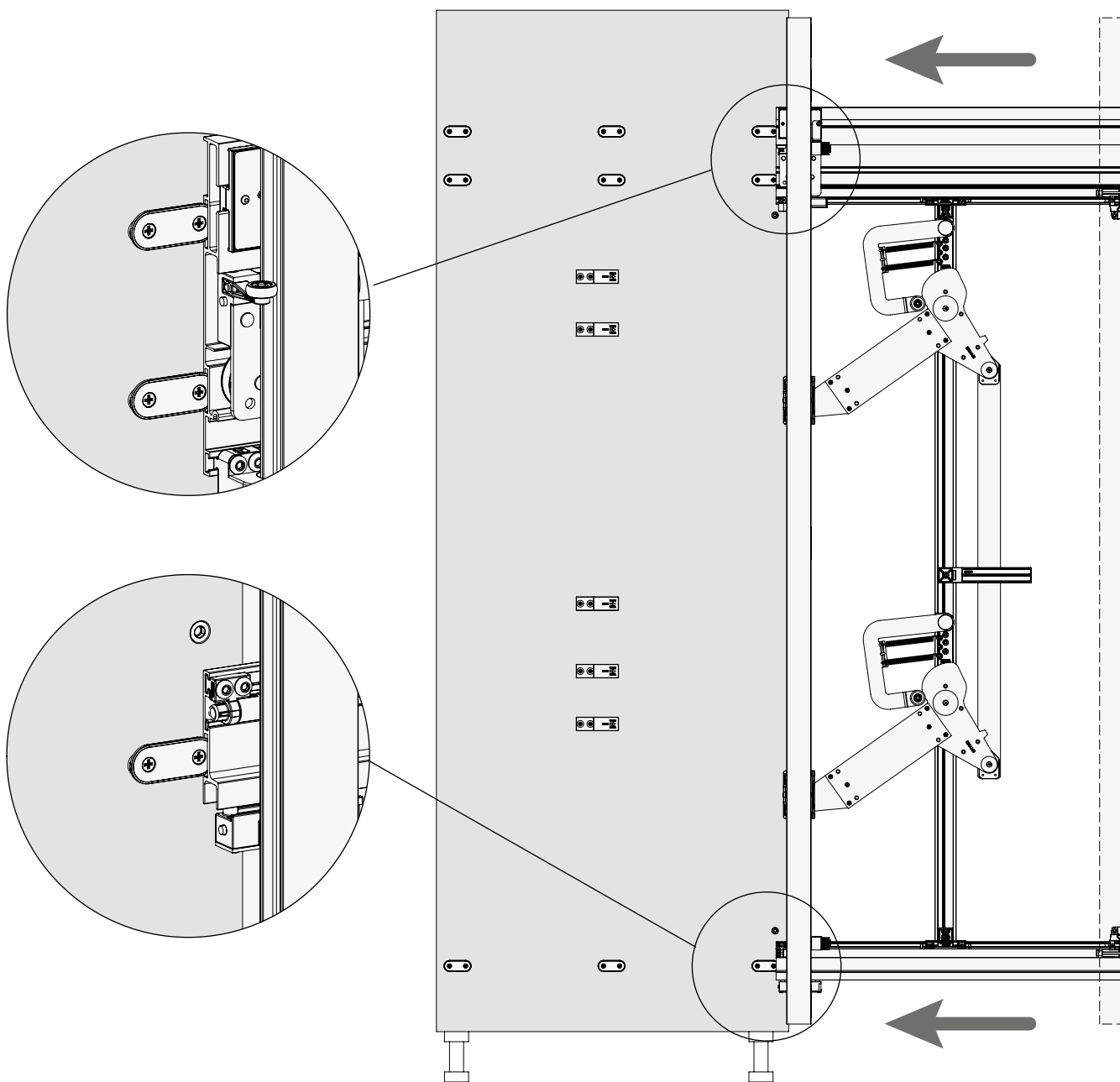

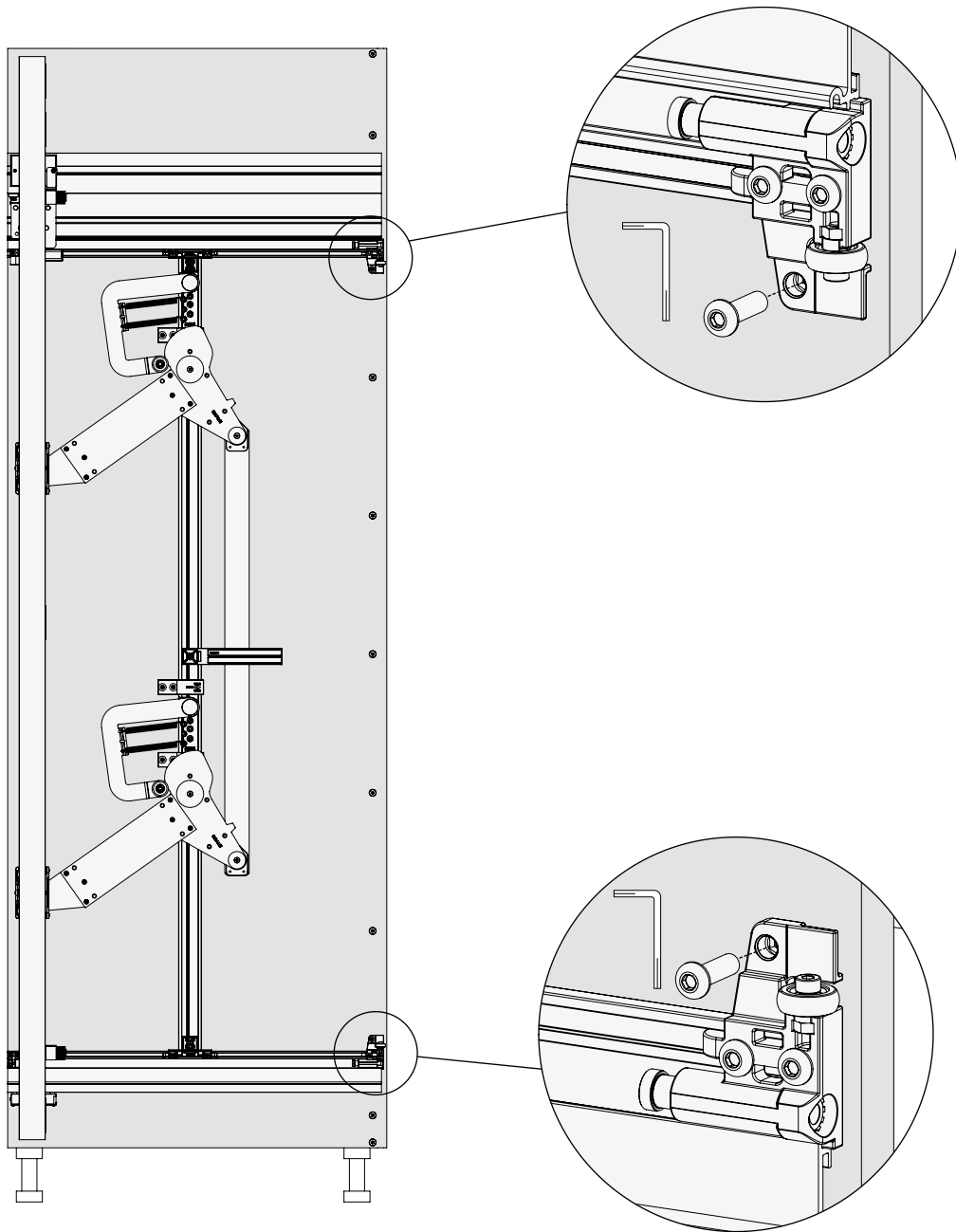



[ITA] Preparazione e montaggio dell'anta

[ENG] Fitting the door onto the mechanism

[ESP] Preparación y montaje de la puerta

[DEU] Vorbereitung und Montage der Tür

[POR] Preparação e montagem da porta

[FRA] Opérations sur la porte et montage

[ZH] 门板安装至系统机构

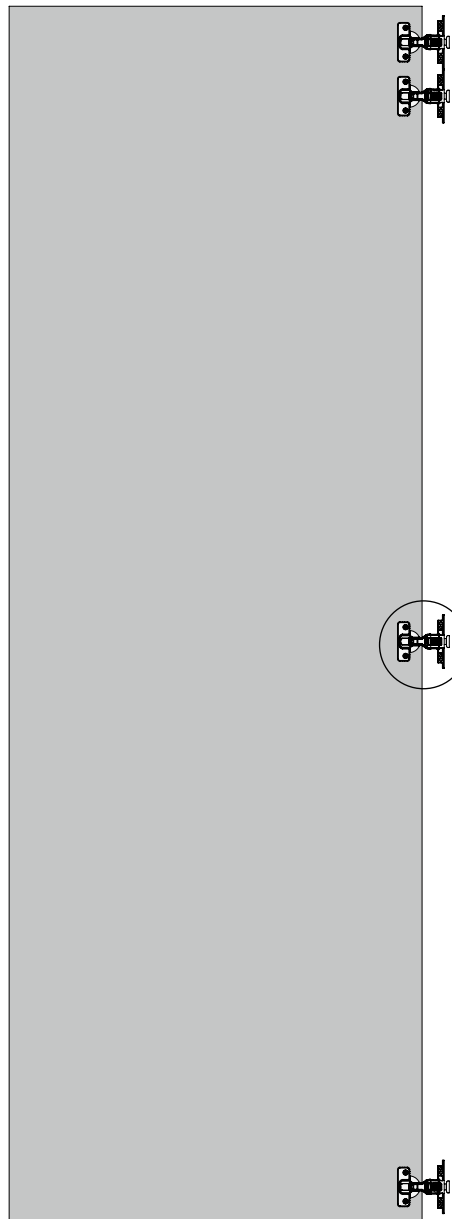
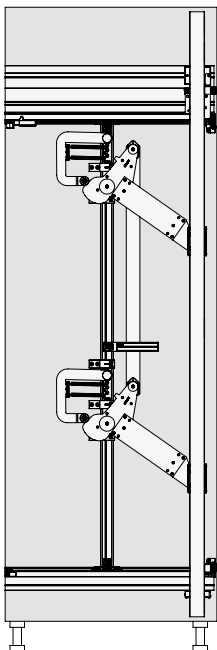
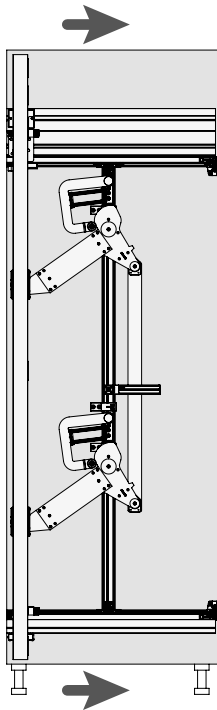

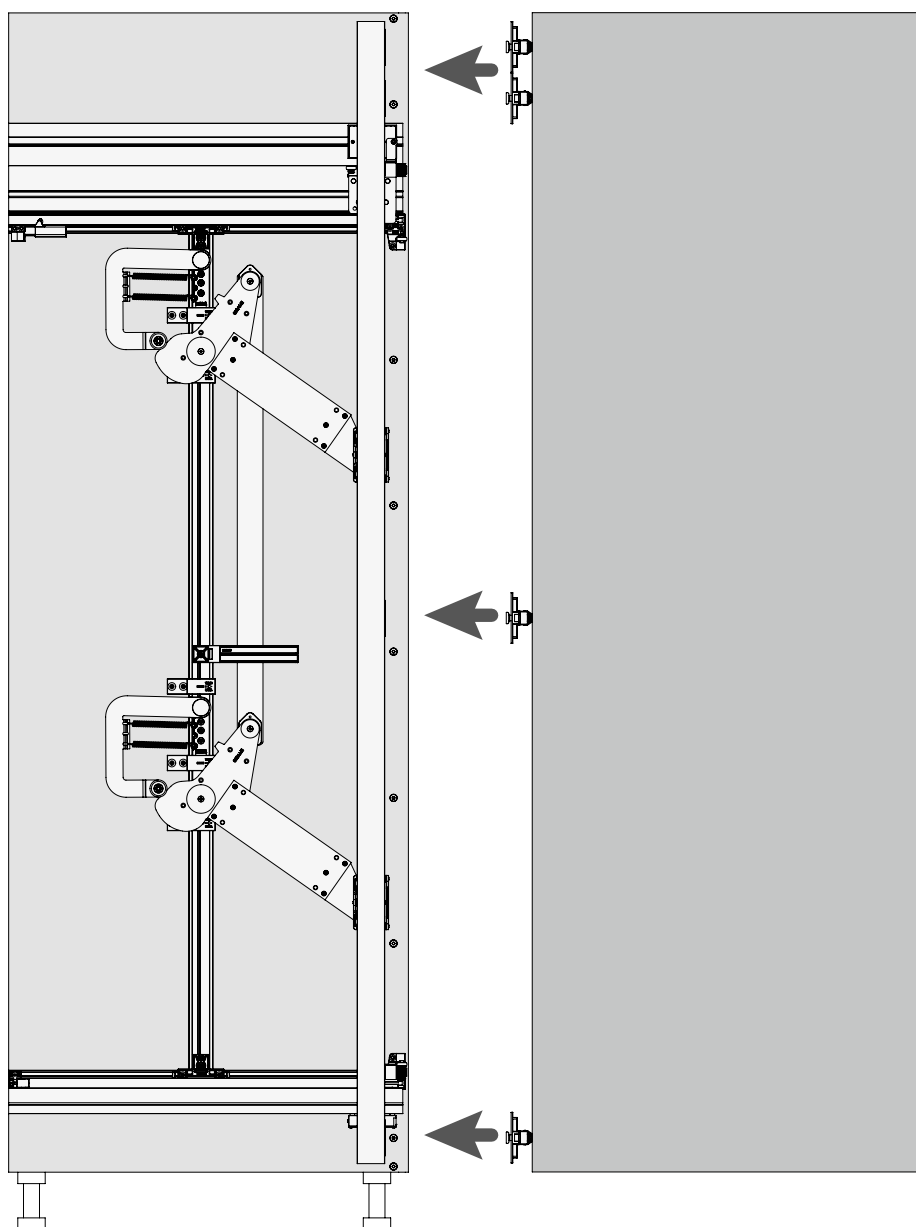
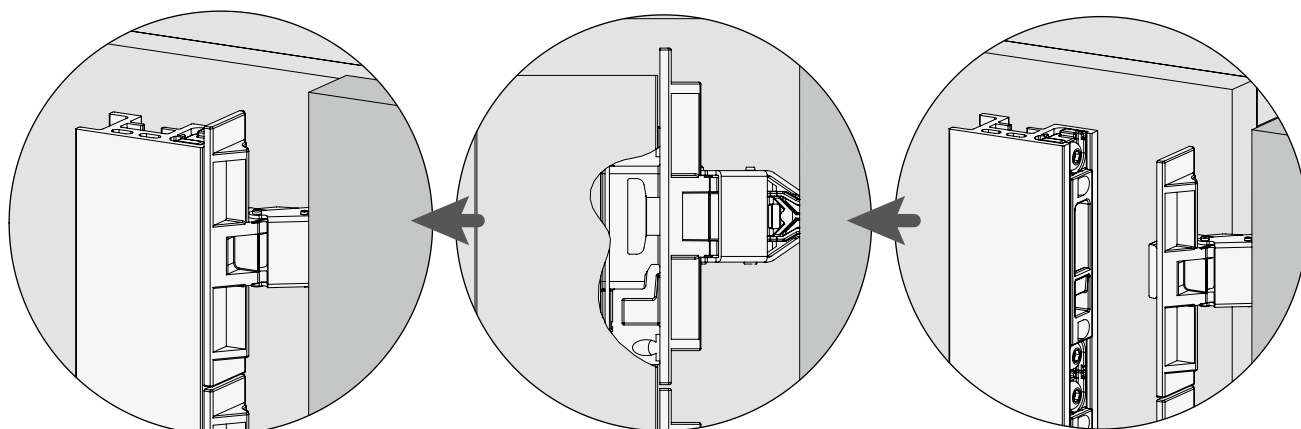



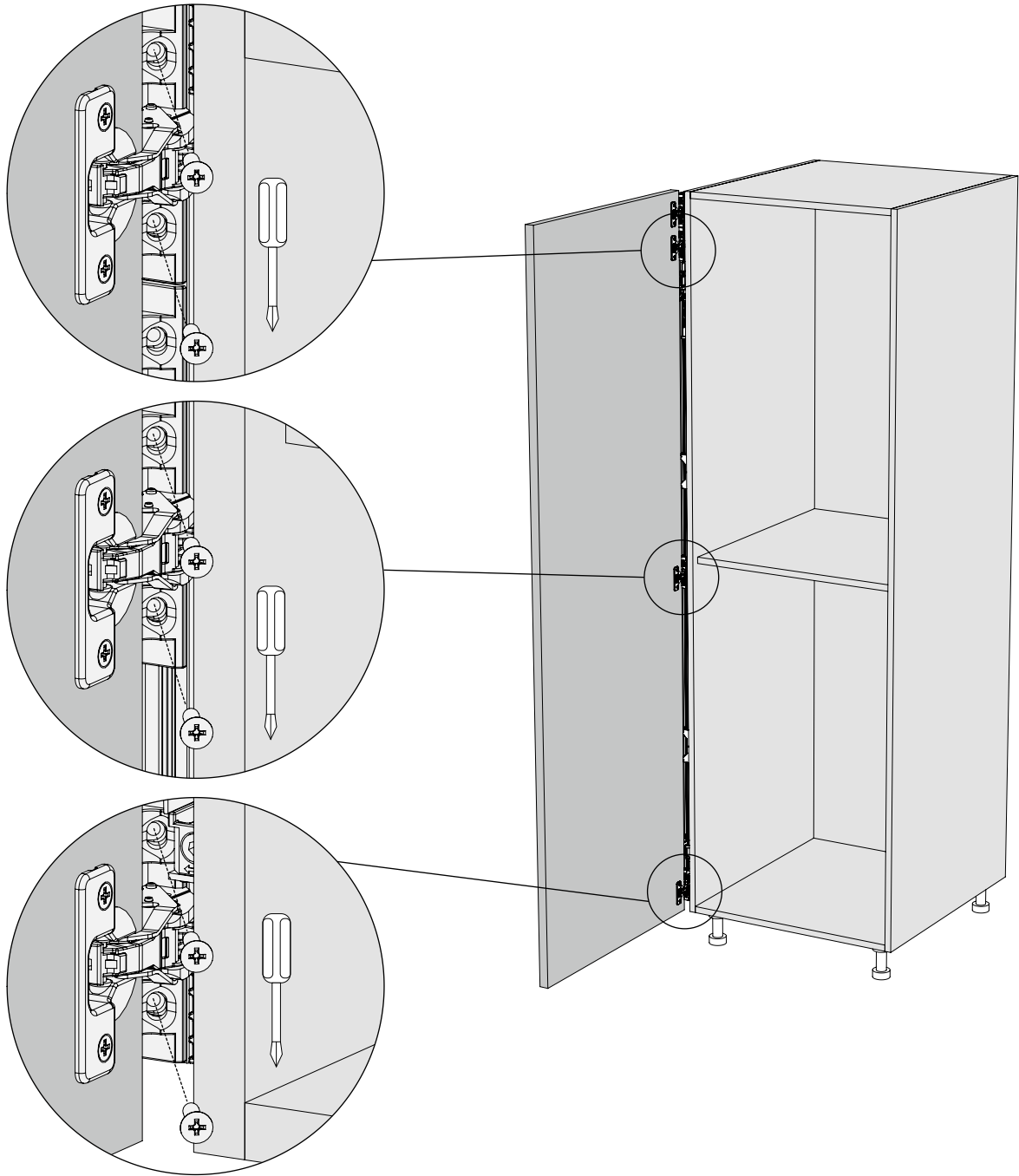

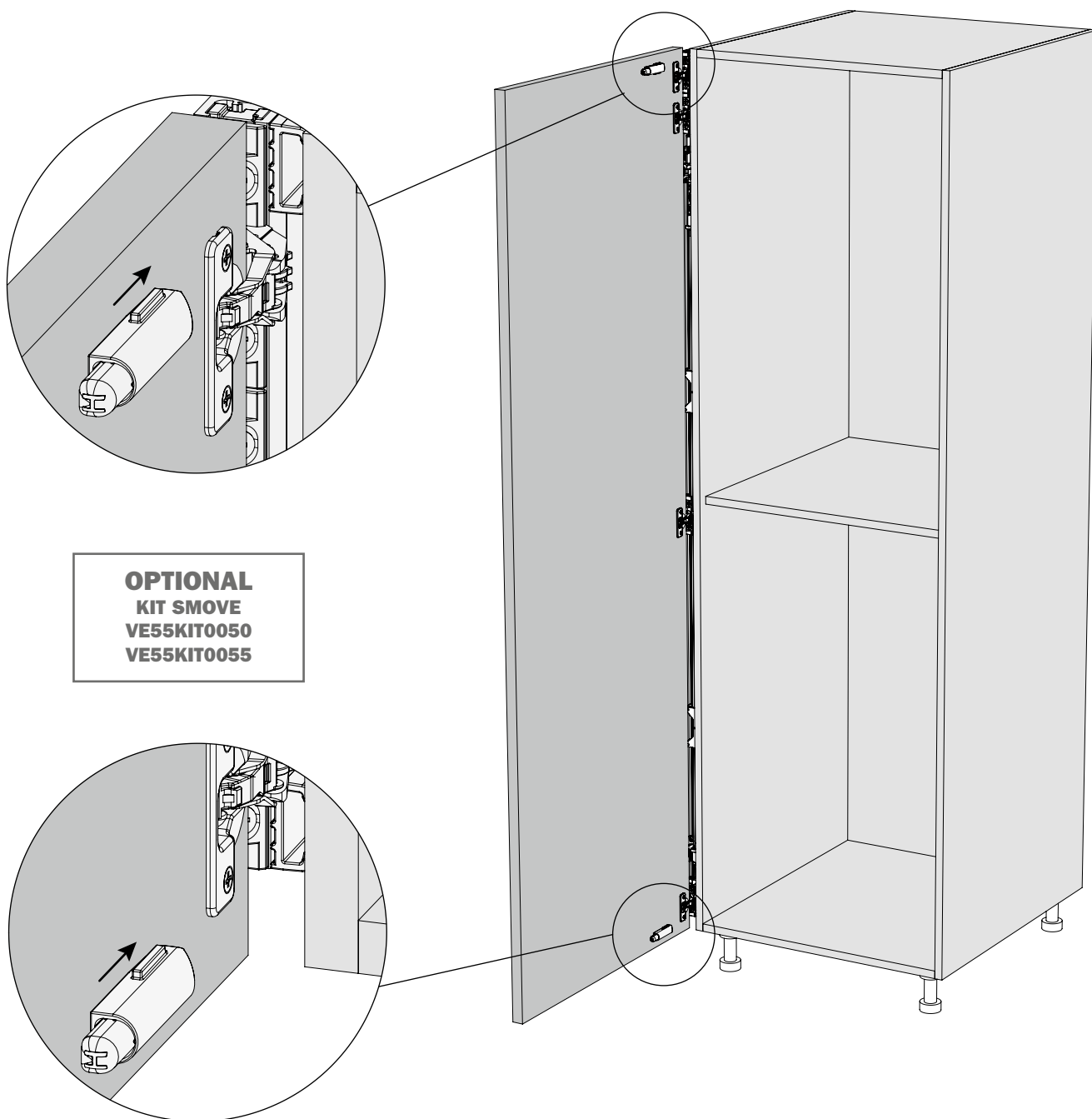

- Regolazioni
- Adjustment
- Verstellung
- Réglage
- Regulaciones
- Regulagens
- 系统机构安装至柜体

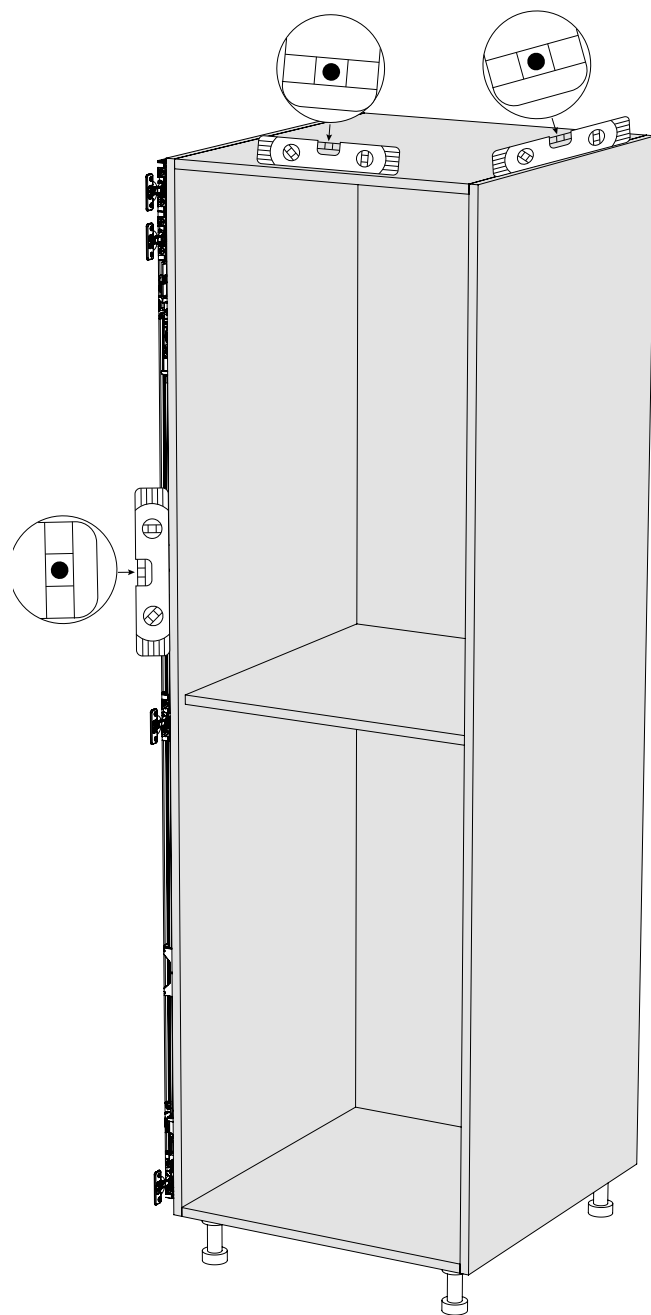



[ITA] **Regolazioni dell'anta**

[ENG] **Adjustment of the door**

[ESP] **Regulaciones de la puerta**

[DEU] **Verstellung der Tür**

[POR] **Regulagens da porta**

[FRA] **Réglage de la porte**

[ZH] **门板调节**

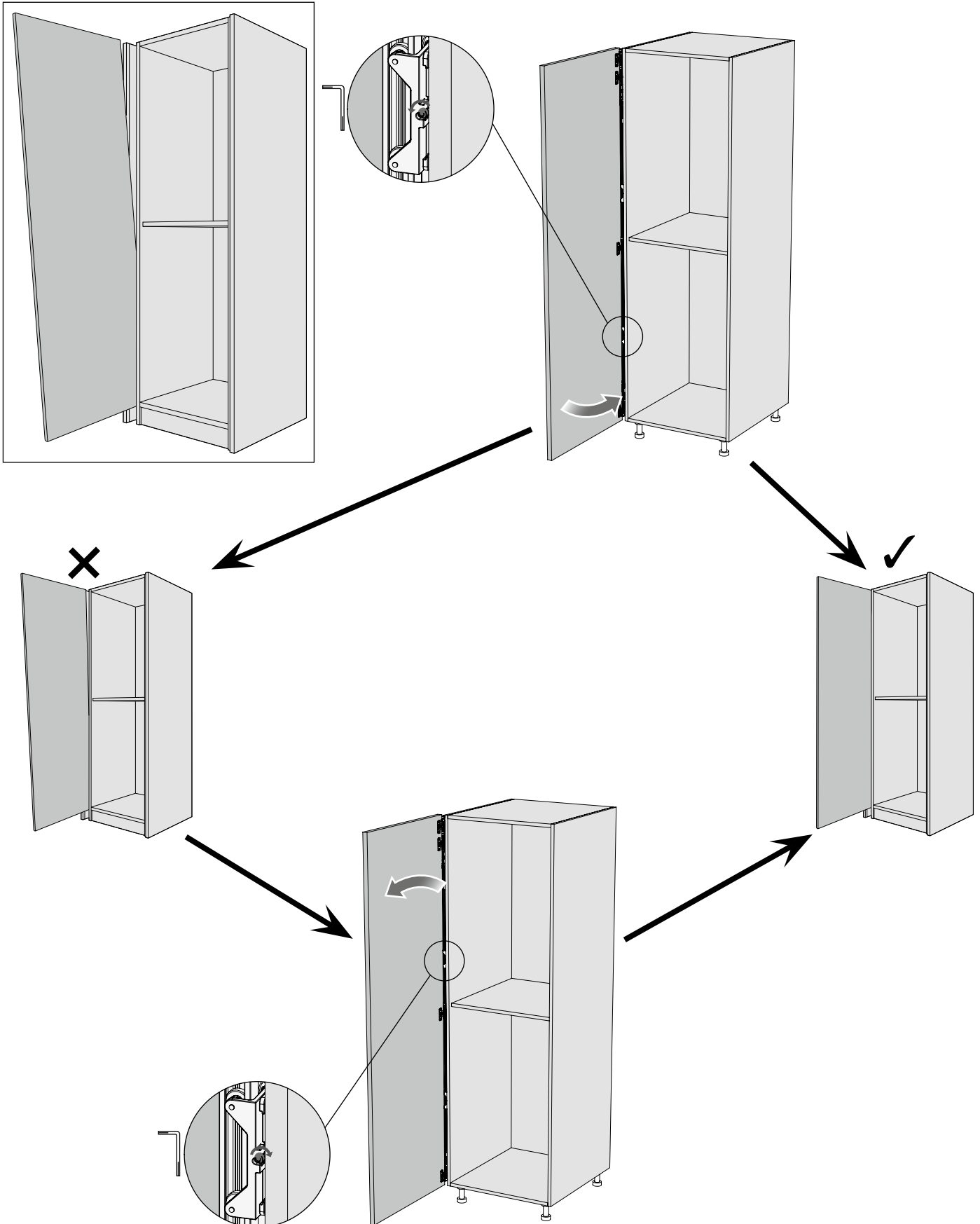

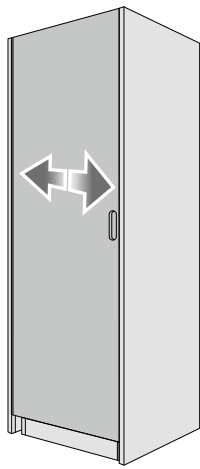

$\pm 2 \text{ mm}$

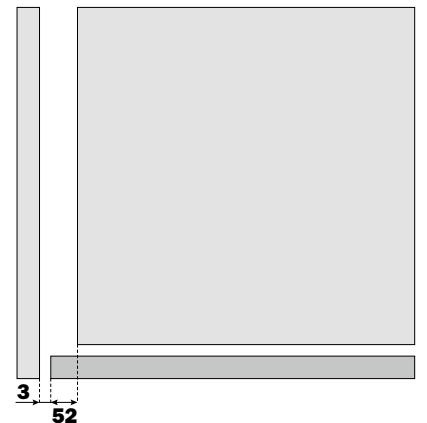
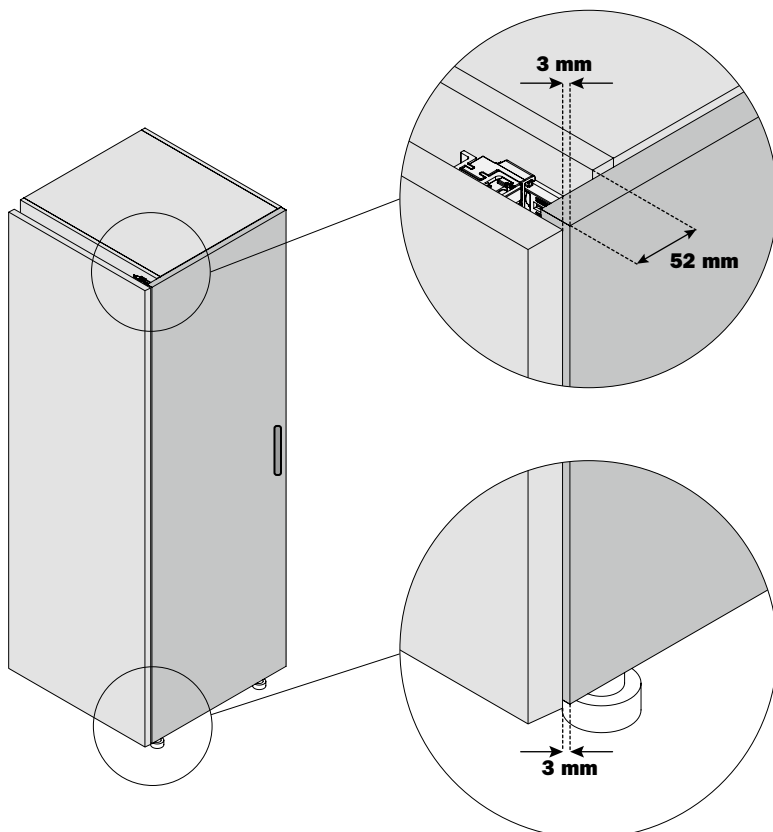
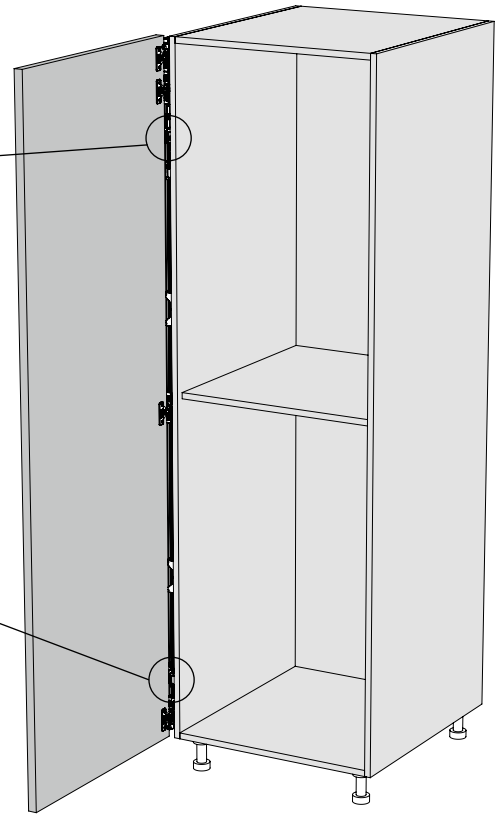
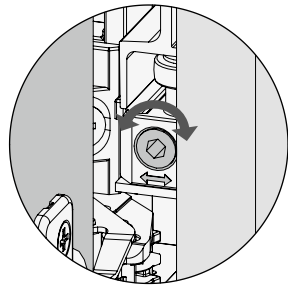
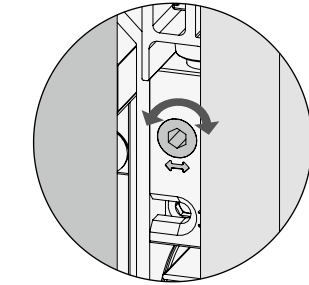

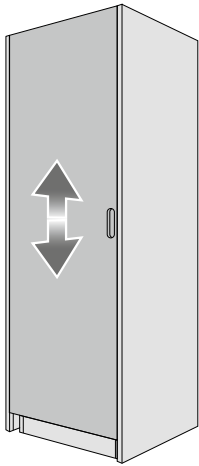

**+4 mm**  
**-1 mm**

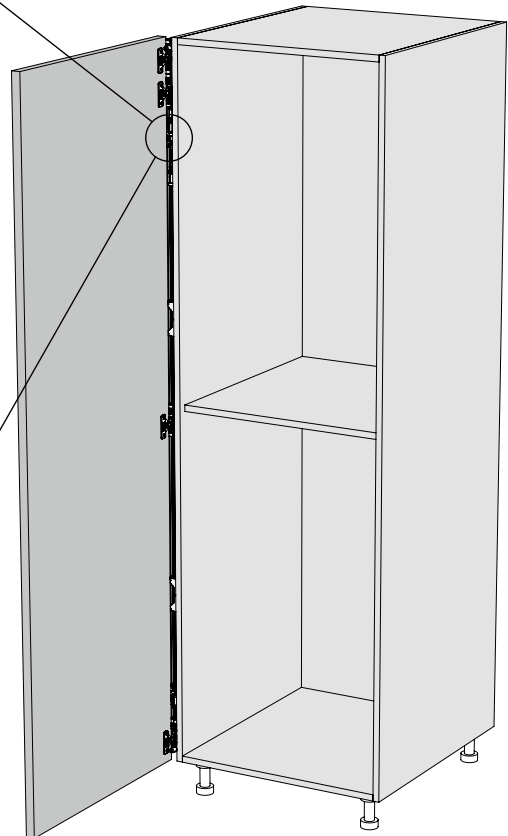
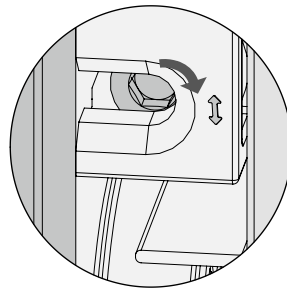
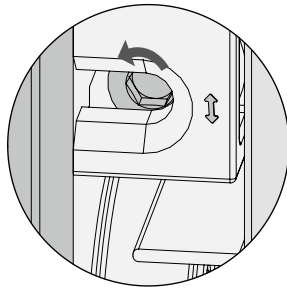

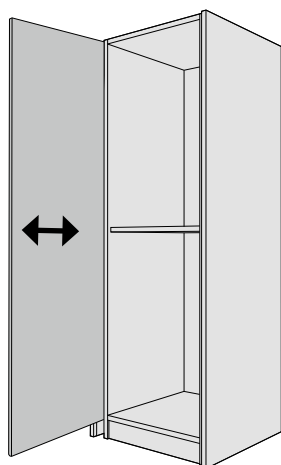

+ 8 mm  
0 mm

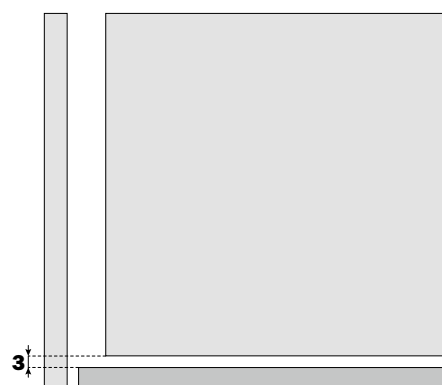
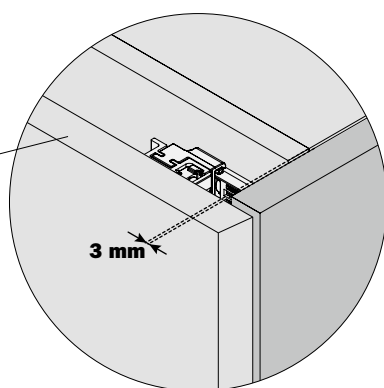
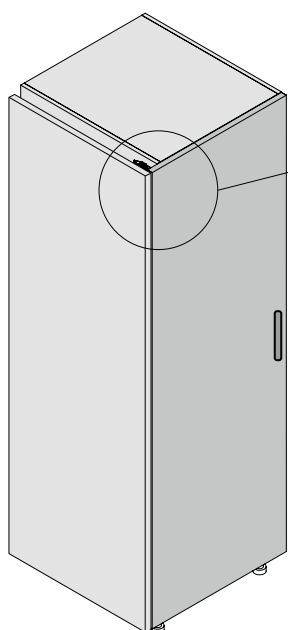
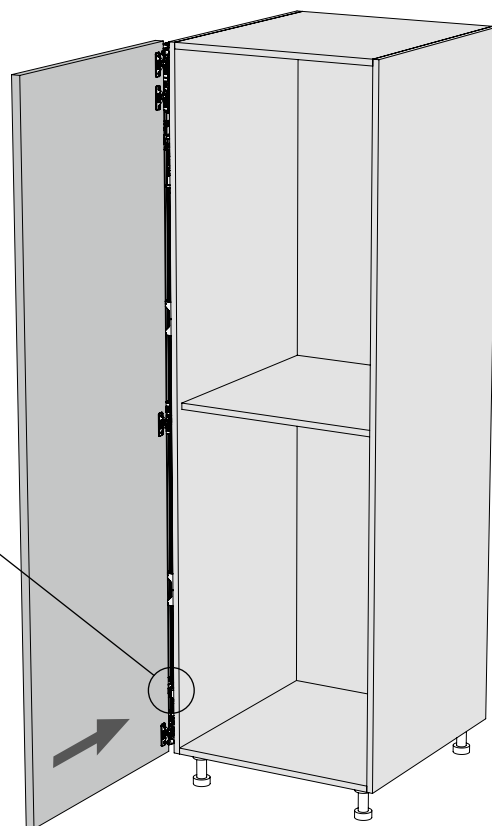
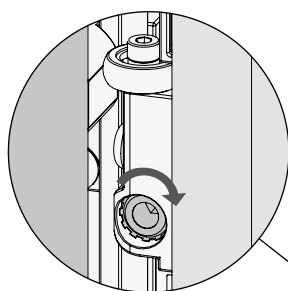



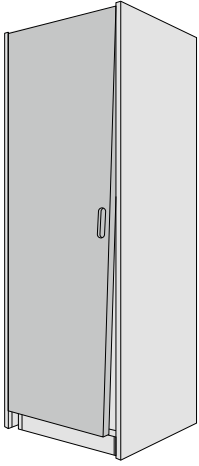

✘

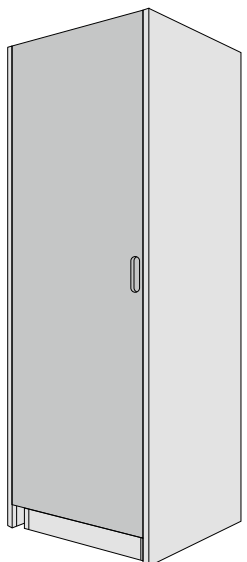
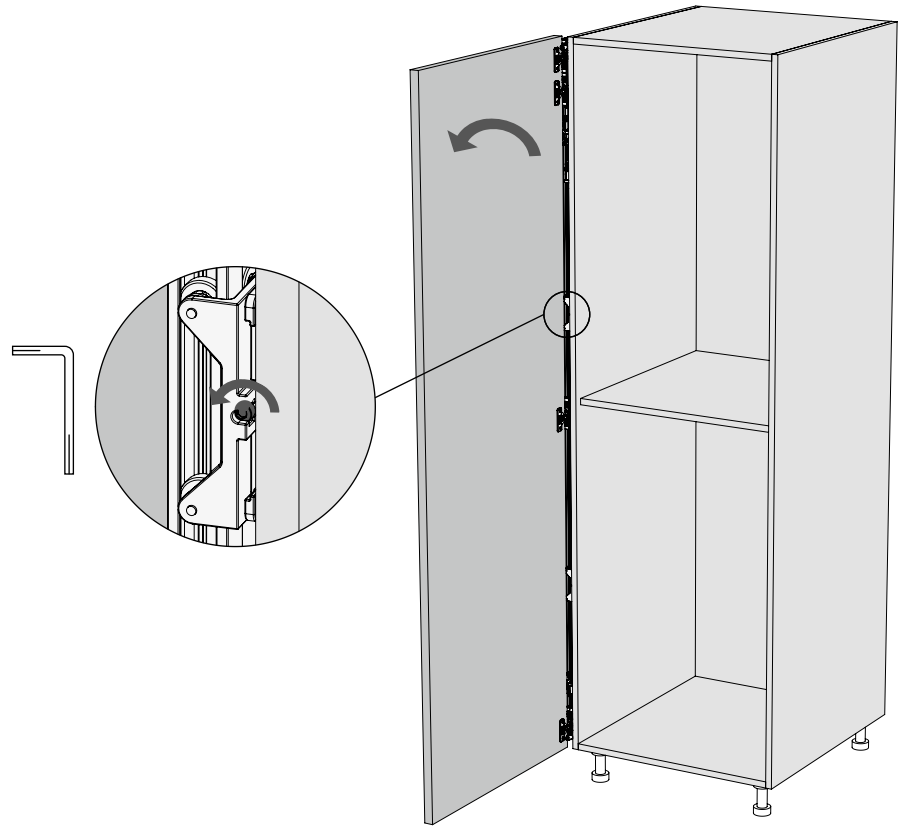

✔

# Exedra

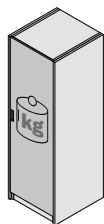
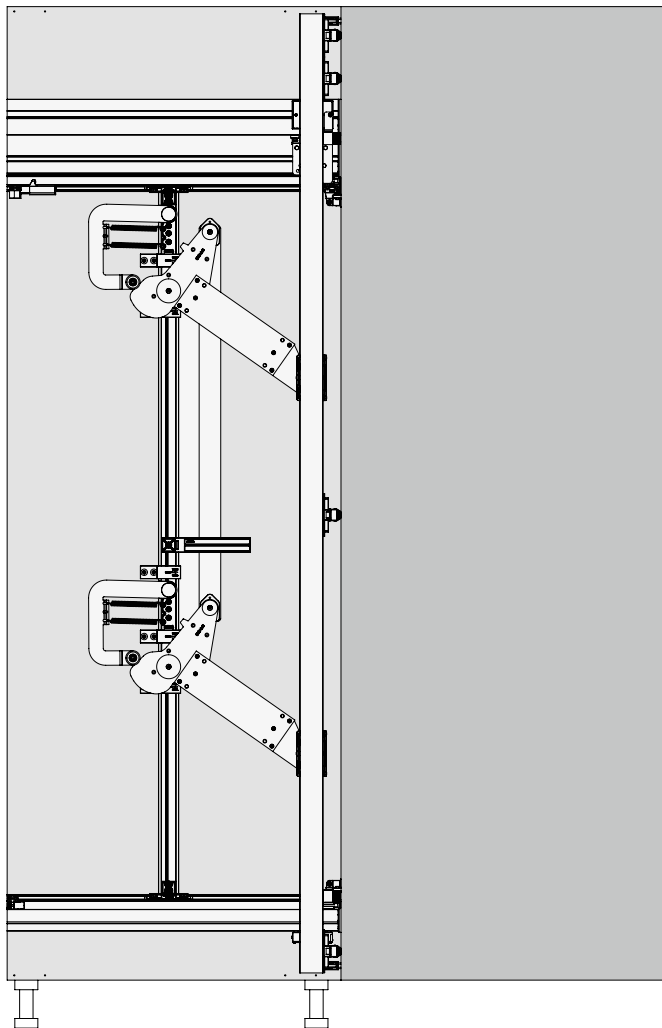
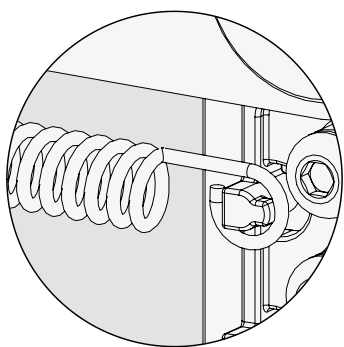
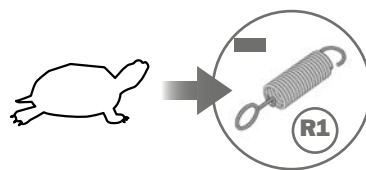
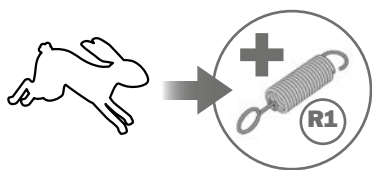

8-15 kg	15-21 kg	21-25 kg	25-28 kg	28-30 kg

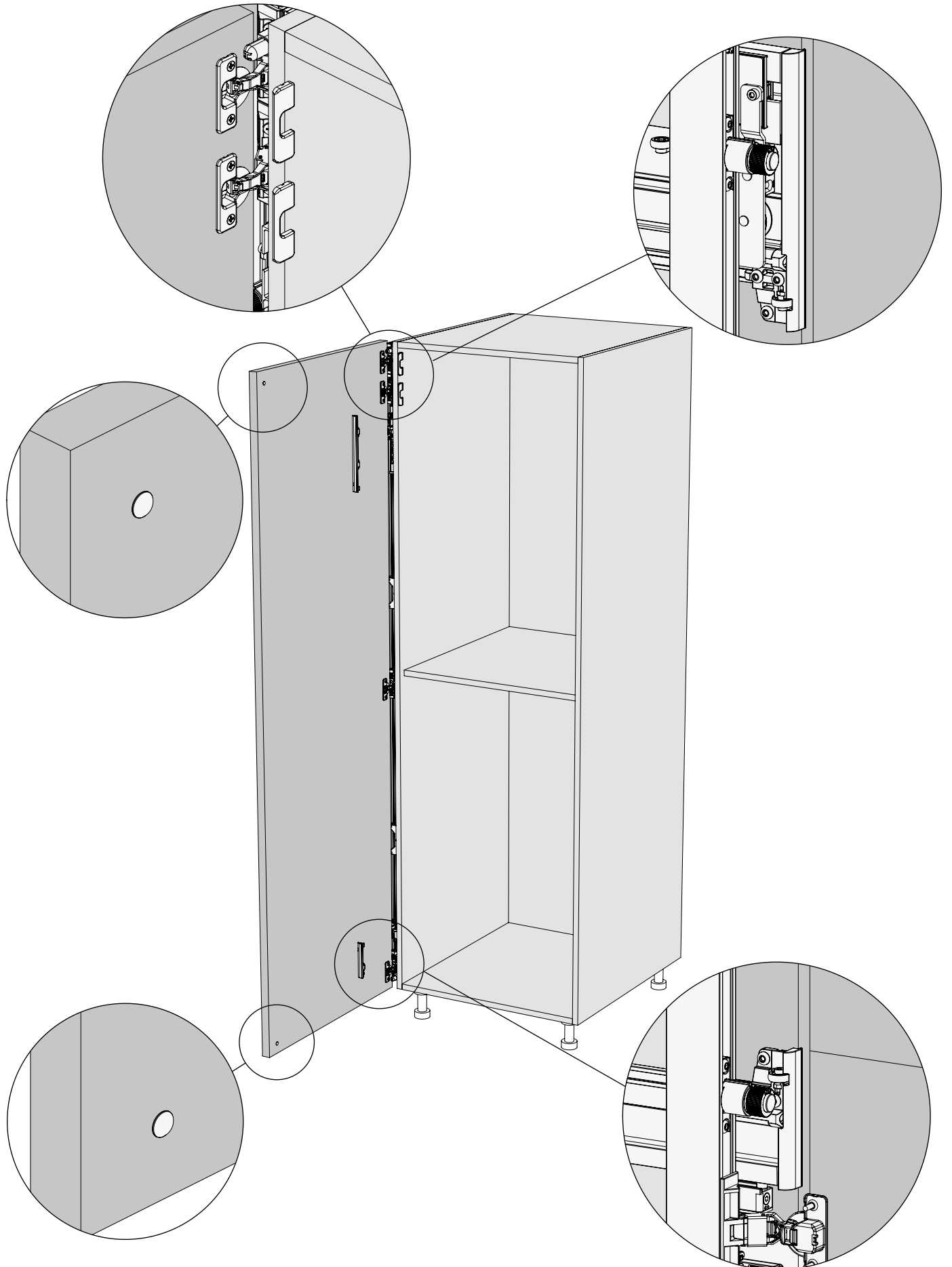

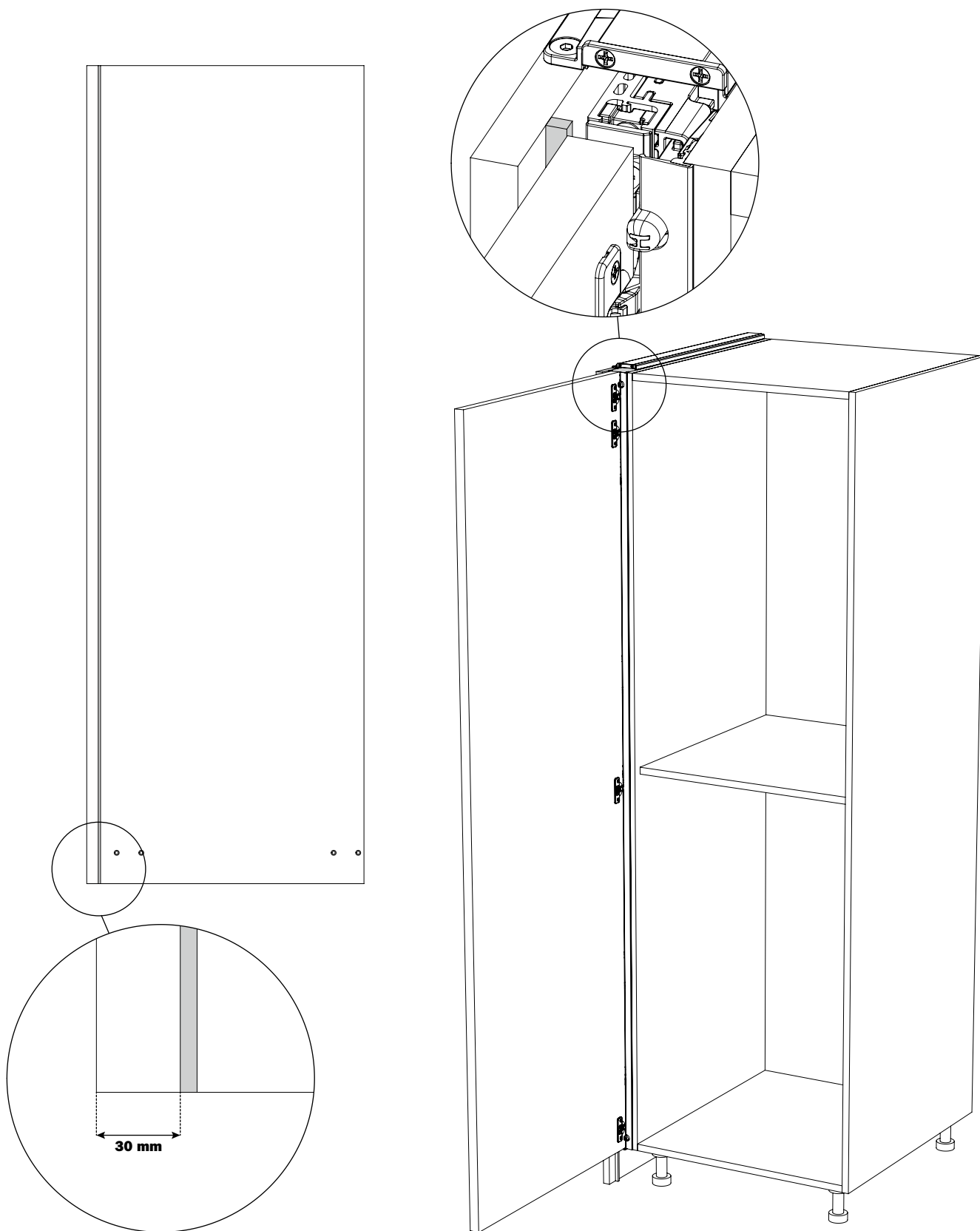

- 
- Accessori
  - Accessories
  - Zubehör
  - Accessoires
  - Acessório
  - Acessórios
  - 配件

[ITA] Giunzione fianco struttura

[ENG] Side panel connector kits

[ESP] Conexión del lateral a la estructura

[DEU] Verbindung Seitenwand des Möbels

[POR] junção lateral da estrutura

[FRA] Joint d'assemblage latEral du meuble

[ZH] 间距盖条套装

	Part number	PS (mm)			
			(kg)	(m <sup>3</sup> )	(mm)
	<b>VE55KIT0001</b>	400÷650	0,85	0,003	90 x 45 x 770
	<b>VE55KIT0002</b>	650÷900	1,0	0,004	90 x 45 x 1020
	<b>VE55KIT0005</b>	400÷650	0,85	0,003	90 x 45 x 770
	<b>VE55KIT0006</b>	650÷900	1,0	0,004	90 x 45 x 1020
	<b>VE55KIT0003</b>	400÷650	1,5	0,003	130 x 45 x 770
	<b>VE55KIT0004</b>	650÷900	1,8	0,004	130 x 45 x 1020



[ITA] **Kit copertura frontale**

[ENG] **Front cover strips**







[ESP] **Kit cobertura frontal**

[DEU] **Kit Frontabdeckung**

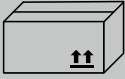
[POR] **Kit cobertura frontal**

[FRA] **Kit de cache frontal**

[ZH] 前挡尘条

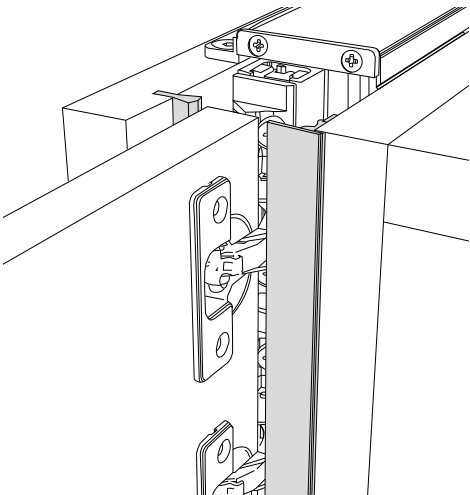
						Part number
						(m)
						<b>VE55KIT0201</b>
	2,6		0,7	0,03	100 x 100 x 2700	
	2,6		0,7	0,03	100 x 100 x 2700	
						<b>VE55KIT0203</b>
	2,6		0,7	0,03	100 x 100 x 2700	

[ITA] **Deceleratore smove**

[ENG] **Smove damper**







[ESP] **Amortiguador smove**

[DEU] **Smove Dämpfer**

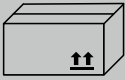
[POR] **Desacelerador smove**

[FRA] **Amortisseur smove**

[ZH] 闭门阻尼器

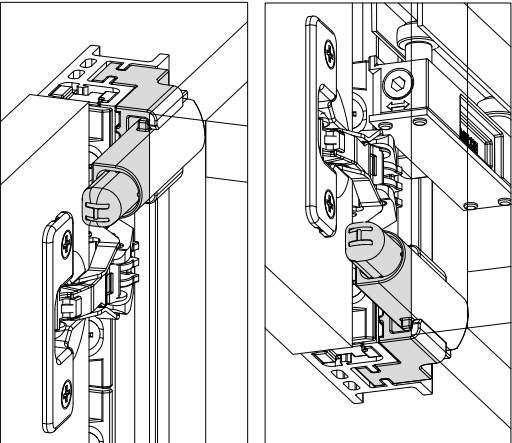
						Part number	pcs.
						<b>YE55KIT0050</b>	1
						Kit con 2 Smove per ante con 3 cerniere Kit with 2 Smove for doors with 3 hinges Kit mit 2 Smove für Türen mit 3 Scharnieren Kit avec 2 Smove pour portes avec 3 charnières Kit con 2 Smove para puertas con 3 bisagras Kit com 2 Smove para portas com 3 dobradiças 套装包含 2 个 Smove 阻尼, 用于 3 只铰链的门板	
						<b>YE55KIT0055</b>	1
						Kit con 2 Smove per ante con 4 e 5 cerniere Kit with 2 Smove for doors with 4 and 5 hinges Kit mit 2 Smove für Türen mit 4 und 5 Scharnieren Kit avec 2 Smove pour portes avec 4 et 5 charnières Kit con 2 Smove para puertas con 4 y 5 bisagras Kit com 2 Smove para portas com 4 e 5 dobradiças 套装包含 2 个 Smove 阻尼, 用于 4-5 只铰链的门板	

[ITA] Lavorazioni sul fianco

[ENG] Cover panel drillings

[ESP] Trabajos en el lateral

[DEU] Bearbeitungen der seite

[POR] Usinagens na lateral

[FRA] Opérations sur le côté

[ZH] 侧板孔位

VE55KIT0001 - 2 - 3 - 4 - 5 - 6

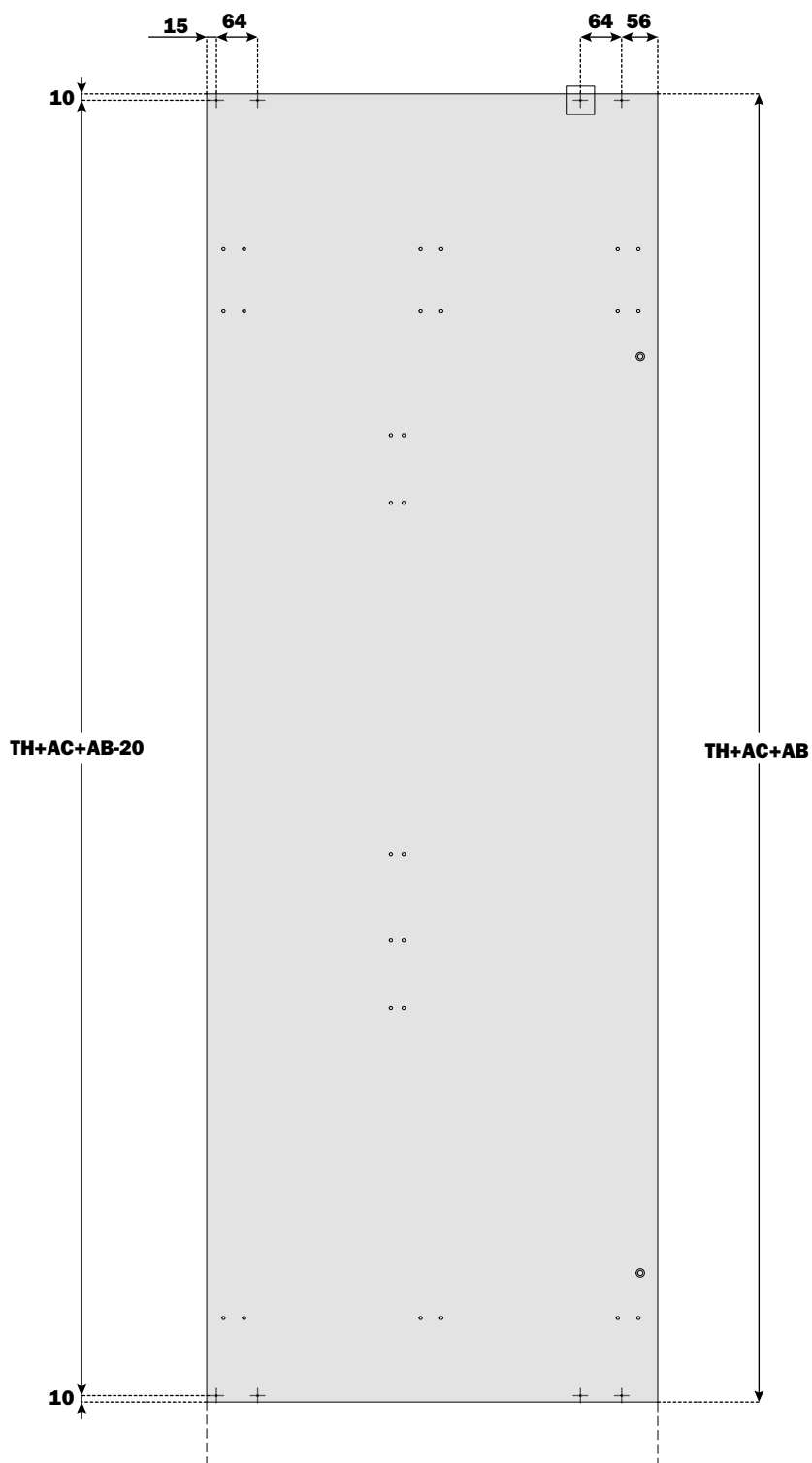
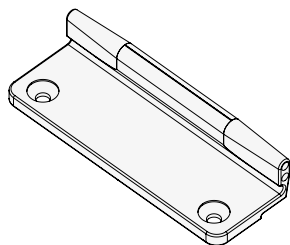
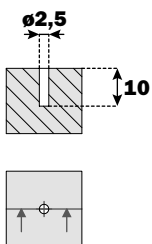



VE55KIT0201 - 2 - 3

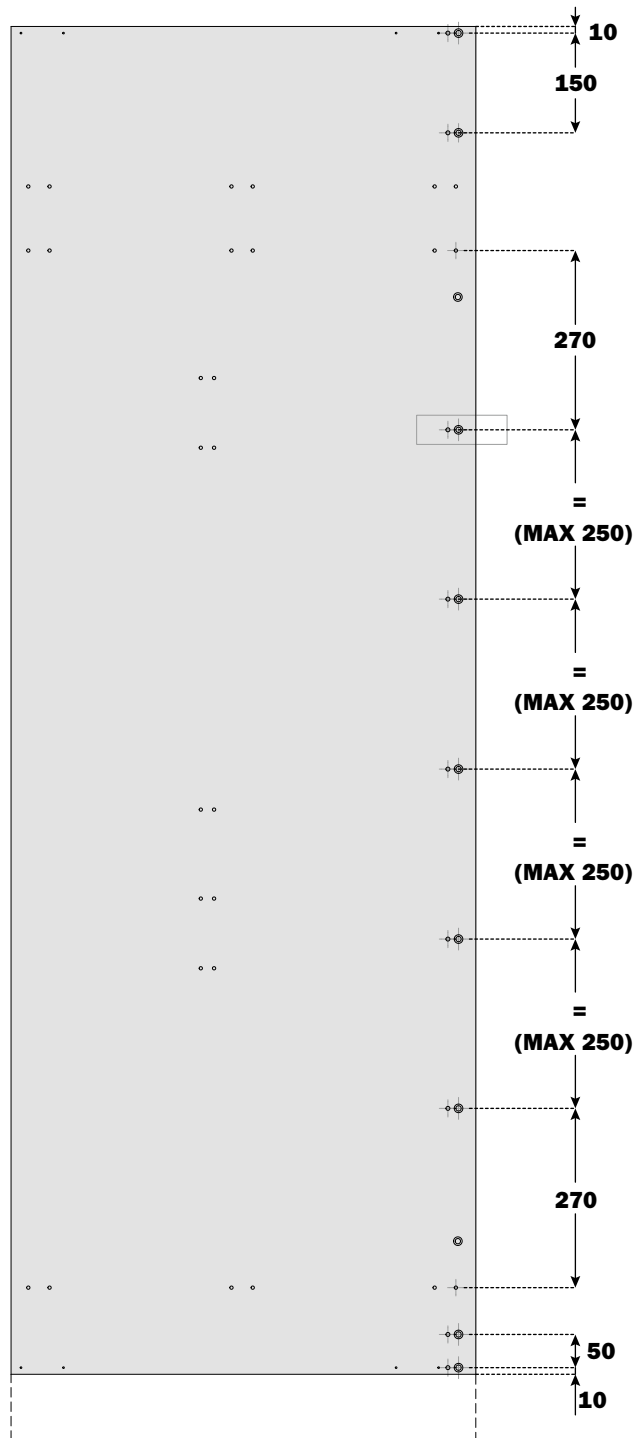
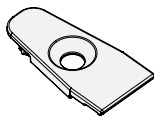
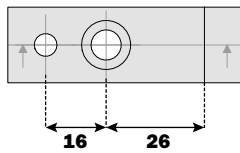
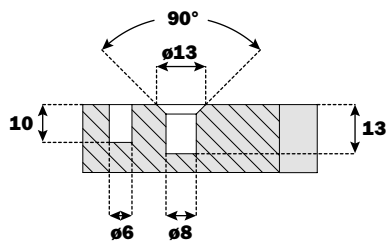

[ITA] Lavorazioni sul fianco di copertura

[ENG] Workings on the side cover

[ESP] Mecanizados en el lateral de cobertura

[DEU] Bearbeitungen der Abdeckseite

[POR] Usinagens na lateral de cobertura

[FRA] Opérations sur le panneau de recouvrement

[ZH] 外封板孔位、加工

VE55KIT0001 - 2

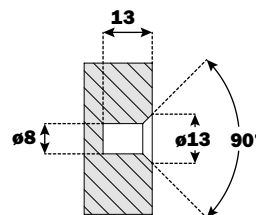
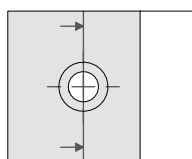
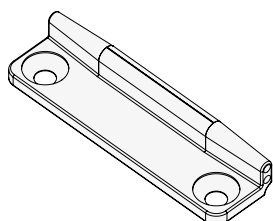
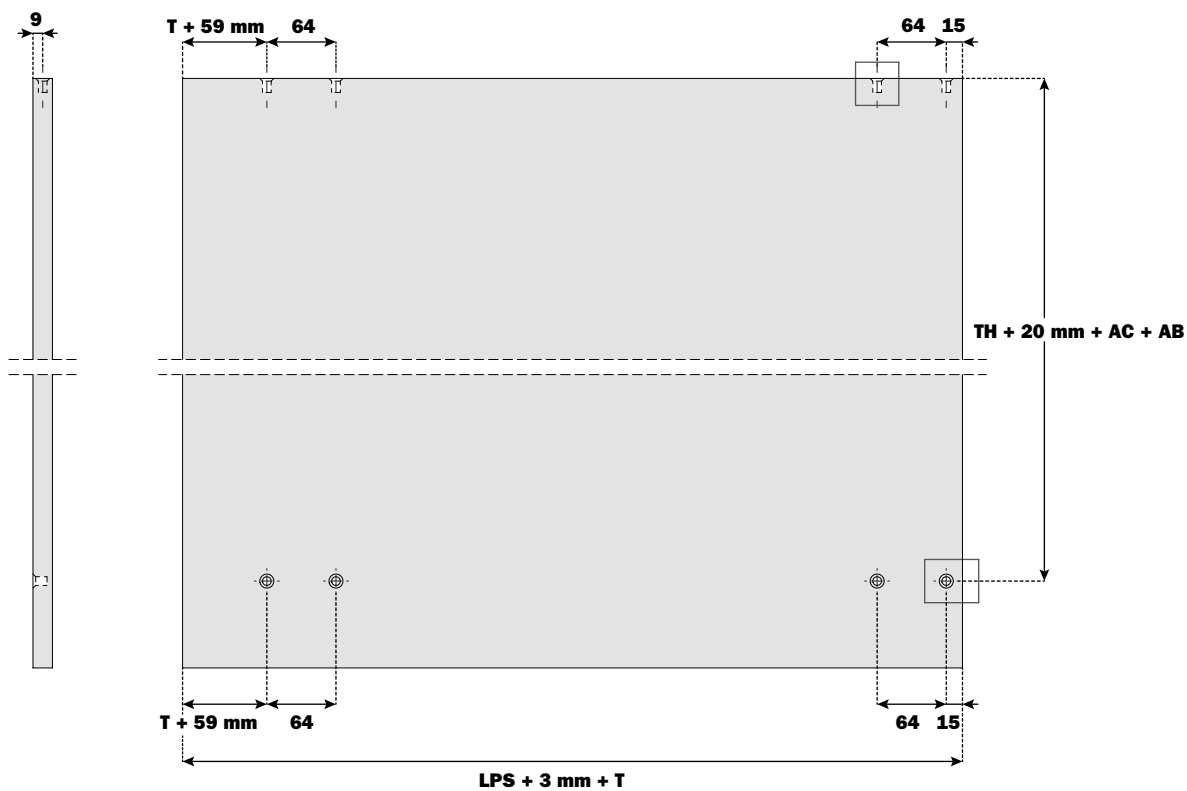
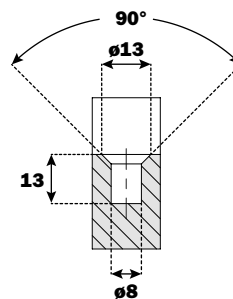
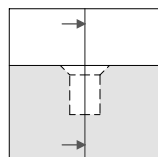
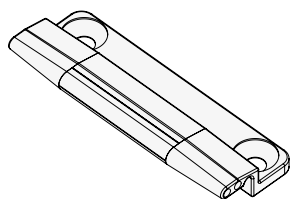



VE55KIT0003 - 4 - 5 - 6

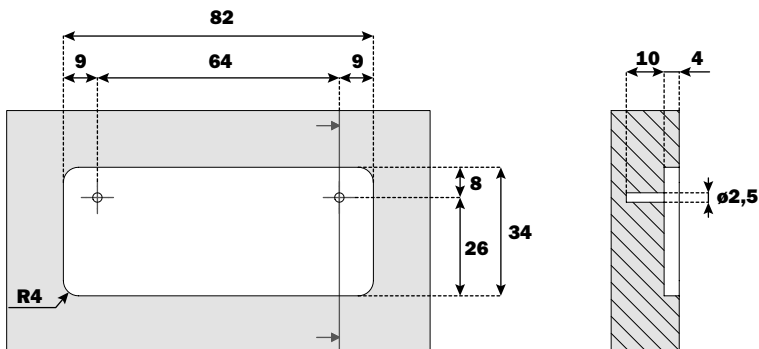
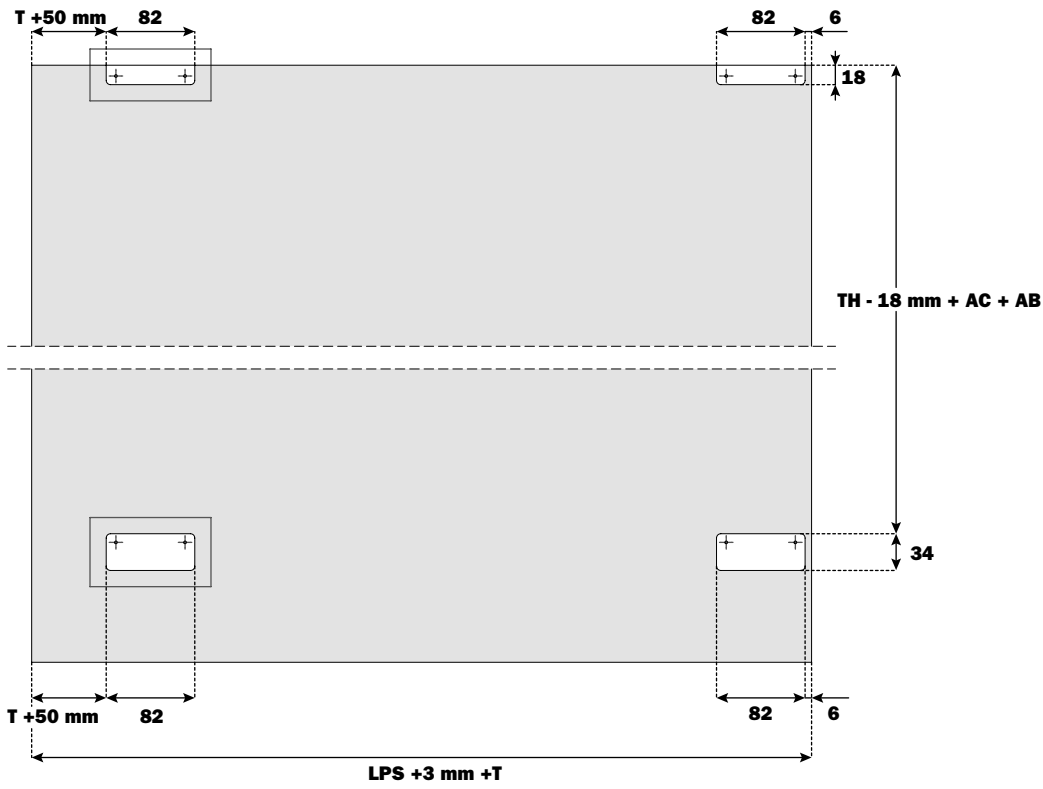
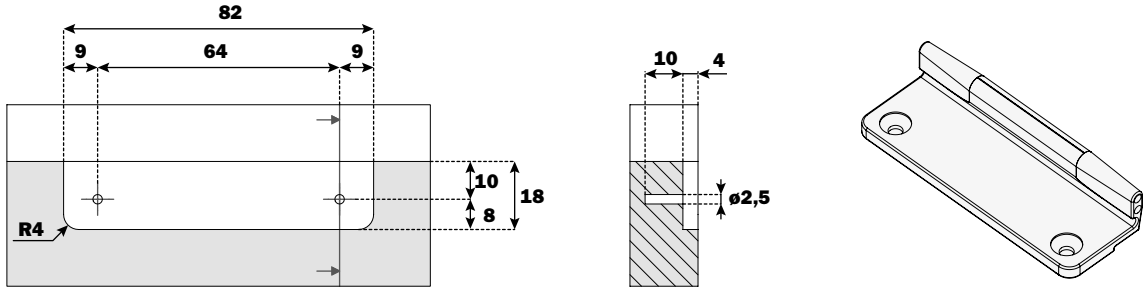

[ITA] Montaggio collegamenti sul fianco

[ENG] Fitting the brackets to the side panel

[ESP] Montaje de las conexiones en el lateral

[DEU] Montage der Verbindungen an der Seite

[POR] Montagem dos conectores na lateral

[FRA] Montage des joints d'assemblage latéraux sur le côté

[ZH] 安装间距盖条

VE55KIT0001 - 2 - 3 - 4 - 5 - 6

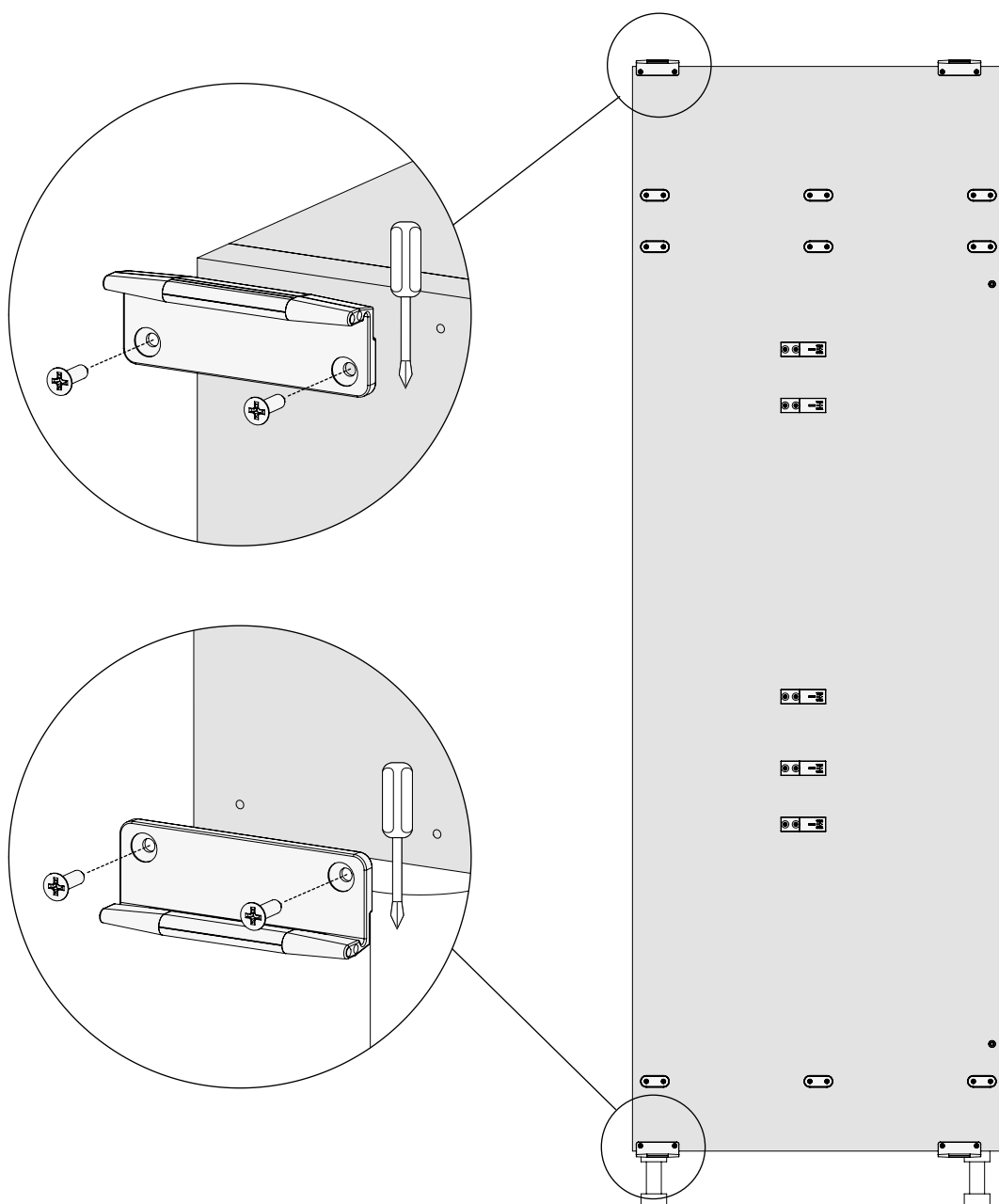



VE55KIT0001 - 2

VE55KIT0201 - 2 - 3

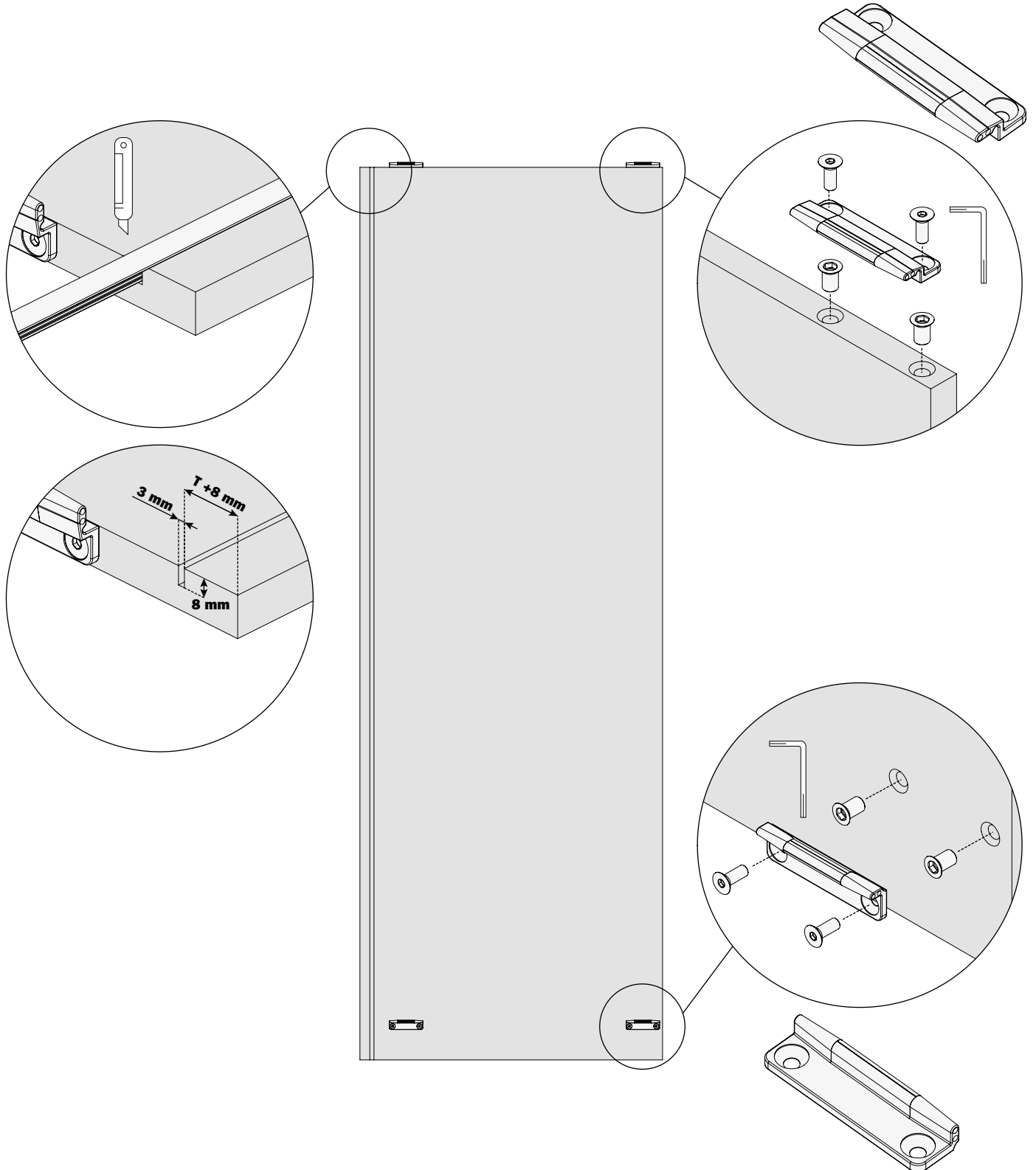

VE55KIT005 - 6

VE55KIT0201 - 2 - 3

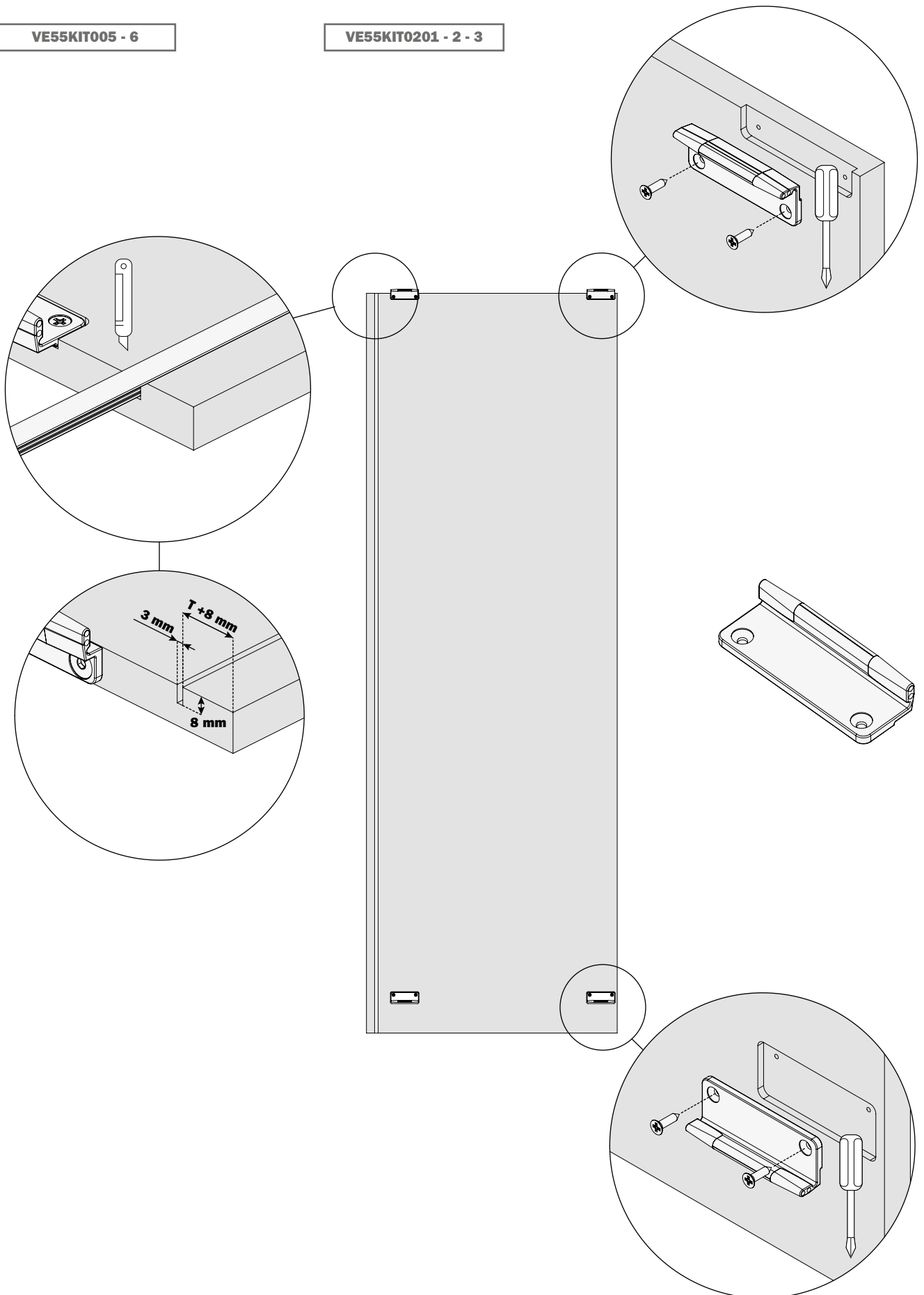



VE55KIT0001 - 2 - 5 - 6

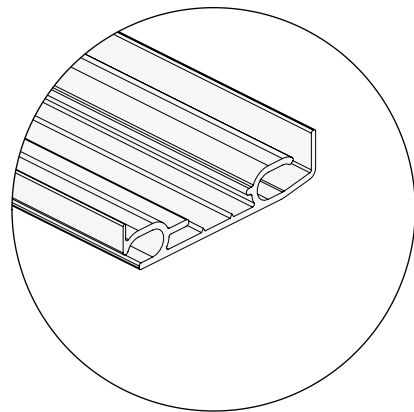
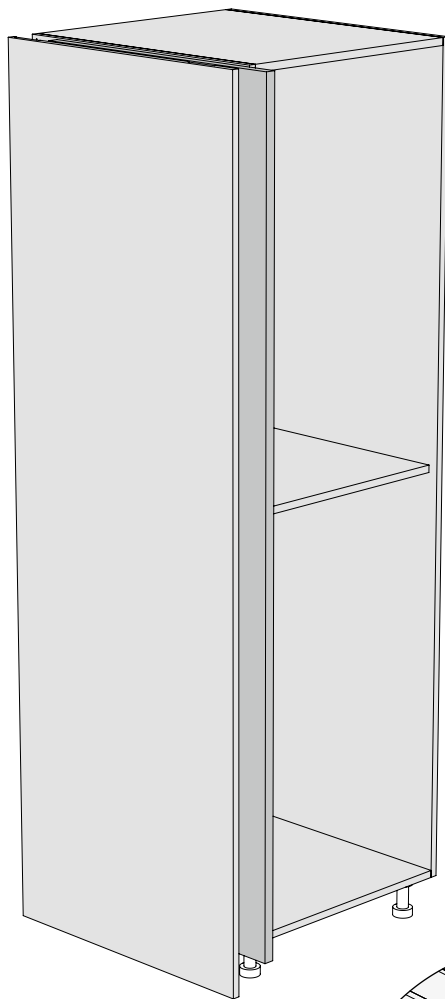
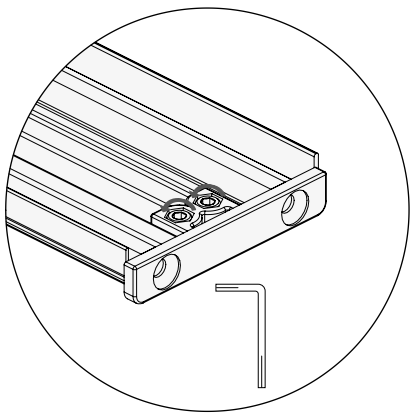
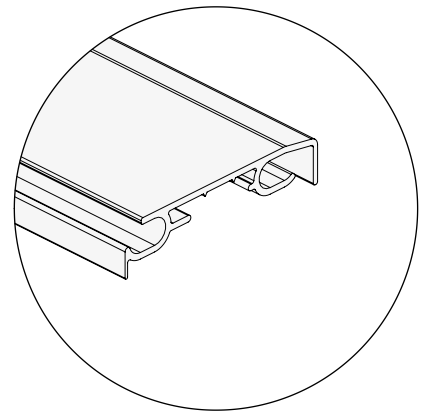
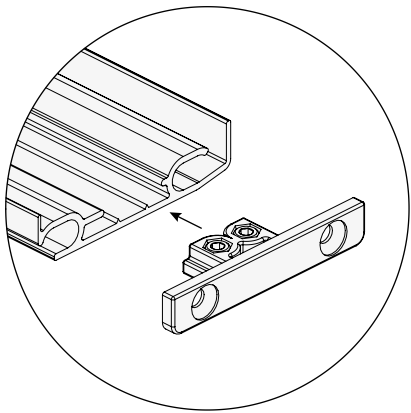
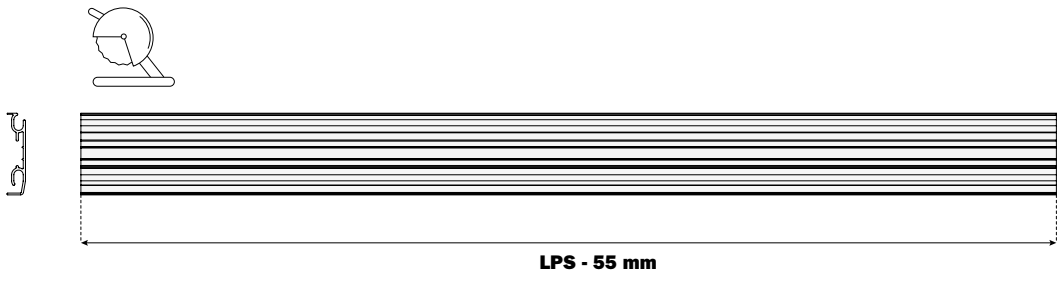

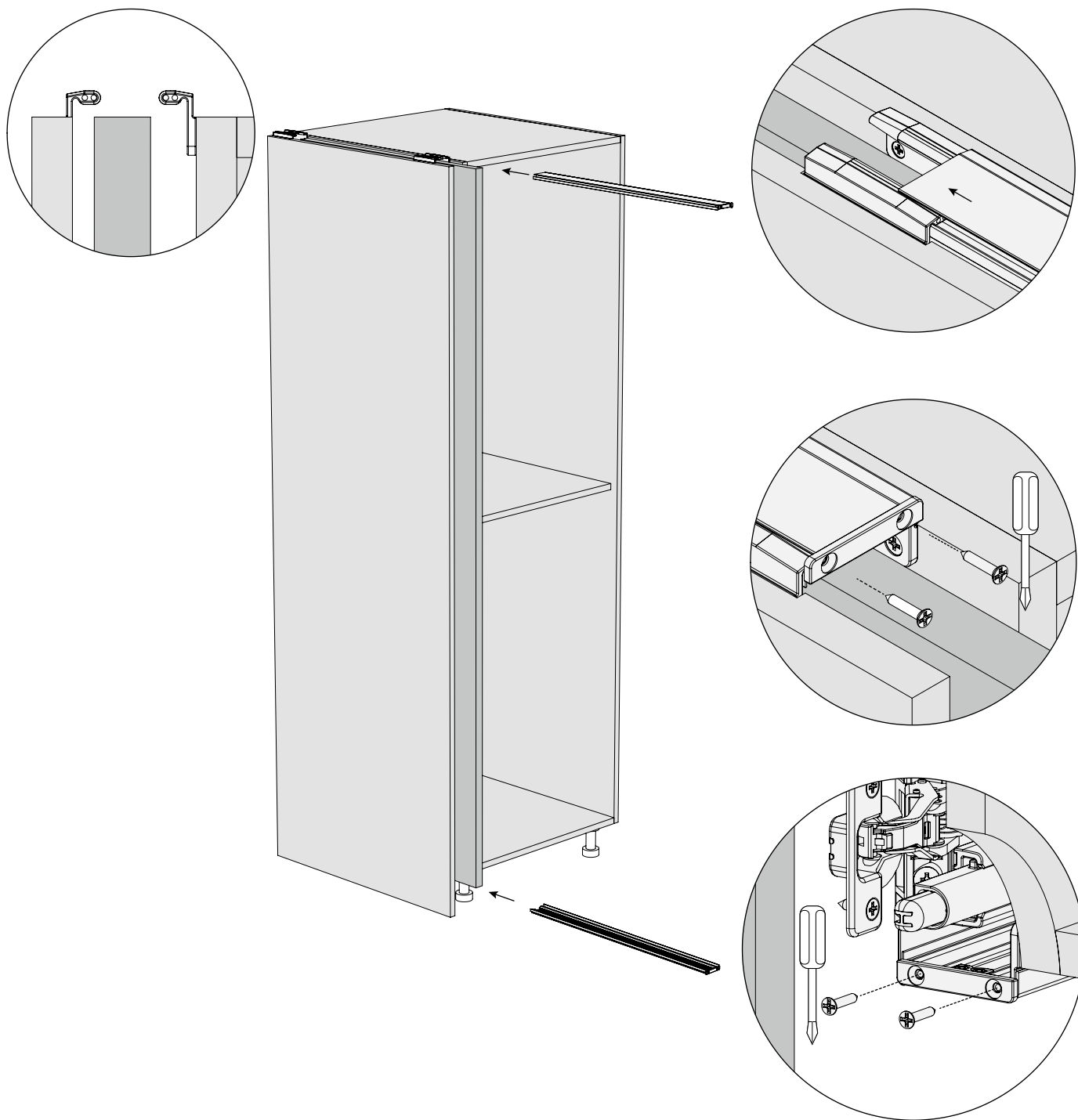





[ITA] Applicazione del profilo di copertura

[ENG] Fitting the cover strips

[ESP] Aplicación del perfil de cobertura

[DEU] Befestigung des Abdeckprofils

[POR] Aplicação do perfil de cobertura

[FRA] Installation du profile de recouvrement

[ZH] 安装前挡尘条

VE55KIT0201 - 2 - 3

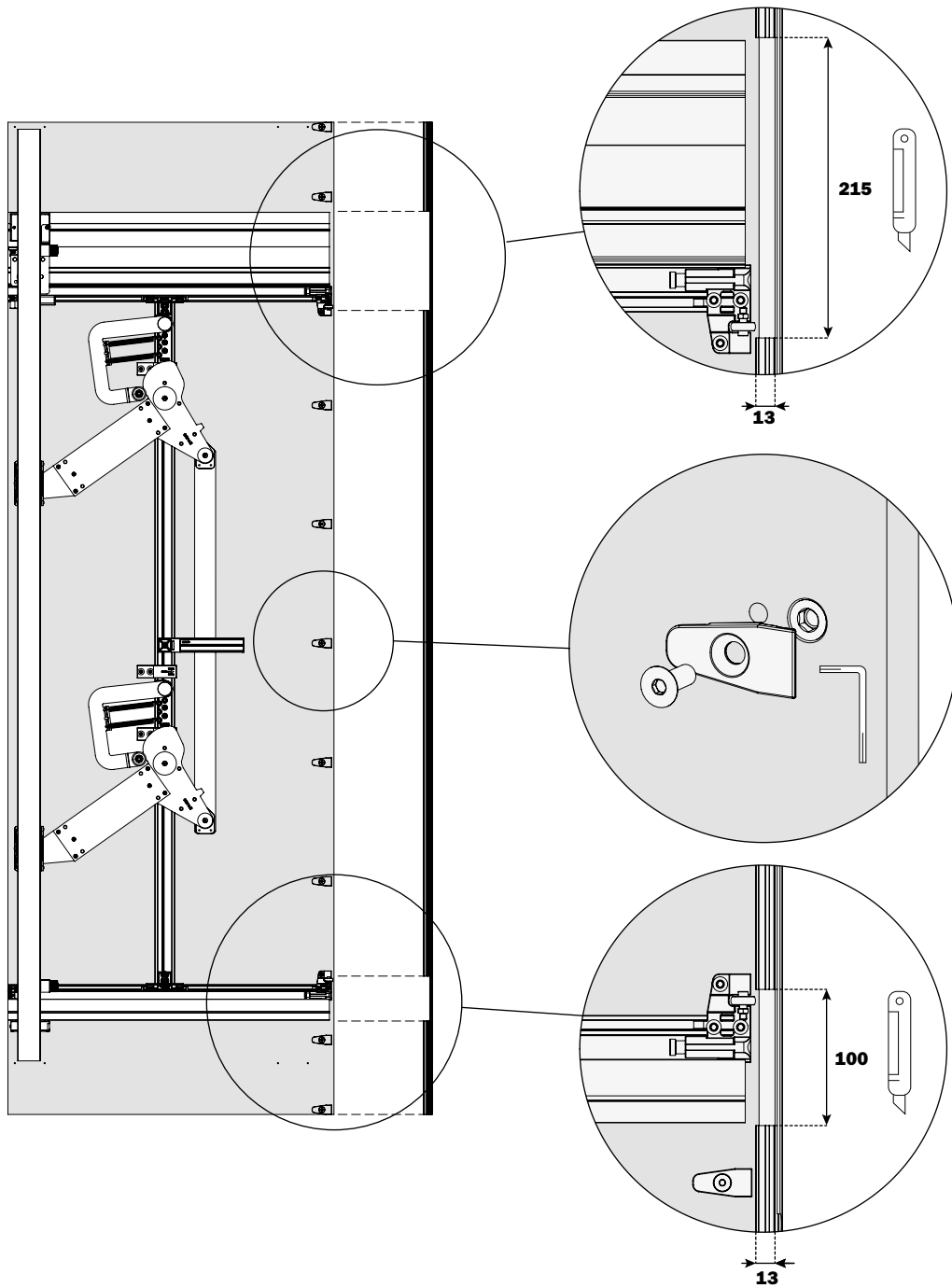



VE55KIT0003 - 4

LPS - 55 mm

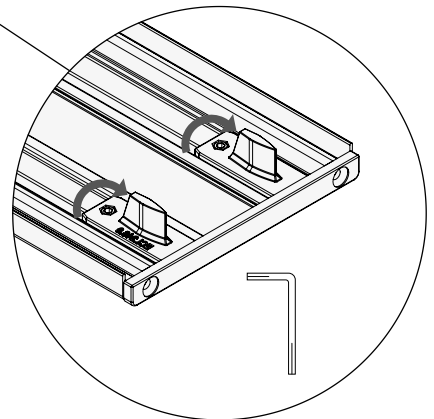
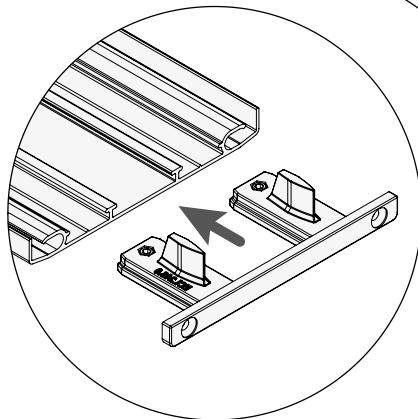
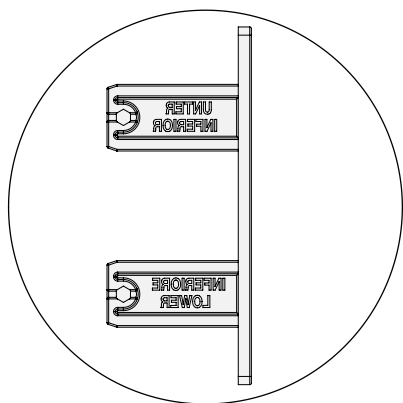
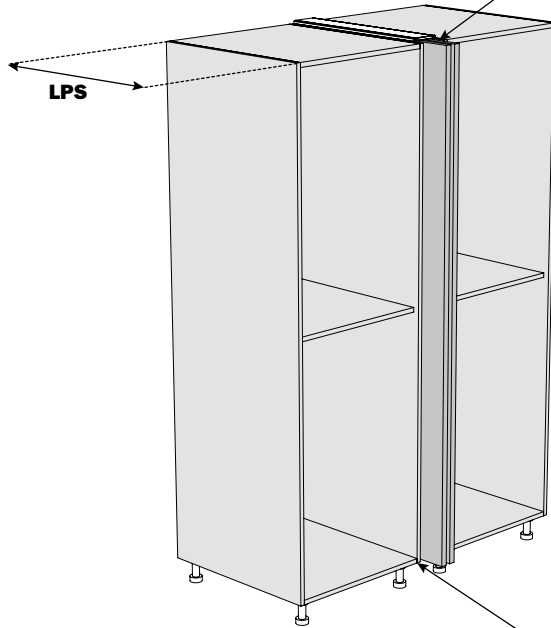
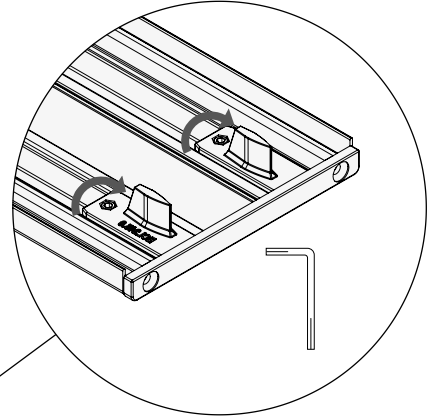
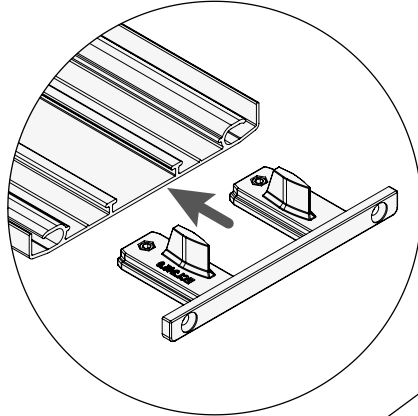
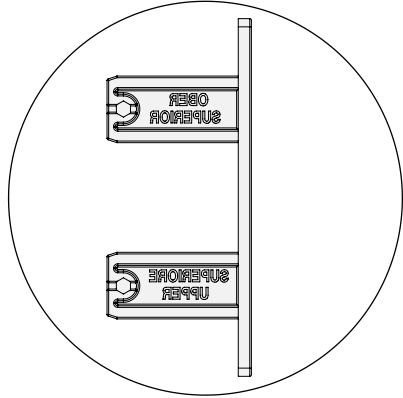
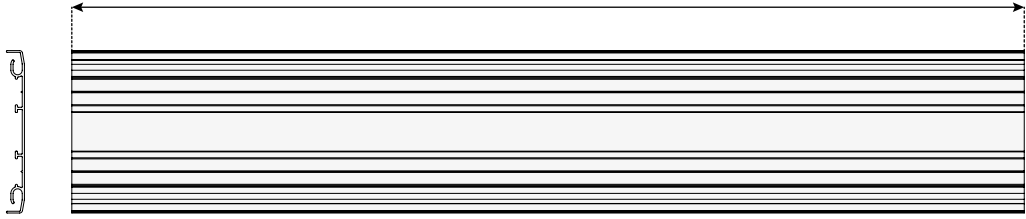

- 
- Rimozione del meccanismo dal mobile
  - Removal of the mechanism from the cabinet
  - Demontage des Mechanismus aus dem Möbel
  - Démontage du mécanisme du meuble
  - Extracción del mecanismo del mueble
  - Remoção do mecanismo do móvel
  - 系统机构从柜体拆卸

