

Dispensa TANDEM

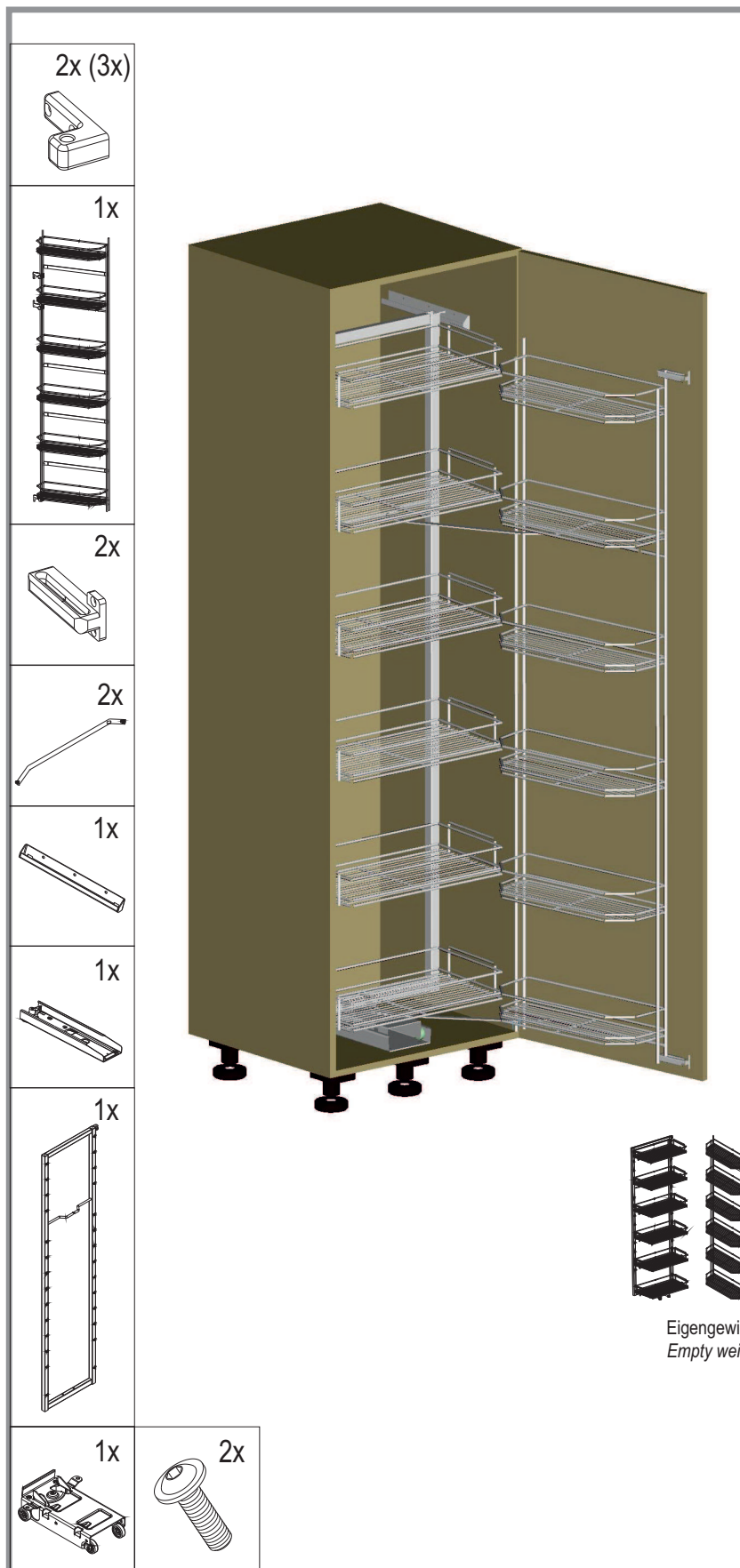

KESSEBÖHMER



Montageanleitung

Dispensa TANDEM Schwenkauszug für 60er Hochschrank

Mounting Instructions

for 600 mm
Dispensa TANDEM swivel pull-out

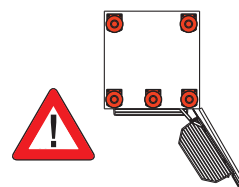
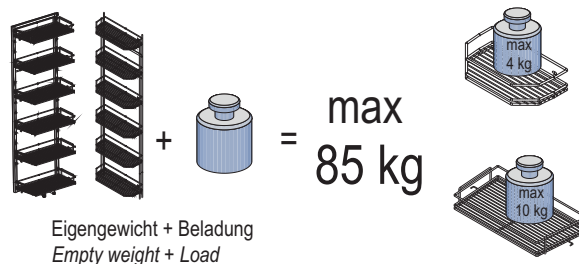

Dispensa TANDEM



KESSEBÖHMER

SYMBOLE • SYMBOLS • SYMBOLES • SYMBOLI • SIMBOLOS • SIMBOLOS • MERKIT • SYMBOLER • SYMBOLY • SYMBOLE •



Warnung! • Warning! • Avertissement! • Avvertenza! • ¡Advertencia! • Aviso! • Varoitus! • Advarsel! • Výstraha! • Ostrzezenie! •



Nicht korrekt! • Incorrect! • Incorrect! • Non corretto! • ¡Incorrecto! • Incorrecto! • Väärin! • Ikke korrekt! • Nesprávně! • Nieprawidłowo!



Korrekt! • Correct! • Correct! • corretto! • ¡Correcto! • Correcto! • Oikein! • Korrekt! • Správně! • Prawidłowo!!



Fixieren/fixiert! • Secure/Secured! • Fixer/fixé • Fissare/fissato! • ¡Fijar/fijado! • Fixar/fixo! • Kiinnitä/kiinnitetty! • Spænde/sændt •



Lösen/gelöst! • Release/Released! • Détacher/détaché • Allentare/allentato! • ¡Soltar/suelto! • Soltar/solto! • Irroita/irroitettu! • Lösne/løsnet • Povolit/povolento! • Zwolnic/zwolnione!



Keinen Akkuschauber verwenden! • Do not use a cordless screwdriver! • Ne pas utiliser de tournevis à piles • Non utilizzare un avvitatore a batteria! • ¡No utilizar tladro atornillador! • Não usar aparafusadora sem fio! • ÄLÄ käyttää akkuruvinväännintä! • Brug ikke batteriskruetrækker! • Nepouzivejte akušroubovák! • Nie używac wkrtarki akumulatorowej! •



PZ2-Schraubendreher verwenden! • Use a PZ2 screwdriver! • Utiliser un tournevis Pz2 • Usare il cacciavite Pz2! • ¡Utilizar un destornillador Pz2! • Usar chave de parafusos Pz2! • Käytä PZ2-ruuviataltaa! • Brug PZ2-skrueetrækker! • Pouzijte krizový šroubovák Pz2! • Użyc wkretaka Pz2!



Optionales Element! • Optional element! • Élément optionnel! • Elemento opzionale! • ¡Elemento opcional! • Elemento opcional! • Valinnainen elementti! • Valgfrit element! • Voltitelný prvek! • Element opcjonalny! •



Klick-Geräusch beim Einrasten! • Audible click on engagement! • <<Clic>> lors de l'encliquetage • Quando si innesta si sente un clic! • ¡Ciaondo encaja se oye un clic! • Ruído de clique ao engatar! • Lukittuessa kuuluu klik-ääni! • Klikyd ved monterging! • Slyšitelné zacvaknutí! • Trzask przy zaskakiwaniu! •



Alle Maße in mm! • All dimensions in mm! • Toutes les dimensions en mm! • Tutte le dimensioni in mm! • ¡Todas las medidas son en mm! • Todas as medidas em mm! • Kaikki mitat mm! • Alle mal er mm! • Vsechny rozmery v mm! • Wszystkie wymiary w mm! •

Die technische Darstellung und Maßangaben -auch bei Abbildungen und Zeichnungen - sind unverbindlich. Konstruktionsverbesserungen sind vorbehalten! • Technical information and stated dimensions (including in illustrations and drawings) must not be regarded as binding. Design subject to change without notice (in interest of improvement)! • Les illustrations technique et les cotes y compris sur les schémas et les dessins sont non contractuelles. Sous réserve d'améliorations de la construction! • Le rappresentazioni tecniche e le indicazioni delle dimensioni anche nelle figure e nei disegni non sono vincolanti. Con riserva di miglioramenti di progettazione! • Las descripciones técnicas y los datos dimensionales, inclusive los incluidos en fotos y figuras, son meramente orientativos y no vinculantes. ¡Reservado el derecho a mejoras constructivas! • As descrições técnicas e as indicações de medidas também em ilustrações e desenhos não são de natureza imperativa. Salvo melhoramentos de construção! • Tekniset piirroksset ja mitat myös kuvissa ja piirroksissa olevat ovat sitoumuksetta. Oikeus teknisiin parannuksiin pidätetään! • De tekniske fremstillinger og måleangivelser også i figurer og tegninger er vejledende. Forbehold for konstruktionsforbedringer! • Technické znázornění a rozměry i na obrázcích a výkresech jsou nezávazné. Konstrukční změny vyhrazeny! • Prezentacje techniczne i dane wymiarowe także na rysunkach są niewiązace. Zmiany konstrukcyjne zastrzeżone! •

Dispensa TANDEM



KESSEBÖHMER

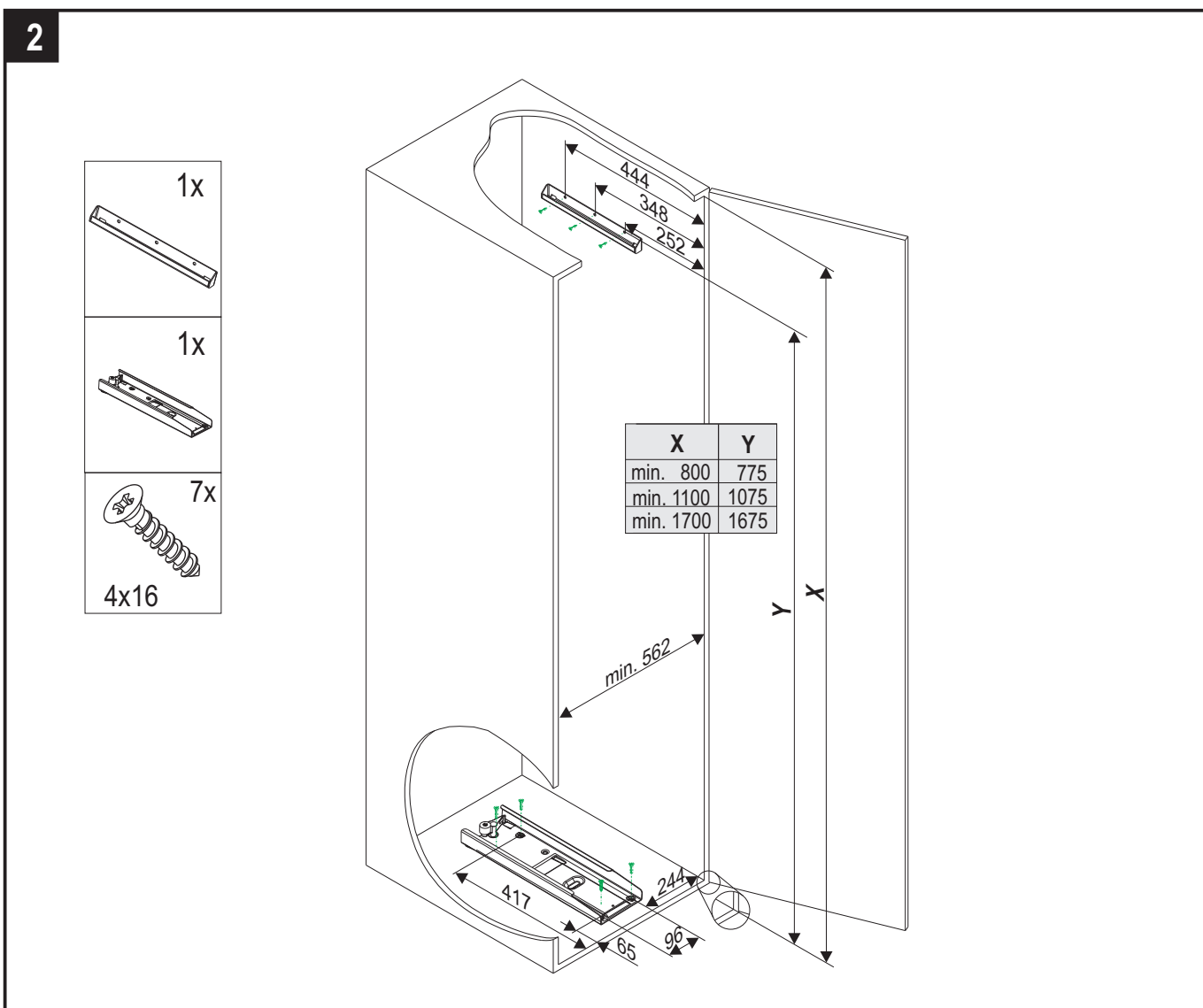
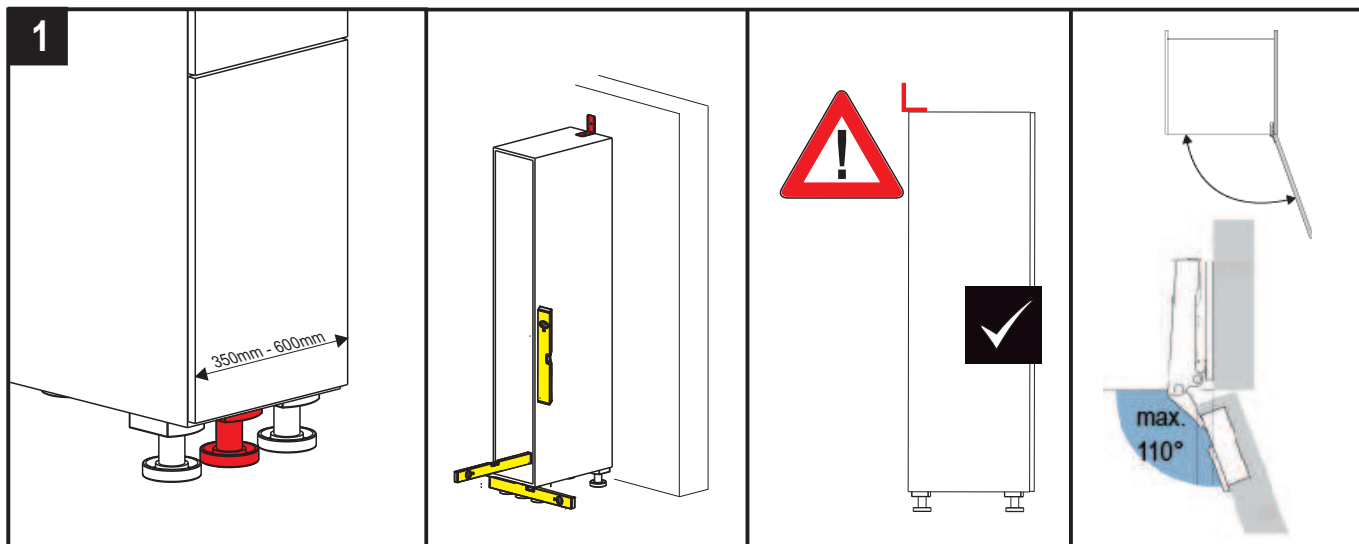

Dispensa TANDEM



KESSEBÖHMER

3 Tür rechts
Door right

2x (3x)
4x(6x)
4x20

optional

Sollte auf Höhe der oberen Lager ein Türscharnier montiert sein, so ist das betroffene Lager entsprechend tiefer zu montieren
In case of top bearings are in same height as hinge, the bearing is to move to the next possible lower position

X	Y	Z
min. 800	625	-
min. 1100	625	815
min. 1700	1225	1415

4 Tür links
Door left

2x (3x)
4x(6x)
4x20

optional

X	Y	Z
min. 800	625	-
min. 1100	625	815
min. 1700	1225	1415

Sollte auf Höhe der oberen Lager ein Türscharnier montiert sein, so ist das betroffene Lager entsprechend tiefer zu montieren
In case of top bearings are in same height as hinge, the bearing is to move to the next possible lower position

5

1x
1x
2x

6

1.
2.
3.

6.1

6.2

Dispensa TANDEM



KESSEBÖHMER

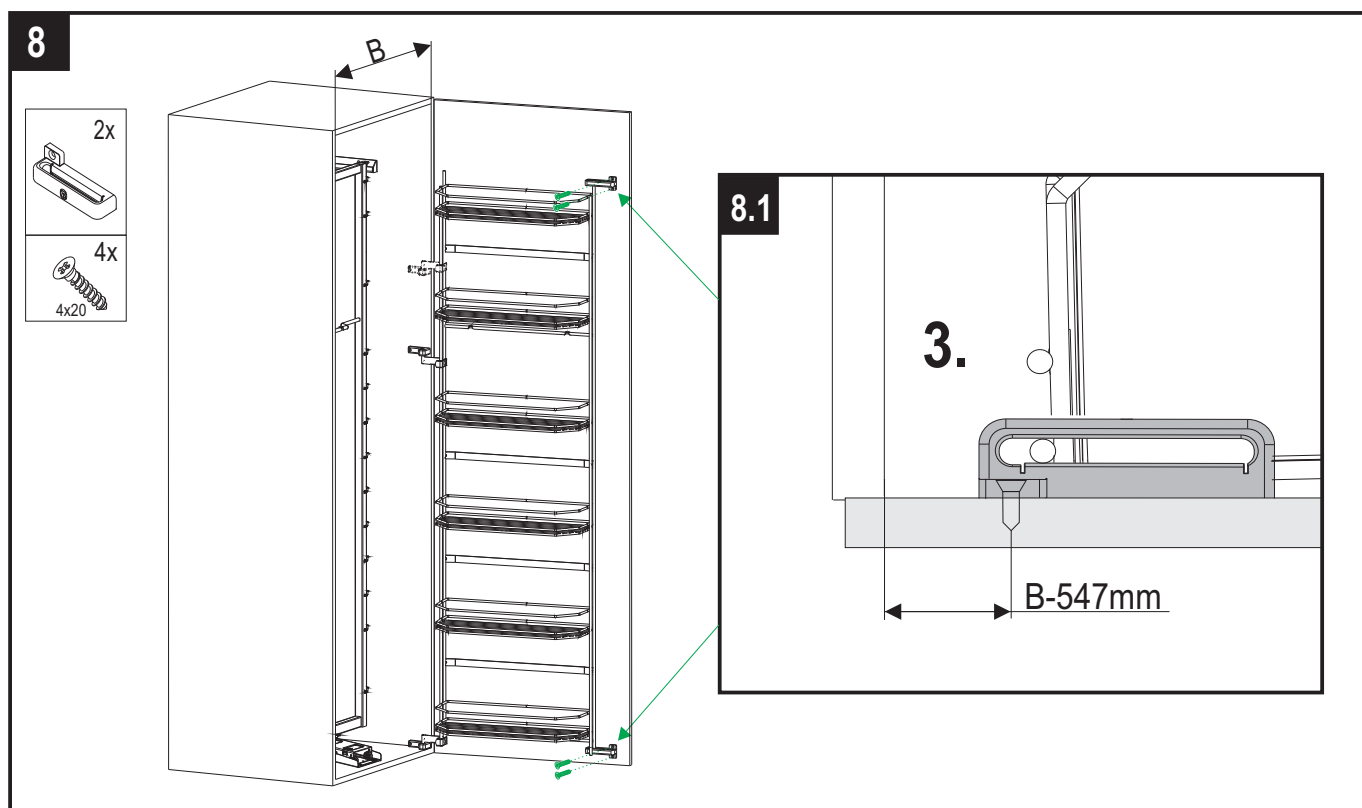
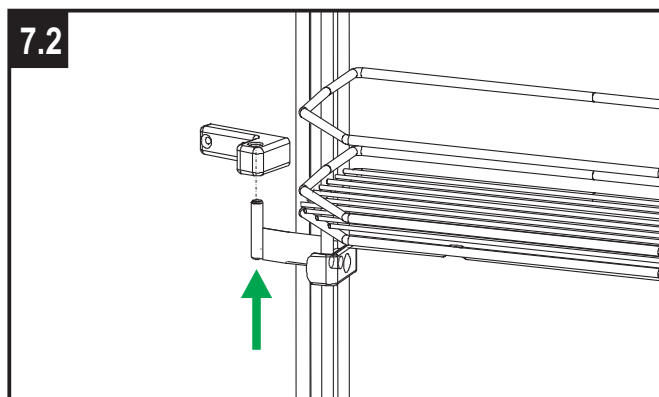
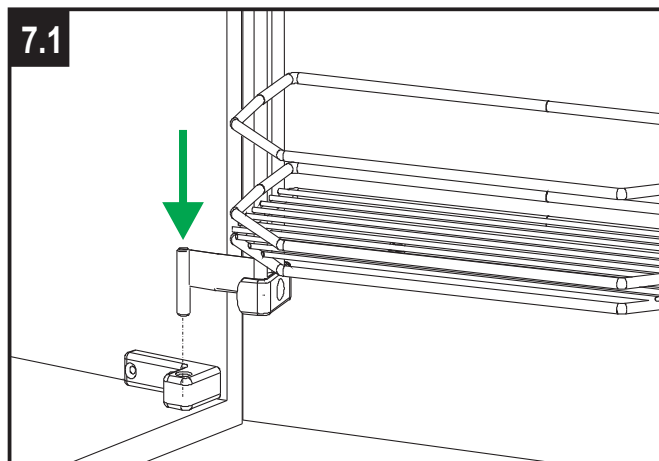
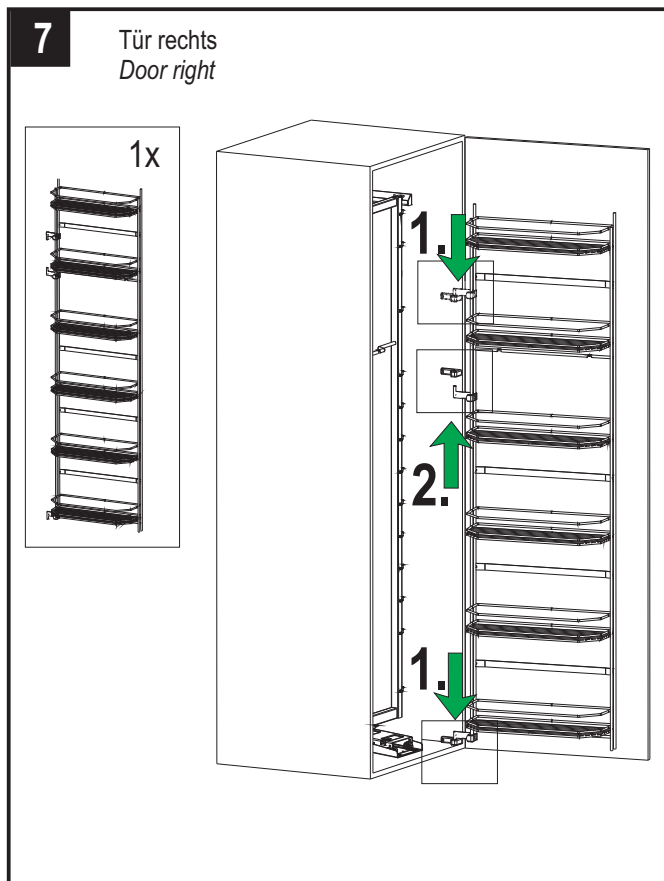

Dispensa TANDEM



KESSEBÖHMER

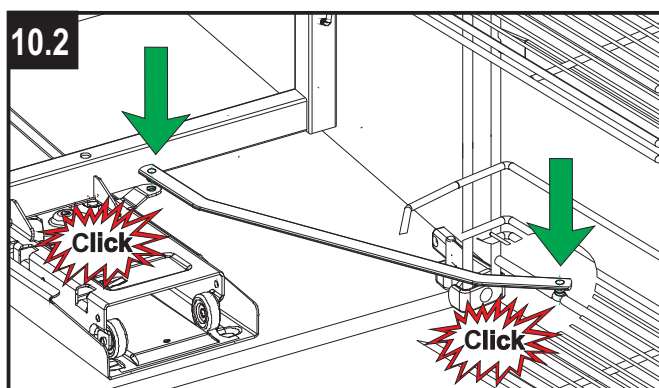
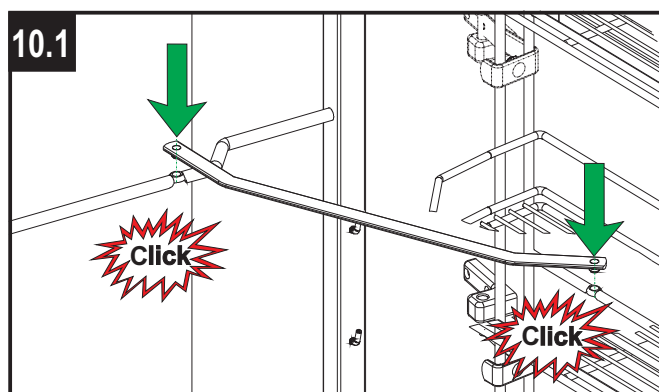
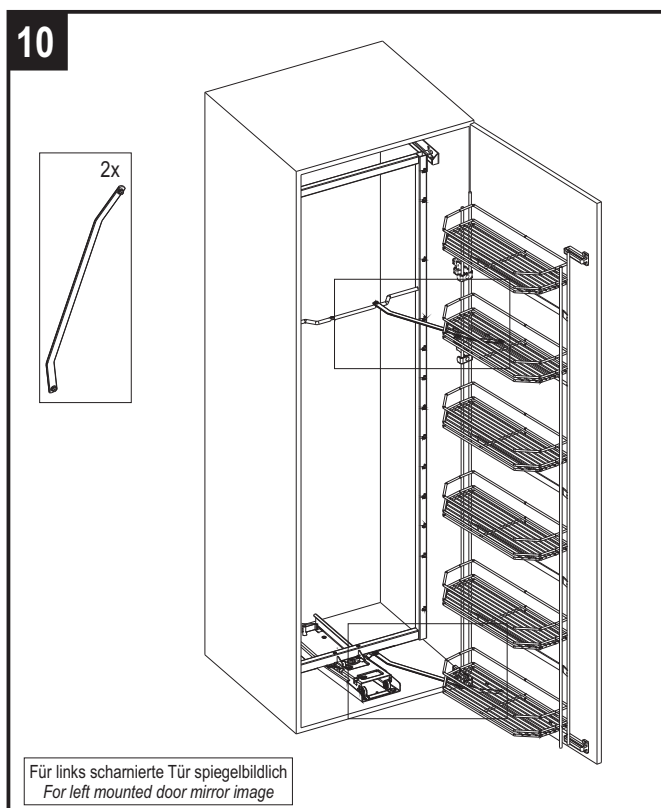
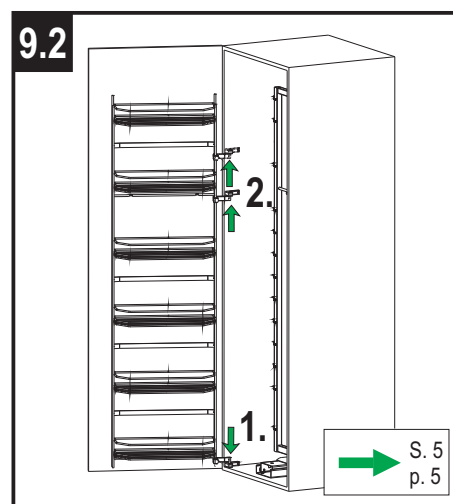
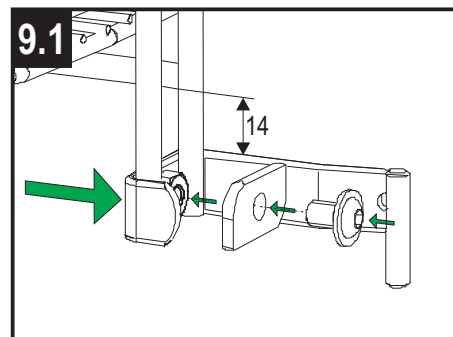
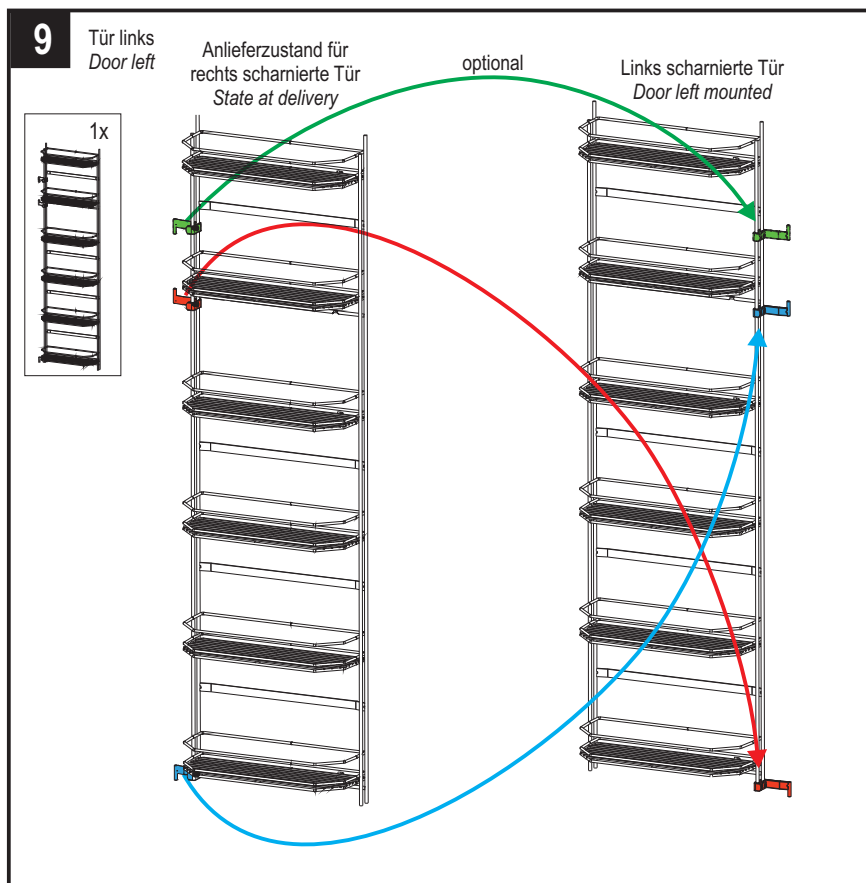







Dispensa TANDEM

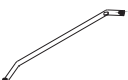
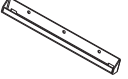

KESSEBÖHMER

Aufbau als TANDEM Depot
Installation as Chef's Pantry

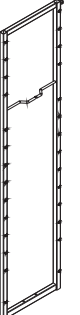
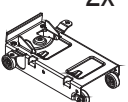
<p>4x (6x)</p> 	
<p>2x</p> 	
<p>4x</p> 	
<p>4x</p> 	
<p>2x</p> 	
<p>2x</p> 	
<p>2x</p> 	
<p>2x</p> 	

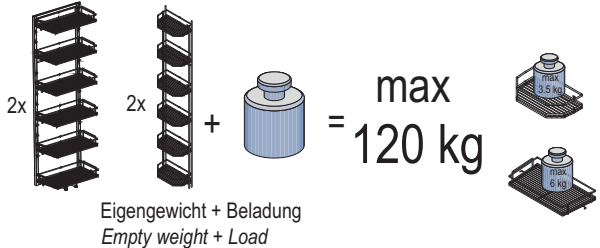

2x 2x + = max 120 kg

Eigengewicht + Beladung
 Empty weight + Load

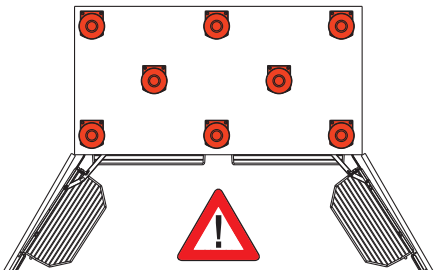

Dispensa TANDEM



KESSEBÖHMER

